

# REPORT

Sjø 2010/04



THE JOINT ACCIDENT INVESTIGATION BOARD NORWAY &  
BAHAMAS MARITIME AUTHORITY MARINE ACCIDENT REPORT

CRETE CEMENT - IMO NO. 9037161, GROUNDING  
AT ASPOND ISLAND IN THE OSLO FJORD,  
NORWAY, ON 19 NOVEMBER 2008



## TABLE OF CONTENTS

NOTIFICATION OF THE ACCIDENT.....	3
SUMMARY .....	3
1. FACTUAL INFORMATION .....	5
1.1 Details about the vessel.....	5
1.3 Weather and astronomical data.....	6
1.4 Course of events leading up to the grounding .....	6
1.5 The rescue action .....	8
1.6 Damage to the vessel and ingress of water .....	9
1.7 Oil-spill response following the grounding .....	13
1.8 The shipping company.....	15
1.9 The owner and vessels' safety management system.....	16
1.10 Crete Cement .....	17
1.11 The Crete Cement's crew .....	24
1.12 Charts .....	24
1.13 Operation of the loading/discharge system.....	26
1.14 Watertight integrity of the Crete Cement on running aground.....	27
1.15 Rescue actions in Norway.....	28
1.16 Emergency preparedness against acute pollution .....	28
1.17 Pilotage services .....	30
1.18 Navigational aids and chart corrections.....	33
1.19 Horten VTS.....	35
1.20 Other information .....	36
2. ANALYSIS .....	38
2.1 Introduction.....	38
2.2 Bridge resource management.....	38
2.3 Sleepiness.....	40
2.4 Charts and navigation .....	42
2.5 Steering the vessel .....	44
2.6 Watertight integrity.....	44
2.7 Beaching .....	45
3. CONCLUSIONS .....	46
3.1 Contributory factors and barriers.....	46
3.2 Factors with a bearing on the consequences of the grounding .....	46
3.3 Factors with a bearing on the actions following the grounding.....	47
3.4 Actions taken .....	47
4. SAFETY RECOMMENDATIONS .....	48
ANNEXES .....	50

## NOTIFICATION OF THE ACCIDENT

The Accident Investigation Board Norway (AIBN) was notified of a marine accident by the Joint Rescue Coordination Centre for South Norway (RCC-S) on 19 November 2008 at 07.00. It was reported that the Bahamas-registered cargo vessel *Crete Cement* had run aground off Aspond Island in the Oslofjord. The vessel took in water and had been beached off Fagerstrand. There were 13 people on board and the ship was carrying cement. At 08.32, the AIBN was notified that the vessel had been evacuated. Contact was established with the Bahamas Maritime Authority (BMA), and it was agreed that a joint investigation would be carried out in accordance with the IMO Code for the Investigation of Marine Casualties and Incidents. THE AIBN responded by sending four marine accident inspectors to Fagerstrand. Later that day, a representative of BMA arrived to participate in the investigation.



## SUMMARY

In the early morning of 19 November 2008, the *Crete Cement* was heading for Slemmestad, after having taken on board approximately 5,000 tonnes of cement at Norcem Brevik. There were 13 crew on board, including a pilot. The bridge was manned by the pilot, the officer of the watch and a lookout. On passing Digerud, the course should have been altered to starboard to pass between Digerud and Aspond Island. This was not done, and the *Crete Cement* ran aground at the south-eastern tip of Aspond Island at 06.31. It was initially decided to continue towards Slemmestad. This was soon reconsidered as it was discovered that *Crete Cement* was taking in a lot of water and large parts of the vessel was about to be flooded as a result of open or leaking hatches and manhole covers. It was decided to beach the vessel in the Grisebubukta bay off Fagerstrand instead. *Crete Cement* was beached at approximately 06.59. The vessel continued to take in water, and RCC decided to evacuate the crew to ensure their safety. Evacuation was completed at 08.30 without any personal injuries. Oil-spill response resources were soon in place, and the environmental consequences of the incident were minimal.

Several causes contribute to explaining why the course was not altered when passing Digerud. The pilot had been on duty for a week and, during this period, his work load had been heavy and involved much night work and few opportunities to get enough rest and sleep. The AIBN finds it highly probable that sleepiness, as a result of insufficient sleep and an unfavourable time of day, is an important factor in explaining this incident. Barriers that should have been in place to handle the problem of the pilot's sleepiness were weak or absent. The officer of the watch was required to deal with other tasks which distracted him from his navigational tasks, without another navigator being added to the bridge crew. In addition, the capacity of the officer of the watch to keep track of the vessel's exact position was reduced because the navigational aids in the area had been changed and corrections to the charts were not readily available to the crew. When it was discovered that the vessel was heading for the shore, it was too late to avoid running aground.

On the journey from Brevik to Slemmestad, the vessel's watertight integrity was not satisfactory. A manhole cover in the engine-room floor, which for all practical purposes is a part of the watertight bulkhead, was only fastened with two or three of a total of 24 bolts, and water entering the bow-thruster room was therefore able to flow into the engine room. This meant that the engine room of the *Crete Cement* would, relatively quickly, have been filled with so much water that the main engine would have stopped and the vessel would eventually have sunk. The decision to beach the vessel meant that this was prevented. Hence the rescue, salvage and oil-spill response actions were of a different nature than they would have been if the *Crete Cement* had sunk where the water was deep.

The AIBN proposes five safety recommendations in this report. They are addressed to the Norwegian Coastal Administration, which is recommended to implement measures to ensure that pilots have sufficient sleep and rest. It is recommended that the Norwegian Mapping Authority – Norwegian Hydrographic Service endeavour to promote international standards for the presentation of chart corrections in electronic charts. It is recommended that Bureau Veritas take operational issues into account when construction drawings of watertight bulkheads are reviewed. It is recommended that the owner (Kristian Gerhard Jebsen Skipsrederi AS) change/clarify its safety management system to ensure that the bridge is adequately manned in demanding situations. It is also recommended that the owner introduce compensatory measures on vessels where the crew have to pass through watertight bulkheads to carry out maintenance and repairs.

# 1. FACTUAL INFORMATION

## 1.1 Details about the vessel

Name	:	Crete Cement
Call signal	:	C6UP4
IMO number	:	9037161
Owner	:	KGJS Cement AS
Responsible for ISM	:	Kristian Gerhard Jebsen Skipsrederi AS
Home port	:	Nassau
Country of registration	:	Bahamas
Type	:	Cement carrier, cargo ship modified in 2006
Year of build	:	Keel laid 1990, delivered 2001
Construction material	:	Steel
Length overall	:	97 m
Draught on departure from Brevik:	:	Fore: 6.96m, Aft: 7.25m
Cargo	:	5,003 tonnes of cement
Gross tonnage	:	4,075 GT <sup>1</sup>
Engine power	:	3,648 BHP <sup>2</sup> (2,720 KW)
Bunkers on board	:	115 tonnes
Diesel on board	:	20 tonnes
Lube oil on board	:	11.5 tonnes
Classification society	:	Bureau Veritas
Insurance company (H&M) <sup>3</sup>	:	Codan Marine Norge
Insurance company (P&I) <sup>4</sup>	:	Gard

## 1.2 Details of the accident

Date and time	:	19 November 2008 at 06.31
Accident location	:	Position 59 43.37 N – 10 34.67 E. Southeast of Aspond Island in the Oslofjord
Persons on board	:	13
Injured persons/fatalities	:	None
Damage	:	Hull damage and flooding of the vessel with resulting damage to vessel's equipment and cargo
Environmental damage	:	Between 3.5 and 4 tonnes of oily slops were collected from the shore.

<sup>1</sup> Gross tonnage is calculated on the basis of the vessel's total closed-in volume.

<sup>2</sup> Brake horsepower, engine power measured at the shaft

<sup>3</sup> Hull and Machinery insurance.

<sup>4</sup> Protection and Indemnity insurance against financial claims from third parties.

### 1.3 Weather and astronomical data

#### 1.3.1 Weather data<sup>5</sup>

Air temperature	:	Between -0.5 and +1 degrees C
Relative air humidity	:	50-60 %
Wind	:	0.5 – 1.0 m/s from SW-W
Clouds and visibility	:	Completely overcast, clean air and good visibility, 75 km or more.

#### 1.3.2 Astronomical data<sup>6</sup>

Sunrise	:	08.24
Civil twilight	:	07.34
Nautical twilight	:	06.42

### 1.4 Course of events leading up to the grounding

1.4.1 The course of events has been plotted on the basis of interviews with the members of crew involved, personnel at Horten VTS and the Police. Information has also been obtained from written sources, including logbooks and other shipboard documentation, electronic information from the vessel's navigation equipment and stored data from the automatic identification system (AIS).

1.4.2 The *Crete Cement* arrived at Norcem Brevik on 18 November at 02.30 to take on board cement. Loading started at 06.30. Loading was completed at 18.30 when the vessel had taken on board approximately 5,000 tonnes of cement, and the loading hose was disconnected at 18.40. At that time the vessel was fully loaded in all three cargo holds and the fore and aft draughts were 6.96 m and 7.25 m, respectively. The *Crete Cement* departed from Norcem Brevik at 23.15 with a pilot on board, and was heading for Slemmestad. The pilot left the vessel outside Langøytingen at approximately 23.55. The reason why the *Crete Cement* did not depart before 23.15 was that the vessel was not scheduled to start unloading at Slemmestad until 07.00, and the estimated sailing time was seven and three quarter hours.

1.4.3 The voyage continued to the pilot embarkation point off Store Færder, where a new pilot was taken on board at 02.50. At that time the bridge was manned by the officer of the watch and an able seaman posted as outlook, in addition to the master who was present to help embark the pilot. The officer of the watch received the pilot on deck and brought him up to the bridge. When the pilot had been duly informed about the vessel, he reported his arrival on board to Horten VTS and asked for clearance to sail onwards into the Oslofjord. Horten VTS granted such clearance. From that point on, the pilot attended to the navigation, while the officer of the watch and the able seaman/lookout made up the rest of the bridge crew. The master went to his cabin to rest.

1.4.4 At 04.00, while the vessel was sailing within the traffic separation system from Mefjordbåen to Gullholmen, the chief mate took over as officer of the watch. The chief mate asked the pilot if he would like coffee, tea or anything to eat, but the

<sup>5</sup> Source: Norwegian Meteorological Institute.

<sup>6</sup> Source: <http://aa.usno.navy.mil/>

pilot declined his offers. There was no exchange of information relating to the voyage. The chief mate registered positions in the logbook and on the chart every hour, and was generally watchful during the voyage.

- 1.4.5 At approximately 04.15, on passing the reporting line at Tofteholmen, the pilot contacted Horten VTS again. A new clearance for sailing through the Drøbaksundet narrows to Slemmestad was granted.
- 1.4.6 At approximately 06.10 the chief mate called the chief engineer over the intercom system as the vessel was passing Oscarsborg. He then started to wake up members of crew who were to ready the hawsers etc. for mooring.
- 1.4.7 So that the deck crew would have light in which to work, the chief mate asked the pilot whether it was OK to turn on the deck lights. The pilot had no objections and the deck lights were turned on.
- 1.4.8 The pilot used the autopilot to alter the vessel's course. Both the pilot and the chief mate regarded this as normal procedure.
- 1.4.9 At 06.26, when passing Storegrunnen lighthouse, the pilot altered course to port to 333°, thus heading towards the highest point on Aspond Island. The speed at the time was between 11 and 12 knots. Around this time the chief mate called the master over the vessels' intercom system because the vessel would arrive Slemmestad in approximately half an hour.

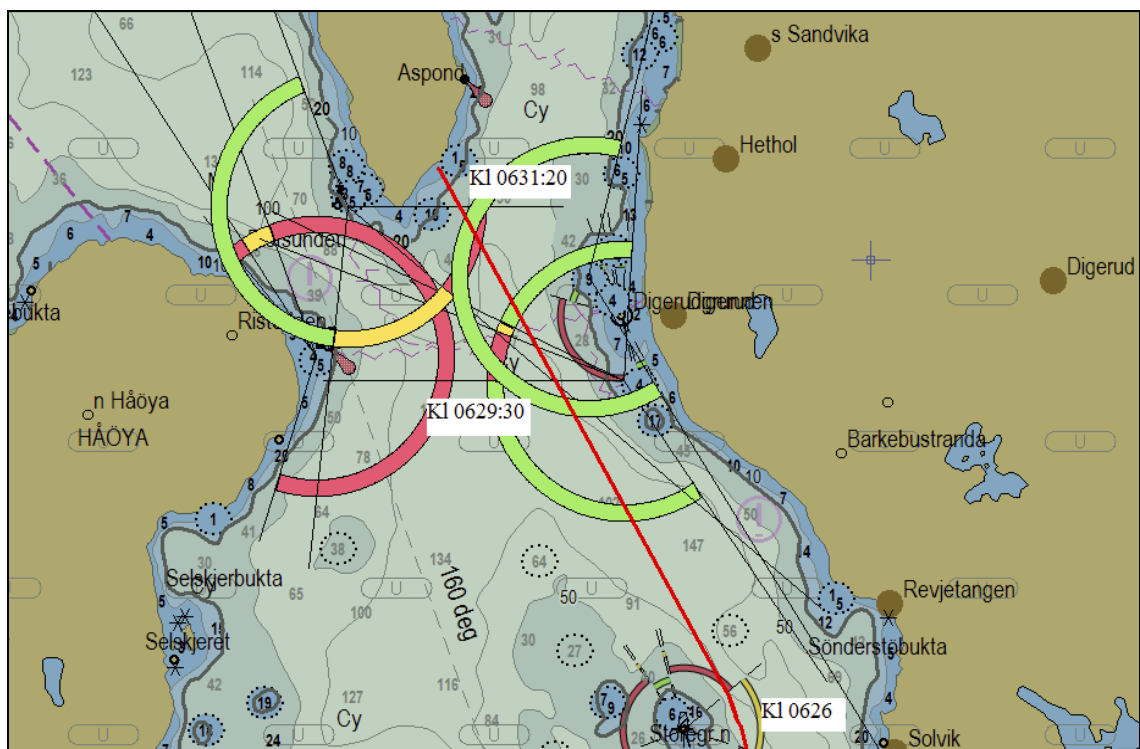

Figure 1: Crete Cement's voyage during the last few minutes before it ran aground.

- 1.4.10 At 06.29.30, the *Crete Cement* passed the Southern Digerud lighthouse. The distance to Aspond Island ahead was approximately 0.4 nautical miles. At this point the course should have been altered to starboard, but this did not happen. At approximately 06.30.25 the vessel passed WP 20, and signals were emitted by the



GPS. An estimated 30-40 seconds later, the chief mate called out to the pilot who jumped and then started to alter course to starboard using the autopilot. The chief mate gave the orders to change to manual steering, and this was done by the lookout. Hard starboard was ordered, and the helm was put hard to starboard. The vessel started to turn starboard, but after a few seconds, a powerful impact was felt and the bow swung hard to starboard. The time was then approximately 06.31.20. Some witnesses stated that they thought they felt a second, weaker impact after the first one – this has neither been possible to confirm nor exclude.

- 1.4.11 The master proceeded to the wheelhouse immediately. The chief engineer ran down to the engine room and arrived there about 15-20 seconds after the vessel ran aground. He observed water flowing in through the manhole leading to the pipe trunk between the engine room bulkhead and the bow thruster room. This manhole is located near the forward bulkhead of the engine room. He did not observe any other ingress of water to the engine room at that time. The second engineer also came to the engine room. The chief engineer then ran up to the bridge and informed that there was ingress of water in the engine room.
- 1.4.12 The chief mate was sent down on deck to dip the tanks and check for ingress of water at the bow. The second engineer was ordered to switch from the shaft generator to the auxiliary engine for power supply. This was done.
- 1.4.13 The pilot used his mobile to call Horten VTS to inform about the grounding and the intention to proceed to the quay at Slemmestad. A northerly course was set and the speed was gradually increased.
- 1.4.14 The chief mate reported that there was ingress of water in ballast tank no. 1 (starboard and port), in the forepeak and in the bow-thruster room. He could also hear the sound of water flowing in and forcing out the air from these spaces.
- 1.4.15 It eventually became clear that the draught was increasing relatively quickly both fore and aft due to the ingress of water and, at 06.42, the pilot asked Horten VTS for details regarding the beaching site off Fagerstrand.
- 1.4.16 On the basis of the information received, the pilot, with the consent of the master, decided to turn the vessel around and head for Grisebukta, just south of the marina at Fagerstrand. The pilot contacted Horten VTS again and informed that the *Crete Cement* was taking in water and that he would beach the vessel in Grisebukta. He wanted the traffic control centre to confirm that Grisebukta was a pre-designated beaching site that could be used in this case. After having consulted the Norwegian Coastal Administration's emergency plans, the traffic control centre confirmed that Grisebukta was a pre-designated beaching site. It was decided to beach the vessel and, at 06.44, the *Crete Cement* was put hard to starboard and headed south towards Grisebukta. When approaching from the north, the best beaching site is blocked by the leisure craft marina at Fagerstrand, so the pilot chose to sail slightly further south for the beaching.

## **1.5 The rescue action**

- 1.5.1 The Joint Rescue Coordination Centre for Southern Norway (RCC-S) was informed of the situation by Horten VTS at 06.52. RCC-S contacted the rescue vessel *Odd*

*Fellow II*, which was moored at Kaholmen (in Oscarsborg). The *Odd Fellow II* was asked to proceed to the vessel in distress as soon as possible.

- 1.5.2 The tugboat *Balder* was moored at Vippetangen in Oslo. At 06.55, Horten VTS asked the *Balder* to proceed to the distressed vessel as soon as possible; *Balder* departed at approximately 06.59.
- 1.5.3 The *Crete Cement* was beached south of Fagerstrand at approximately 06.59. The forepeak was grounded so the fore draught was stable. The stern was still afloat, but the aft draught was increasing as more water flowed into the vessel.
- 1.5.4 The *Odd Fellow II* arrived at the distressed vessel at 07.17. The *Odd Fellow II* measured the depth around the *Crete Cement*'s afterbody, and found that it was 13.2 metres at the stern. The *Odd Fellow II* also observed that the aft draught of the *Crete Cement* continued to increase.
- 1.5.5 In time, more vessels and a rescue helicopter arrived. At 07.50, RCC-S ordered crew members who were not needed on board the *Crete Cement* to prepare for evacuation. RCC-S encountered problems when trying to make direct contact with the ship, but this was solved by Horten VTS conveying the order through the pilot. Evacuation of some of the crew started at 07.53. At 08.12, ten crew members had been evacuated to the work boat *Gyltingen*.
- 1.5.6 The aft draught continued to increase as the time passed, and it was feared that the vessel would slip away from the beaching site. There was also a reluctance to push too hard against the afterbody using the boats that had gathered at the site, because of the uncertainty about the stability of the *Crete Cement* at that time. At 08.23, the situation on board was considered to be so uncertain, that it was decided to evacuate those remaining on board to the *T/B Balder*. The evacuation was completed at 08.30.
- 1.5.7 RCC-S closed the rescue action at 08.32 and responsibility for further action was transferred to the Norwegian Coastal Administration (NCA).

## **1.6 Damage to the vessel and ingress of water**

- 1.6.1 The information is based on interviews with people from Smit Salvage, K.A.J. Dykkertjeneste (including video recordings), Buksér og Berging AS, the crew and our own investigations. The AIBN has not inspected the *Crete Cement* in dry dock after the grounding.
- 1.6.2 The *Crete Cement* was turning to starboard as it ran aground. The seabed where it ran aground consists mainly of rock, and the impact on the hull was therefore considerable. The *Crete Cement* sustained damage to the bow, initially leading to ingress of water in the forepeak, bow-thruster room and ballast tanks no. 1 starboard and port. The damage extended from frame 110 to frame 123 (over a distance of approximately 9 metres). Most of the damage was sustained on the port side, but starboard ballast tank no. 1 was also punctured and took in water.
- 1.6.3 The design of the *Crete Cement* incorporates a pipe trunk alongships from the bow-thruster room to the engine room. The middle part of this pipe trunk is located under the blow tank tunnel. Inside the pipe trunk, which is approximately one





*Figure 4: Manhole cover from the blow-tank tunnel towards the void below the cargo hold.*

- 1.6.6 Water flowed into cargo holds 2 and 3, both starboard and port. The water probably flowed in through access hatches from the trunk deck (over the main deck) and the main deck after these decks were submerged. Water may also have entered through the discharging pipes, but this is less likely. In that case, water would most likely also enter cargo hold 1.



Figure 5: From cargo hold 3 after the water was pumped out and the cement had set. (Photo: DNV)

1.6.7 Figures 6 and 7 show how the *Crete Cement* was flooded with water after running aground. The areas highlighted in blue were flooded within a short period of time, while it took somewhat longer for the areas highlighted in red to become flooded.



Figure 6: Flooding of vessel after running aground (scenario 2a).

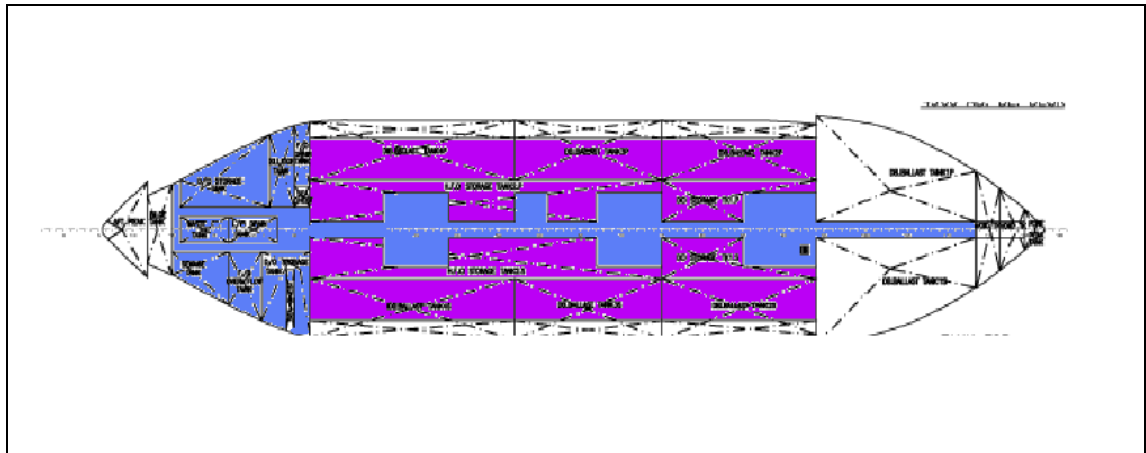

Figure 7: Flooding of vessel after running aground (scenario 2a).

- 1.6.8 The Emergency Response Service (ERS) from Det Norske Veritas has carried out calculations of the vessel's buoyancy and stability given water ingress in various holds/sections of the vessel. See Annex C. The scenario describing the situation after the vessel ran aground (scenario 2a, flooding of the forepeak, ballast tank 1 starboard (SB) and port-side (PS), pipe trunk, blow-tank tunnel, bow-thruster room, voids below cargo holds 2 and 3 SB and PS, engine room, compressor room and accommodation area of the main deck aft) indicates that the *Crete Cement* would have sunk. The vessel would not have sunk immediately because it would have taken some time for all the holds to become completely flooded, but the *Crete Cement* would have lost propulsion at an early stage as a result of the seawater flooding the engine room and causing the main engine to stop. The vessel would then have drifted with no means of propulsion or manoeuvring until it sank.

## 1.7 Oil-spill response following the grounding

- 1.7.1 The vessel ran aground during a turn to starboard at approx. 06.31.20 and continued to turn to starboard and back into the fairway. The pilot stopped the engines and the vessel was left lying across the fairway with the bow pointing in an easterly direction. The pilot phoned Horten VTS and informed them that the vessel had run aground, but that they intended to proceed to Slemmestad. At approx. 06.36, the pilot steered the vessel to port and increased the speed heading north towards Slemmestad. As the vessel was passing the northerly tip of Aspond Island, the chief engineer arrived on the bridge and announced that the vessel was taking in a great deal of water in the engine room. At the same time, the pilot observed that the vessel's bow was beginning to get heavy, and the forward draught was increasing.
- 1.7.2 After having been informed by the pilot about the considerable amount of water ingress and his wish to beach the vessel in the Grisebubukta bay, the VTS initiated measures and notification in accordance with its own operating procedures<sup>7</sup>. The tugboat *Balder*, which was moored in Oslo, was notified and requested to set course for Fagerstrand. The Joint Rescue Coordination Centre, the master pilot and the emergency response team on duty were notified of the incident. Other local resources arrived quickly; for example, the rescue vessel *Odd Fellow II*, which arrived at Grisebubukta at 07.17 and the tugboat *Gyltingen* which arrived at 07.55.

<sup>7</sup> Standard operating procedures for Horten Vessel Traffic Service (SOP for Horten VTS).

- 1.7.3 From 07.00, the response action was coordinated by the Joint Rescue Coordination Centre – South Norway (RCC-S). Follo Police Authority established a local rescue coordination centre, and appointed a response team leader, who arrived at Fagerstrand just after 08.00. The response team leader set up operations in premises made available to the response action leadership by Statoil Fagerstrand.
- 1.7.4 The crew and the pilot on board the *Crete Cement* were evacuated and the joint Rescue Coordination Centre concluded its rescue efforts at 08.32. Responsibility for handling the incident was then handed over to the Norwegian Coastal Administration's emergency response section and the inter-municipal committee against acute pollution (IUA) for the inner Oslofjord. After observing that the ship was relatively stable, the pilot and some of the ship's key personnel re-entered *Crete Cement*. During this period the pilot in many ways acted as local response team leader, without the situation being formalized in any way.
- 1.7.5 Throughout the morning, the NCA's emergency response section maintained close contact with IUA for the inner Oslofjord, which was headed by the Chief Officer of the Oslo Fire Service. The IUA for the inner Oslofjord was in charge of the local rescue and oil-spill response on behalf of the NCA. The NCA focused on mobilising a sufficient number of relevant resources to deal with any oil pollution. The commanding officer on board the Norwegian Coast Guard vessel *Nornen* was appointed on-scene commander.
- 1.7.6 The *KV Nornen* arrived at Fagerstrand with an adviser from the NCA on board, held a meeting with local pollution response resources in the area and assumed responsibility for oil-spill response at approx. 15.00. The NCA's further involvement in dealing with the grounded vessel included maintaining adequate oil-spill emergency resources, and supervising the owner's work to refloat and remove the vessel in collaboration with the Norwegian Maritime Directorate (NMD).
- 1.7.7 Interviews with those involved locally at Fagerstrand indicate that there was uncertainty as to who was in charge locally during the period between the joint Rescue Coordination Centre concluding the rescue action (at 08.32) and the *KV Nornen* taking over responsibility (at approx. 15.00). As the joint Rescue Coordination Centre was concluding its response, the Police's local rescue coordination centre concluded its operations. From that point onwards, the task of the police was limited to cordoning off and securing the area; they played no role directly related to the NCA's response action.



Figure 8: The *Crete Cement* during the oil-spill response action. (Photo: the Norwegian Coastal Administration).

1.7.8 The oil-response action after the grounding included debunkering the vessel, deploying booms, collecting oil inside the booms and the collecting oily slops and oil emulsion along the coastline. In this case, between 3.5 and 4 tonnes of oily slops were collected from the coastline. The rest of the oil was handled without impacting the environment, by means of emergency debunkering and collection from the area inside the booms.

1.7.9 The exact cost of the action is not clear, but will probably lie somewhere between NOK 15 million NOK 25 million. By comparison, the *Server* response action cost approx. NOK 220 million, the *Rocknes* response action cost approx. NOK 139 million<sup>8</sup>, and the debunkering of the *Blücher* in 1994 cost approx. NOK 75 million.<sup>9</sup>

## 1.8 The shipping company

1.8.1 At the time of the accident, Kristian Gerhard Jebsen Skipsrederi AS (KGJS) was operator for the *Crete Cement* and responsible for ISM. The owner has its head office in Bergen, and has branches and representatives in Antwerp, Bangalore, Manila, Mumbai, Rio de Janeiro, Shanghai and Singapore. Kristian Gerhard Jebsen Skipsrederi AS was founded in 1967, and is today one of Norway's largest shipping companies, in terms of both turnover and the number of vessels in its fleet.<sup>10</sup> It

<sup>8</sup> Source: Norwegian Coastal Administration's treatment of the acute oil pollution from the cargo ship the *M/S Server*. External evaluation. Norconsult, 15 September 2008.

<sup>9</sup> Source: The Norwegian Coastal Administration's report *Status 2006 for tidligere undersøkte vrak med potensiell olje langs norskekysten* ('Status 2006 of previously examined wrecks potentially containing oil along the Norwegian coastline' – in Norwegian only) section 4.3.2.

<sup>10</sup> Source: Kristian Gerhard Jebsen Skipsrederi AS's website.



operates approximately 135 vessels, in addition to following up new builds and modification projects. The owner is also involved in the operation of ports, terminals, barges and other cargo handling.

- 1.8.2 The *Crete Cement* was owned by KGJ Cement, which, in turn, was owned by Kristian Gerhard Jebsen Skipsrederi AS. At the time of the accident, the fleet of cement carriers comprised 31 vessels, in the range from 1,725 DWT<sup>11</sup> to 28,929 DWT. The *Crete Cement* had a sister ship, the *Cyprus Cement*, with which it is identical, with the exception of a few minor details.
- 1.8.3 The owner's documentation and working language is English, and this also applies to the vessels.

## 1.9 The owner and vessels' safety management system

- 1.9.1 At the time of the accident, Kristian Gerhard Jebsen Skipsrederi AS (KGJS) held a valid Document of Compliance (DOC) in accordance with IMO's ISM Code<sup>12</sup>. The original certificate had been issued by Det Norske Veritas on 9 November 2004, and the present certificate was valid until 12 October 2009. The owner was certified in accordance with ISO 9001<sup>13</sup> and ISO 14001<sup>14</sup>. The expiry date of these certificates was 18 November 2008.

- 1.9.2 The owner has a comprehensive safety management system. This primarily consists of the following four parts:

- Joint manuals for the cement fleet (Shipboard Main Manuals Cement Vessels)
- Vessel-specific manuals
- Contingency plans
- Ship Circulars

Furthermore, activities on board will also be controlled by orders and instructions from the operator (Charterer's Instructions), but, strictly speaking, the latter do not form part of the safety management system.

- 1.9.3 KGJS uses a standardised reporting system – the Safety and Improvement Reporting system (SAFIR). In the year before it ran aground, the *Crete Cement* submitted three (3) non-conformity reports to the owner. These dealt with two cases involving minor personal injuries and one incident of damage to cargo sustained in connection with unloading.
- 1.9.4 The presence of the master on the bridge is dealt with in the safety management system. Procedure 19.02 is cited below in its entirety:<sup>15</sup>

---

<sup>11</sup> Dead Weight Tonnage – a measure of the total carrying capacity of a vessel.

<sup>12</sup> International Safety Management Code, IMO Res. A 741 (18)

<sup>13</sup> Quality Management Standard NS-EN ISO 9001:2000 for ship management and technical operation of ships

<sup>14</sup> Environmental Standard NS-EN ISO 14001:1996 for ship management and technical operation of ships

<sup>15</sup> Source: KGJS Shipboard Main Manual for Cement Vessels.

*Master, in making voyage plans prior to a voyage and throughout a voyage as conditions may dictate, must maximise his direct presence on the bridge for the following conditions:*

- *Whenever there is a pilot on board*
- *Whenever approaching or leaving pilot area*
- *Whenever entering or leaving a port without a pilot*
- *When navigating in enclosed narrow waters*
- *When navigating in heavy traffic*
- *During periods of reduced visibility, regardless of area*
- *Whenever navigating in separation zones or approaching them*
- *During periods of extreme heavy weather*
- *Whenever navigating in ice or derelicts or when the ship meets any other hazard to navigation*
- *During emergency situations at sea*

1.9.5 Procedures for collaboration between the bridge crew and the pilot are described in the safety management system. The following is an excerpt from procedure 19.06<sup>16</sup>:

***Pilot On board***

*The pilotage passage plan will need to be discussed with the pilot as soon as he comes onboard. Any amendments to the plan should be agreed and any consequential changes in individual bridge team responsibilities made before pilotage commences. Where pre-arrival exchange has not taken place extra time and sea room may need to be allowed before pilotage commences in order to discuss the plan fully. The pilot shall be handed the Pilot Card and shown the wheel house poster.*

***Responsibilities***

*Depending on local pilotage laws, the Master may delegate the conduct of the vessel to the pilot who directs the navigation of the vessel in close co-operation with the Master and/or the OOW. It is important that the responsibilities of the pilot and the Master are agreed and clearly understood. The presence of a pilot does not relieve the Master or the OOW of their duties and obligations for the safety of the vessel. Both should be prepared to exercise their right not to proceed to a point where the vessel would not be able to navigate, or would be in danger.*

**1.10 Crete Cement**

1.10.1 History

1.10.1.1 The *Crete Cement*'s keel was originally laid on 1 November 1989 at Damen Shipyard Galati in Romania under the supervision of the classification society Russian Maritime Register of Shipping. The hull was built, but the ship was not

<sup>16</sup> Source: KGJS Shipboard Main Manual for Cement Vessels.

fully fitted out. The hull was launched on 21 October 1991<sup>17</sup>, under the name *Mironych*.

- 1.10.1.2 On 25 February 2002, the ship was delivered as a cargo vessel, fully fitted out, from the Yildirim Gemi Insaat San AS shipyard in Tuzla, Turkey. It still bore the name *Mironych*. On 14 June 2002, the vessel was renamed *Dogu EM*, and Bureau Veritas became the new classification society. In October 2004, the name was changed to *Kamer 3*. The vessel probably also sailed under the name *Sider Fly* for a while, but this has proved difficult to verify.<sup>18</sup>

The vessel was renamed the *Crete Cement* on 13 June 2005, and was registered in the Bahamas on the same date<sup>19</sup>, with Nassau as its home port.

#### 1.10.2 Design and conversion to cement carrier

- 1.10.2.1 Until April 2006, the vessel was a regular cargo vessel. The drawings for the conversion to a cement carrier were approved by Bureau Veritas. Some of these drawings are included in Annex B. Between 19 April and 8 November 2006, the vessel was converted into a cement carrier at the Pan United Shipyard in Batam, Indonesia. Bureau Veritas continued to be the classification society during and after the conversion.

- 1.10.2.2 Among other things, the design of this type of ship is regulated by the SOLAS Convention<sup>20</sup> and the Load Line Convention<sup>21</sup>. The classification societies also draw up requirements for the vessels based on these provisions. Pursuant to SOLAS Chapter II-1, Regulation 11, vessels of the *Crete Cement*'s type and size must have three watertight bulkheads: a collision bulkhead fore, a machinery space bulkhead (forward of the engine room) and a stern tube bulkhead (abaft of the engine room). The *Crete Cement* met the requirements with a collision bulkhead at frame 120, engine room bulkhead at frame 32 and stern tube bulkhead at frame 4. See figure 9. In addition to these, there were transverse watertight bulkheads at frames 94, 61 and 57.

---

<sup>17</sup> Source: [www.sea-web.com](http://www.sea-web.com).

<sup>18</sup> Source: Form 'T/C description'

<sup>19</sup> Source: [www.equasis.org](http://www.equasis.org)

<sup>20</sup> International Convention for the Safety of Life at Sea, 1974, with subsequent amendments and addendums.

<sup>21</sup> International Convention on Load Lines, 1966, with subsequent amendments and addendums.

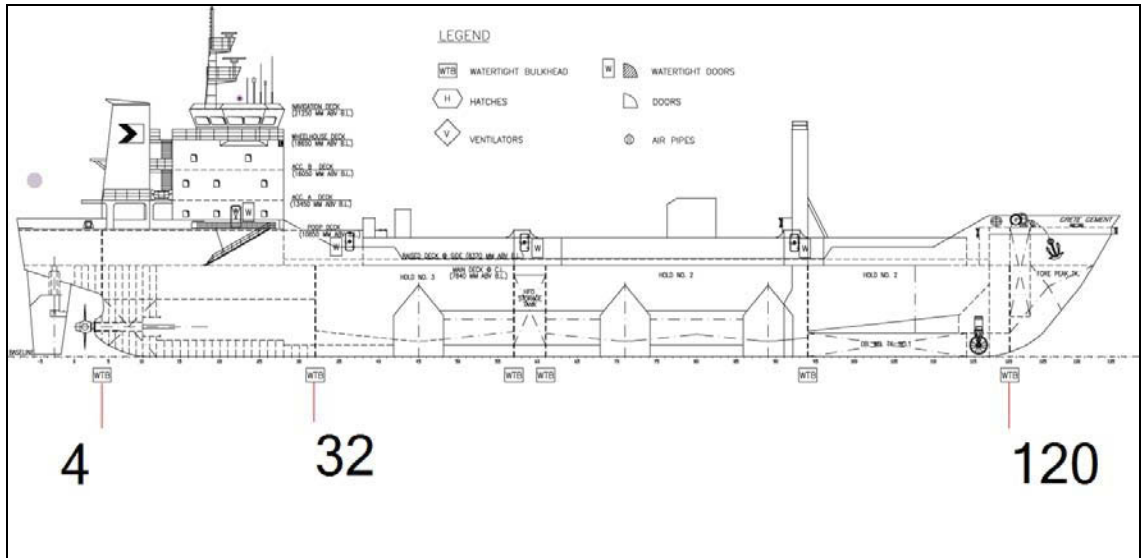

Figure 9: Watertight compartments by virtue of the positioning of the mandatory watertight bulkheads.

1.10.2.3 When the *Crete Cement* was converted to a cement carrier, a blow-tank tunnel was constructed that contains three blow tanks. There is no watertight barrier between the blow-tank tunnel and the pipe trunk that runs from the bow-thruster room to the engine room.



Figure 10: Connection between the blow-tank tunnel and the pipe trunk.

1.10.2.4 Figure 11 shows the arrangement of blow tanks, the blow-tank tunnel and the pipe trunk. The blow-tank tunnel is shaded green, and the pipe trunk red. The figure shows an alongships section along the vessel's centreline.



Figure 11: The blow-tank tunnel (green) and the pipe trunk (red).

1.10.2.5 Because it is not possible to close the hatches shown in figure 10 so that they are watertight, any water ingress into the bow-thruster room will lead to flooding of the spaces shown in figures 12 and 13, provided that all watertight sections are intact.

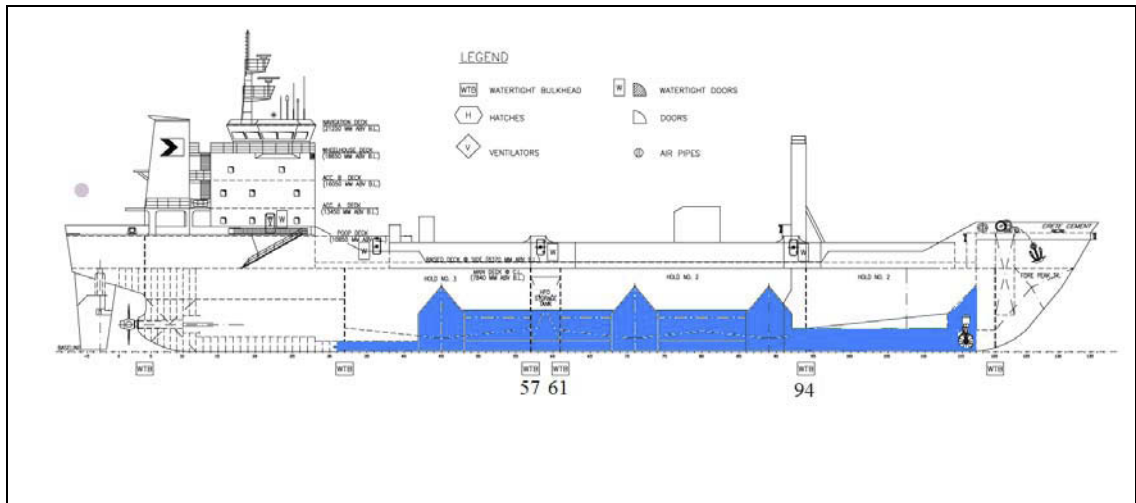

Figure 12: Flooded spaces following water ingress into the bow-thruster room, provided that all watertight sections are intact.

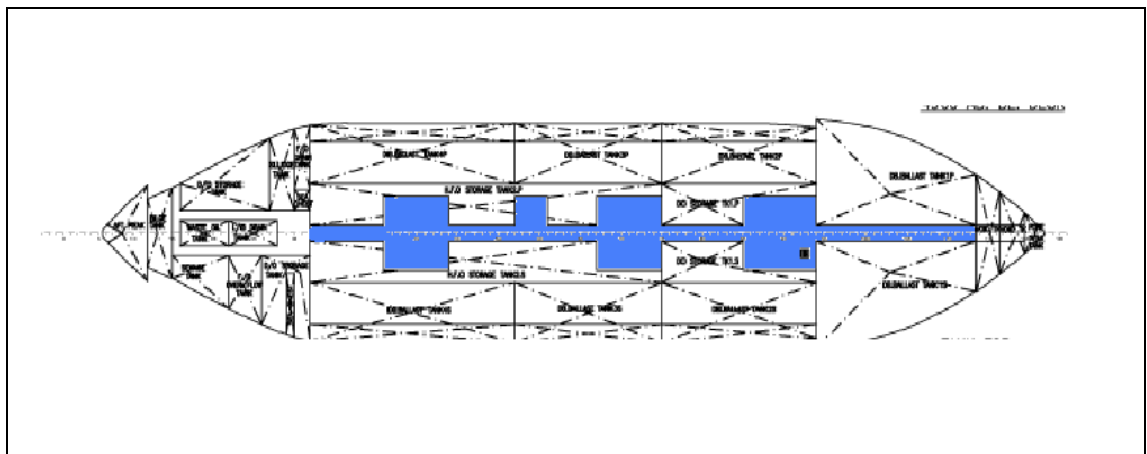

Figure 13: Flooded spaces following water ingress into the bow-thruster room, provided that all watertight sections are intact. Viewed from above, the aft is to the left.

As can be seen from the above illustrations, the watertight bulkheads at frames 94, 61 and 57 are ineffectual in terms of preventing further flooding in this area subsequent to any water ingress into the bow-thruster room. Calculations performed by DNV show that the vessel will float with sufficient buoyancy and stability even after being flooded as shown in figures 12 and 13.

- 1.10.2.6 In connection with the conversion to a cement carrier, additional stability calculations were performed (Preliminary probabilistic and Final probabilistic stability booklet) by Shiptech PTE (Singapore) in accordance with the stability requirements in SOLAS<sup>22</sup>. The calculations have been approved by the classification society, and the AIBN assumes that they are correct.
- 1.10.2.7 The pipe trunk between the bow thruster room and the engine room is approximately one metre high, and between one and five metres wide. The widest areas are where the blow tanks are located. These spaces contain various pipes and cables, primarily pertaining to the ballast and bilge equipment.



Figure 14: Photo of the pipe trunk.

- 1.10.2.8 There are open voids below the cargo holds because of their shape. The bottoms of the cargo holds are not entirely level, but have a gradient towards the opening through which the cement is discharged. These open voids are highlighted in blue in figure 15.

---

<sup>22</sup> SOLAS Part B-1, Regulation 25-1.

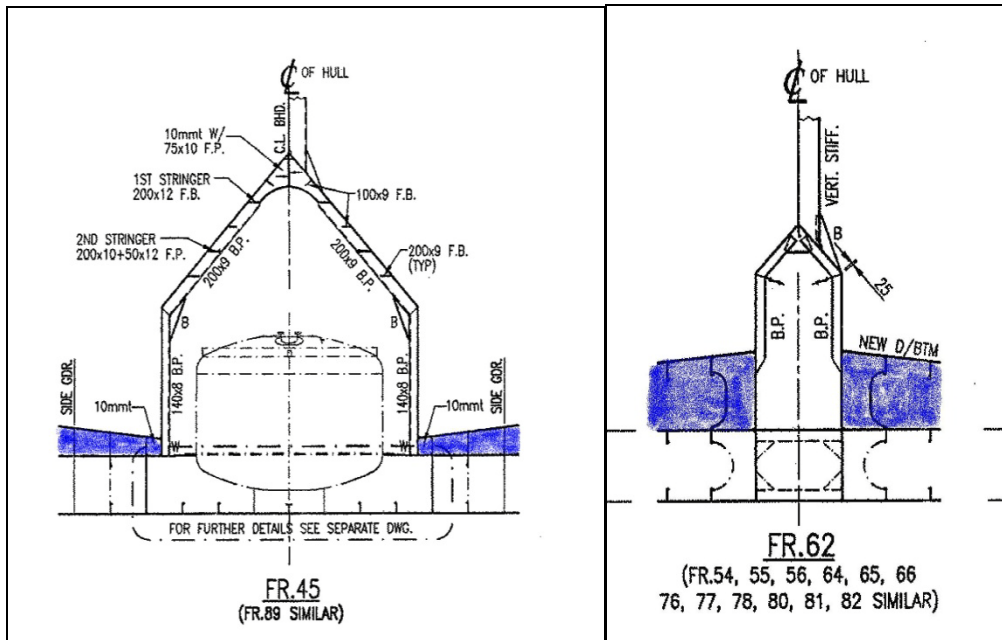

Figure 15: Cross section of blow-tank tunnel by the blow tank (frame 45) and between the blow tanks (frame 62). Voids are marked in blue.

1.10.2.9 From the blow-tank tunnel, the voids below the cargo holds can be accessed via manholes. The manhole covers have 24 fixing bolts. The manhole covers are watertight if correctly installed. Figure 16 shows one of these manhole covers.



Figure 16: Manhole cover for access to void.

- 1.10.2.10 The pipe trunk has also been extended through the engine room bulkhead and ends in an almost square manhole cover inside the engine room.



Figure 17: Manhole cover in engine room for access to the pipe trunk.

This manhole cover arrangement also has 24 fixing bolts, and it is used for access to the aft part of the pipe trunk. This is required in connection with maintenance and controls of the bilge and ballast equipment. According to the crew, they may want to get into the tunnel an average of three or four times a week, often at short intervals. This is why the cover was not fastened with all the bolts; it was often fitted loosely with just two or three bolts.

### 1.10.3 Inspection history

- 1.10.3.1 There were two port state inspections of the *Crete Cement*<sup>23</sup> in the course of 2008<sup>24</sup>. They were both carried out in Drammen – one on 21 February and the other on 5 September. The inspection on 21 February found a minor non-conformity in relation to the regulations relating to fire-extinguishing equipment. The vessel was granted permission to sail following the inspection. The inspection on 5 September found six non-conformities, but none of these were deemed serious enough to detain the vessel.
- 1.10.3.2 One of the non-conformities related to inadequate updating of some of the charts, but it was of no relevance to the incident under investigation.

<sup>23</sup> Pursuant to the Paris Memorandum of Understanding on Port State Control (the Paris MoU).

<sup>24</sup> Source: 'Equasis' - European maritime safety database.



## **1.11 The Crete Cement's crew**

### **1.11.1 Master**

The master was 36 years old, had been employed by KGJS since March 2005 and as a master since November 2005. His first period as master of the *Crete Cement* started in December 2007. He started the relevant period on board on 14 November. He had all the requisite certificates to hold the position of master.

### **1.11.2 Chief mate**

The chief mate was 35 years old, and had been employed as chief mate on board the *Crete Cement* since December 2007. He started the relevant period on board on 2 October. He had all the requisite certificates to hold the position of chief mate.

### **1.11.3 Chief engineer**

The chief engineer was 53 years old, and had been employed by KGJS as chief engineer on various vessels since 12 June 2000. He had been employed as chief engineer on the *Crete Cement* since 30 November 2006 and started the relevant period on board on 13 October 2008. He had all the requisite certificates to hold the position of chief engineer.

### **1.11.4 Lookout**

An able seaman, 38 years old, was on watch as lookout. He had been employed on board the *Crete Cement* for approximately three months. During the voyage, he stayed close to the steering consol so that he could switch from autopilot to manual steering if necessary, and then take on the tasks of the helmsman.

## **1.12 Charts**

### **1.12.1 Paper charts**

- 1.12.1.1 The *Crete Cement* used nautical charts from the British Admiralty (BA) as official navigation charts. The vessel's official BA chart over the relevant area had been updated with the most recent corrections. Corrections to BA charts do not include temporary ('T') or provisional ('P') corrections in Norwegian waters. The lighthouse modifications at Digerud were therefore not reflected on the vessel's official charts.

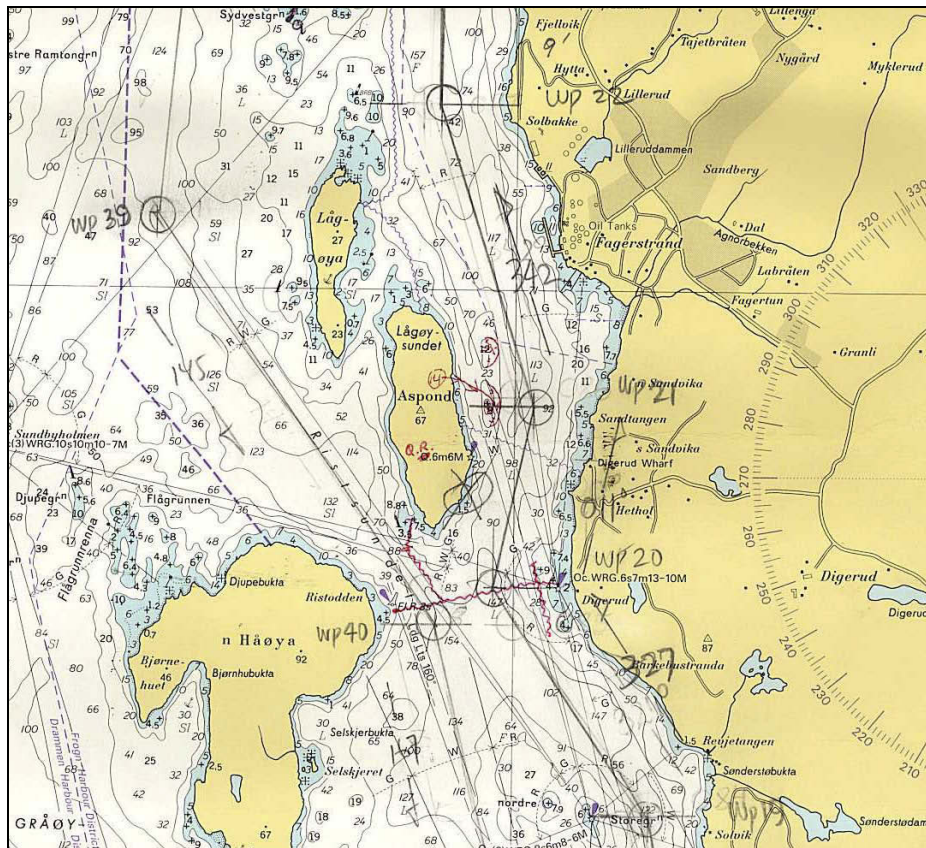

Figure 18: Detail from the Crete Cement's chart BA 3563. (not to scale.)

1.12.1.2 There were also some Norwegian charts on board. They included nautical chart no. 402 (Spro – Filtvet), which covered the relevant area. This is a detailed chart, scaled on 1:25,000, printed in August 2006. When printed, the chart had been updated with corrections up to and including *Etterretninger for Sjøfarende (EfS)* (Norwegian Notices to Mariners) no. 16/2006. Norwegian EfS notices had been subscribed to since July 2007, so it was not possible for the crew on the *Crete Cement* to update the chart with all corrections made after the printing date. Some of the EfS notices on board contained information about construction work in the Oslofjord, but chart no. 402 had not been updated with this information (ref. section 1.18).

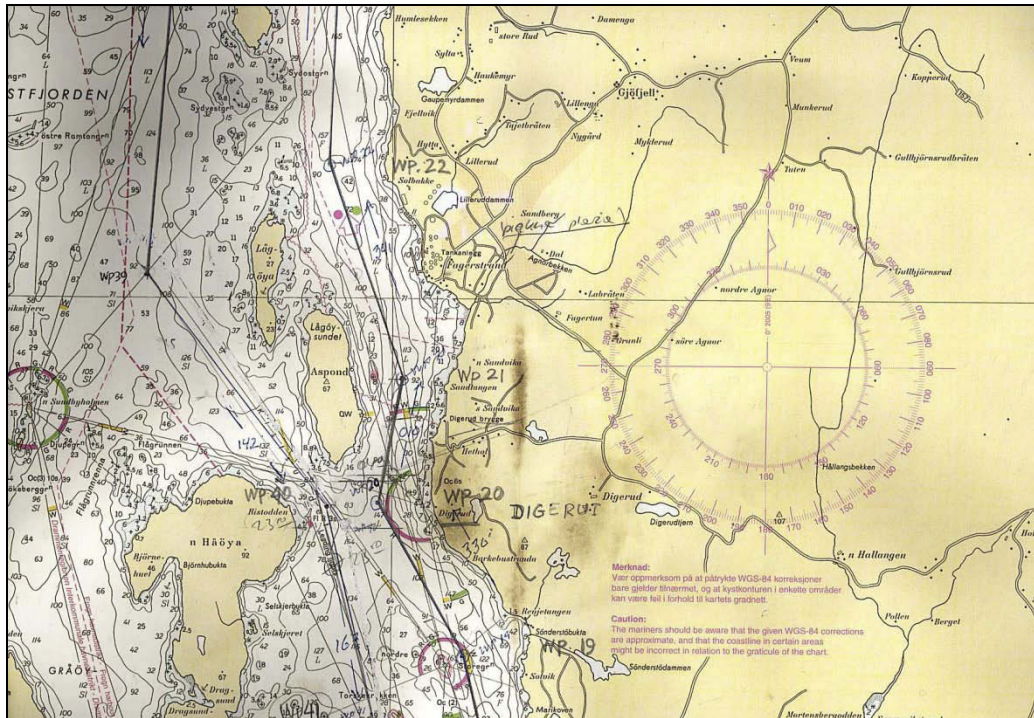

Figure 19: Detail from the Crete Cement's chart BA 402. (not to scale.)

### 1.12.2 Electronic charts

1.12.2.1 The *Crete Cement* also had an electronic chart system of the type C-Map CM-93 Professional +. This was installed on a Sperry Marine Vision Master FT - a combined radar and electronic chart system. This chart solution was not in accordance with the ECDIS standard<sup>25</sup> and could not have been used as the vessel's official charts. The electronic charts had been updated as far as week no. 45, 2008. The updates did not contain any information about the erection of new lighthouses at Digerud (ref. section 1.18). Nor would this information have been available through the update service for ENC if official electronic charts had been used, since Norwegian 'T' and 'P' corrections are not presented in electronic charts.

### 1.12.3 Route planning

The inbound voyage plan to Slemmestad was marked by waypoints in both sets of paper charts and in the electronic chart system.

## 1.13 **Operation of the loading/discharge system**

1.13.1.1 A ship requires maintenance. Cement is a type of cargo that wears out loading and discharge equipment. When cement is loaded and discharged using air pressure, valves etc. often have to be manually operated. There is also a need to replace and maintain parts of the loading/discharge system. The crew on board the *Crete Cement* stated that they normally needed access to pipes and valves below the cargo holds several times a week and, during some periods, as often as every other day. Access to these areas was required because a valve might get stuck or need to be

<sup>25</sup> IMO Resolution A.817(19). Performance standards for electronic chart display and information systems (ECDIS)

operated manually, or because some part of the system was in need of repair or replacement.

- 1.13.1.2 Access to the blow tank tunnel is via access hatches from the main deck and the trunk deck (the deck above the main deck) The main part of the discharge system is located here and in the void areas below the cargo holds Access to the void areas is via watertight manholes in the blow tank tunnel. All these manhole covers must be fastened with 24 bolts in order to be watertight.

**1.14 Watertight integrity of the Crete Cement on running aground.**

- 1.14.1.1 The following information is based on interviews with the crew and information provided by salvage personnel in Smit Salvage and Bukser og Berging.
- 1.14.1.2 At the time when it ran aground, the *Crete Cement* had an intact and operative collision bulkhead at frame 120, at the forward end of the bow-thruster room. At the aft end of the bow-thruster room, there is an opening to the pipe trunk which cannot be closed. In the pipe trunk there were open hatches to the blow-tank tunnel. In the blow-tank tunnel, there were bolted, watertight manhole covers towards the voids under cargo hold 1, but open manhole covers towards the voids under cargo holds 2 and 3. In the engine room, the manhole cover towards the pipe trunk had been loosely fitted using two or three bolts. The engine room’s manhole cover towards the port-side passageway was open. It is assumed that the stern tube bulkhead was intact, but we have not looked into this and it had no bearing on the incident under investigation.
- 1.14.1.3 Figures 20 and 21 show the spaces that were flooded after the *Crete Cement* ran aground. The spaces highlighted in blue were flooded after a short period of time, estimated to between 30 and 45 minutes; while the spaces highlighted in pink show the spaces that were gradually flooded with water in the course of a few hours.

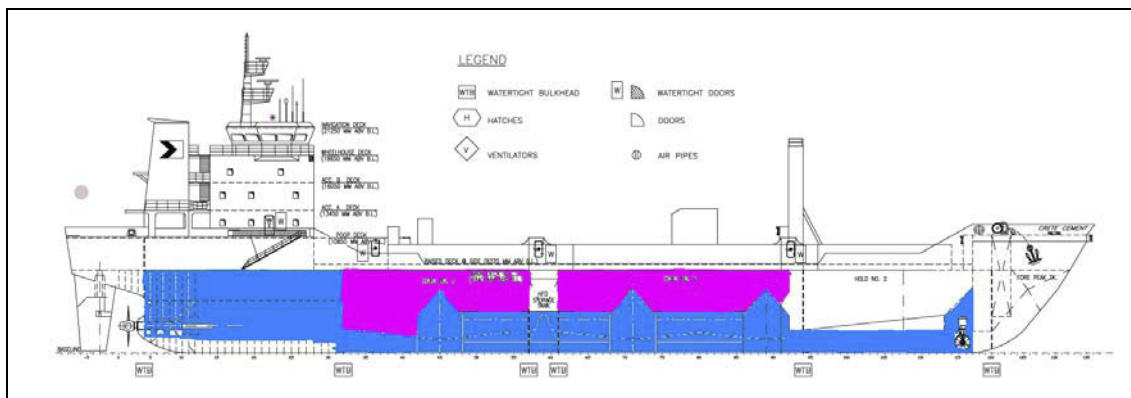

Figure 20: Flooded spaces.

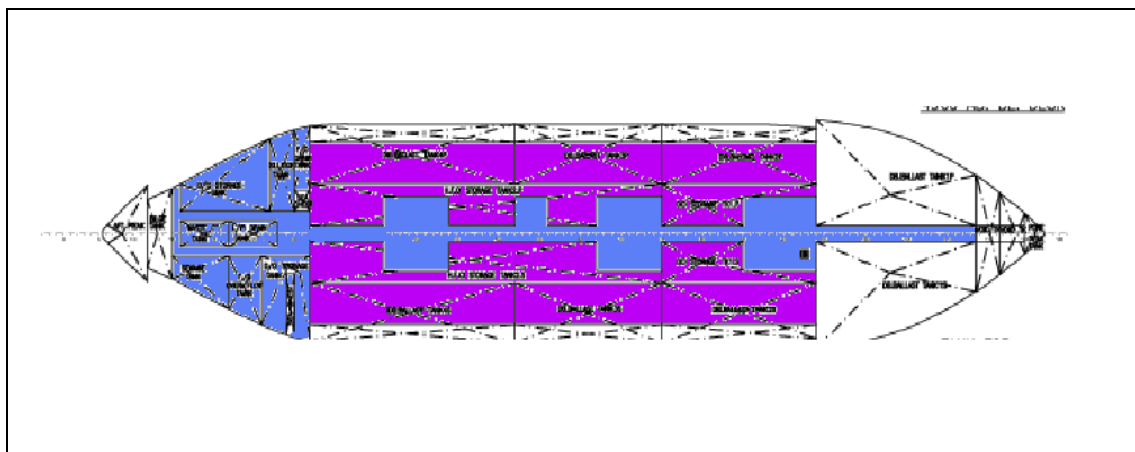

Figure 21: Flooded spaces.

## 1.15 Rescue actions in Norway<sup>26</sup>

- 1.15.1 The overriding principles on which the Norwegian rescue service is based and organised are laid down in a Royal Decree of 4 July 1980. The Police's coordinating duties in accident and disaster situations that threaten human life or health are provided for in the Norwegian Police Act of 4 August 1995 section 27. Important rules relating to rescue and ambulance services are also contained in the Criminal Code, the Civil Defence Act, the Act relating to the home guard, health and insurance legislation, the Act relating to medical practitioners, the Act relating to the prevention of fire, explosion and accidents involving hazardous substances and the fire service, the Maritime Act, the Petroleum Activities Act and the Coast Guard Act.
- 1.15.2 Rescue actions are led by the relevant joint rescue coordination centre and local rescue coordination centers consisting of representatives of several public services and headed by the local chief of police. The local police station is the local rescue coordination centre. It will normally have a response team leader based as close to the action as practically possible. In this case the response team leader was based in Fagerstrand, where he operated from premises made available by Statoil Fagerstrand.

## 1.16 Emergency preparedness against acute pollution

### 1.16.1 General

1.16.1.1 In Norway, emergency response is the responsibility of three parties:

1. Private emergency response
2. Municipal emergency response
3. State emergency response.

1.16.1.2 The Norwegian Coastal Administration shall be able to take over an action in part or in whole if private or municipal emergency response is inadequate. In such cases,

<sup>26</sup> Source: [www.hovedredningssentralen.no](http://www.hovedredningssentralen.no)

private, municipal and state response organisations will combat the spill together, under the leadership of the NCA. The NCA has entered into collaboration agreements so that it can procure assistance from other authorities and organisations in the event of undesirable incidents.

### 1.16.2 The role of the NCA

1.16.2.1 The NCA is responsible for ensuring that Norway has a comprehensive, public marine safety and emergency response system that will contribute to the development of clean and safe coastal and territorial waters, including responsibility for the state's response to marine incidents that might threaten safety at sea or be harmful to the environment. The NCA is also responsible for ensuring that private enterprises and municipalities take necessary action to prevent and limit the harmful effects of acute pollution.

1.16.2.2 Undesirable incidents that may constitute a threat to safety at sea or to the environment, shall primarily be handled by the party responsible. If the responsible party fails to take sufficient action, the incident shall be handled by the NCA's emergency response organisation.

1.16.2.3 Horten Vessel Traffic Service (Horten VTS) is the initial point of contact in the NCA's first-line emergency response organisation for the Oslofjord. Within its scope of action, the vessel traffic service shall combat undesirable incidents that might threaten safety at sea or be harmful to the environment by carrying out the following tasks, among others:

- When the situation precludes prior notification of the emergency response team on duty, take immediate physical action to prevent an undesirable incident at sea from escalating into a situation that threatens safety at sea and/or causes pollution.
- Have procedures in place to get an overview of relevant emergency response resources in its own area.

### 1.16.3 Ports of refuge and beaching sites<sup>27</sup>

1.16.3.1 The NCA has a list of pre-designated ports of refuge and beaching sites, and has prepared a separate procedure (*Prosedyre – Nødhavn og strandsetting* – in Norwegian only) for their use. The procedure describes how the NCA can intervene and take action in relation to Norwegian and foreign vessels in distress that constitute a threat to safety at sea or represent an environmental risk. The purpose of this procedure is to ensure that the decisions made and the actions taken by the NCA in collaboration with other authorities to make use of a port of refuge or beaching site, if applicable, are the most appropriate in any given situation. In the abovementioned procedure, a 'beaching site' is defined as a site where a ship can be beached if there is immediate danger that it will otherwise be totally wrecked or sink.

1.16.3.2 The role of the NCA in connection with undesirable incidents at sea is to supervise, monitor, advise the vessel's master and owner, and implement emergency response

---

<sup>27</sup> Source: [www.kystverket.no](http://www.kystverket.no)

actions to prevent acute pollution. If the situation is not handled in an adequate manner, the NCA will implement necessary actions on behalf of the owner. The procedure stresses that in a situation of distress requiring immediate and resolute action, the pilot and traffic control service will implement actions to prevent and reduce risk. The emergency response department shall be notified as soon as possible and informed of the actions that have been implemented and, if necessary, it will take over the coordination of the response action. The abovementioned procedure does not apply to situations being handled by the joint rescue coordination centres and that involve a threat to human life and health.

- 1.16.3.3 As mentioned above, Grisebukta bay outside Fagerstrand is a designated beaching site and the site has been assessed for the purpose with a view to vulnerable environments, protection areas and suitability for oil-spill response action, as well as navigational access.

## **1.17 Pilotage services<sup>28</sup>**

### **1.17.1 Pilotage services in general**

- 1.17.1.1 The NCA is responsible for Norway's pilotage services. The main objective of the pilotage services is to contribute to the safety of traffic at sea and protect the environment by supplementing vessels' crews with necessary fairway knowledge. By pilotage is meant guidance relating to vessels' navigation and manoeuvring. A state pilot is employed by the state. A pilot is a person with a pilot's certificate pursuant to the Norwegian Pilotage Act. The Act does not in any way change the rules relating to the responsibility of the ship's master or of the officer of the watch as the master's deputy. The pilot is responsible for piloting the vessel. The ship's master or officer of the watch can leave it to the pilot to issue directives on behalf of the vessel relating to the vessel's propulsion, navigation and manoeuvring.
- 1.17.1.2 Pilots have a background as vessel masters or chief mates before they are recruited by the NCA. In the NCA they undergo internal training for a period of approximately 15 months, in addition to some external training. The pilots must pass an exam before they are certified as state pilots, and they must have some experience of smaller vessels before they are allowed to pilot larger vessels. In addition to state pilots, the service includes pilot procurement and transport services (transport of pilots by pilot boat or helicopter).
- 1.17.1.3 Pilotage services are regulated by the Norwegian Pilotage Act<sup>29</sup>, which, among other things, contains provisions on compulsory pilotage, how pilotage should be carried out, pilotage preparedness and pilotage charges. In addition to the Act, there are a number of regulations (A total of 18 regulations as of January 2009) that provide more detailed instructions on how pilotage services are to be carried out. Among them are the Rest time Regulations<sup>30</sup>, which mainly specify that pilots shall have a minimum of twelve hours' rest every day, and that the hours of rest must not be split between more than two periods.

---

<sup>28</sup> Source: [www.kystverket.no](http://www.kystverket.no)

<sup>29</sup> Act no. 59 of 16 June 1989 relating to pilotage services etc.

<sup>30</sup> FOR 1991-12-10 Regulation of 10 December 1991 relating to pilots' off-duty periods for safety reasons.

- 1.17.1.4 The NCA has prepared a set of service instructions for state pilots<sup>31</sup>. Section 4 imposes an obligation on pilots to decline to take assignments under certain conditions:

*‘A state pilot is obliged to inform his superiors of any circumstances that could impede the safe execution of a pilotage assignment, including circumstances relating to the pilot’s own competence, illness or tiredness, and circumstances relating to the vessel and crew etc. A state pilot shall not accept pilotage assignments that he/she does not regard him/herself as competent for or capable of carrying out.’*

- 1.17.1.5 Pilots’ working hours arrangements are also regulated by a special collective agreement<sup>32</sup> entered into between the NCA and the Norwegian Pilots’ Union. The current agreement was signed on 30 October 2008 and is valid until 31 October 2010. The pilots in the Oslofjord work a rota whereby they are on duty for stretches of one or two weeks. Free periods are usually taken out in whole weeks. During the pilots’ on-duty periods, they are at the disposal of the NCA 24 hours a day, but they can work maximum 12 hours per day.
- 1.17.1.6 A supplement of NOK 100 per hour is paid for ‘active bridge service’ during the hours between 06.00 and 20.00, and a supplement of NOK 150 per hour is paid for ‘active bridge service’ during the hours between 20.00 and 06.00. By ‘active bridge service’ is meant the hours that the pilot actually spends piloting.
- 1.17.1.7 In Norway, requests for pilots are made through a pilot dispatch centre. There are three of these – at Horten, Kvitsøy and Lødingen. Pilotage in the Oslofjord is ordered from the Horten pilot dispatch centre, which will distribute the assignments between the pilots who are on duty at any time. If the traffic is heavy, the pilot dispatch centre will call in pilots to work overtime, or, alternatively, exempt vessels from the provisions on compulsory pilotage and let them sail without a pilot. Such exemption shall only be granted after an evaluation of the vessel and crew, the waters through which the vessel will be sailing and any other relevant factors. Approximately 46,000 pilotage assignments are carried out annually in Norway.
- 1.17.1.8 The NCA has laid down instructions for the pilot dispatch services (see Annex). The instructions state that ‘the primary task of the pilot dispatch service is to ensure efficient, flexible and rational utilisation of the pilot corps within the framework of applicable legislation, collective agreements and other provisions.’<sup>33</sup> The staff at the pilot dispatch centres have a wide range of tasks, including obtaining relevant information about vessels and pilotage assignments, and conveying this information to the pilots when assigning them to a vessel. The instructions also require the staff to ‘keep an overview of the hours worked by each individual pilot’ (section 3j).

---

<sup>31</sup> *Tjenesteinstruks for statsloser* (‘Service instructions for state pilots’ - in Norwegian only), annex E.

<sup>32</sup> *Særavtale for arbeidstakere som gjør tjeneste som statsloser og statslosaspiranter i Kystverket* (‘Special agreement for employees serving as state pilots and state pilot trainees’ – in Norwegian only, see Annex H.

<sup>33</sup> Section 7.4 of *Instruks for losformidlingstjenesten* (‘Instructions for the pilot ordering service’ - in Norwegian only), Doc. no. MT-HB-7.4, 09.01.2006, NCA, see Annex I.



1.17.1.9 For various reasons, Hvasser pilot station was low on manpower during the week in question. There are usually between five and seven pilots on duty, while, in this case, there were only four.

### 1.17.2 The pilotage assignment under consideration

1.17.2.1 The *Crete Cement* had ordered a pilot for the voyage from Færder to Slemmestad through the pilot ordering centre in Horten in accordance with the NCA's provisions on ordering pilots. Both the pilot and crew on the *Crete Cement* thought that this could be regarded as a routine assignment – a voyage that the vessel, crew and pilot had made many times before without any particular problems or challenges having been reported.

### 1.17.3 The pilot

1.17.3.1 The pilot was 61 years old, educated as navigator in 1967-1970 and certified as pilot for the Oslofjord in 1980. He had passed the site at which the vessel ran aground between two thousand and three thousand times, and he must therefore be deemed to have had a great deal of experience.

1.17.3.2 The pilot started his period of duty on 13 November. He had been assigned overtime on the day before going on duty. During the period up to and including his piloting of the *Crete Cement* he had worked on the following consecutive assignments:

<b>Date:</b>	<b>Left home</b>	<b>Started bridge watch</b>	<b>Finished bridge watch</b>	<b>Arrived home</b>
12 Nov. 2008	02.19	03.54	06.25	07.39
13 Nov. 2008	12.30	15.10	18.30	22.14
		19.54	21.20	
14 Nov. 2008	04.20	05.08	06.30	08.00
14.-15 Nov. 08	22.40	23.40	05.05	12.30
15 Nov. 2008	15.20	16.35	18.20	18.40
16 Nov. 2008	04.18	05.36	07.25	11.47
		08.25	10.40	
16 Nov. 2008	21.44	22.50	03.00	11.30
17-18 Nov. 2008	15.59	17.30	20.45	08.00
		03.30	06.40	
18 Nov. 2008	13.00	14.35	16.20	17.00
19 Nov. 2008	01.13	02.40	06.40	19.52

Figure 22: Overview of the pilot's work periods.

In addition to the hours spent on the bridge, he spent time travelling to and from the pilotage assignment. Travel time from his home to the pilotage assignments varied from approximately 50 minutes to approximately 3½ hours. The time between leaving a pilotage assignment and arriving home varied from approximately 20 minutes to 8½ hours. In addition to travel time and the time spent on active bridge watch, there was administrative work, preparation for piloting and any waiting time. The hours between assignments the pilot mainly spent resting.

1.17.3.3 All pilots past the age of 50 undergo an annual medical examination by a seamen's doctor pursuant to *Forskrift om legeundersøkelse for statsloser og losaspiranter*<sup>34</sup> ('Regulations relating to medical examination of state pilots and trainee pilots' – in Norwegian only) The pilot had attended his most recent medical examination on 25 February 2008. Shortly after the grounding incident, the pilot underwent a number of tests at the Hospital of Vestfold-Tønsberg in order to determine, if possible, whether any health related issues could have had any impact on the situation that occurred. There were no indications that this had been the case.

## 1.18 Navigational aids and chart corrections

1.18.1 The inner part of the Oslofjord has seen extensive new navigational aids and deepening of the waters in recent years. Among other things, the 'old' Digerudgrunnen lighthouse has been demolished. The demolition work started on 16 June 2008. The lighthouse was replaced by two new lighthouses – one to the south and one to the north of where the old lighthouse had stood. The building work started on 24 September 2007 and was completed on 25 June 2008. Adjustment and testing of the lighthouse light sectors were carried out on 28 October 2008.

1.18.2 The chart in figure 23 below, shows navigational aids in the area roughly as they were in the morning of 19 November 2008. You can see the two newly constructed lighthouses at Digerud and new lighthouses southwest of Aspond Island and off Ristodden. The old lighthouse at Digerud is still marked on the chart, between the two new ones, but it had been demolished when the vessel ran aground. Hence there was no light emanating from this position.

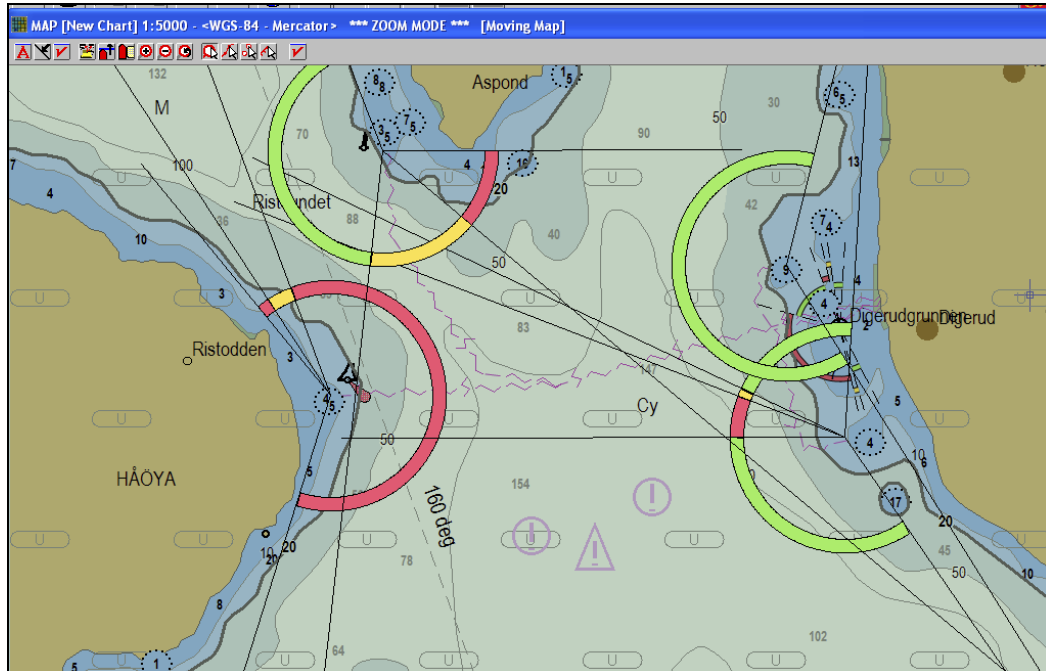

Figure 23: Overview of new navigational aids in the area. Source: The Norwegian Coastal Administration).

<sup>34</sup> FOR 1974-06-28 no. 03: *Forskrifter om legeundersøkelse av losere og losaspiranter* ('Regulations relating to medical examination of state pilots and trainee pilots' – in Norwegian only)

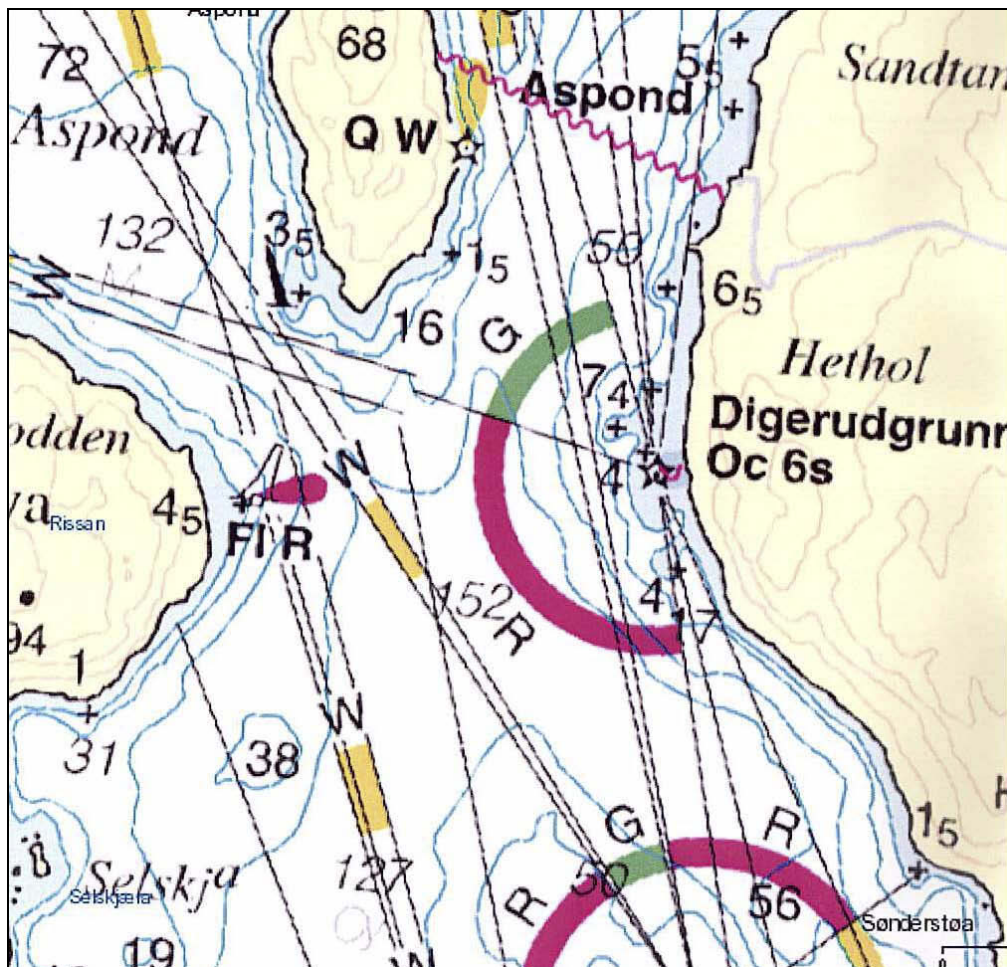

Figure 24: Chart of the same waters before the construction work started.

- 1.18.3 When the NCA starts work on lighthouses and other important navigational aids, they send out notices to the Norwegian Mapping Authority (NMA) – Hydrographic Service (NHS), which will convey this information to the users through Norwegian Notices to Mariners (EfS). The corrections are classified as temporary (T) or provisional (P) corrections. The NMA/NHS draw the following distinction between the two types of corrections:<sup>35</sup>

*Temporary changes to lighthouses and lanterns, and lighthouses and navigational aids that are temporarily not working. Notices are also provided about shooting exercises, orders and directives relating to sailing in particular areas, seismic surveys, rig moves etc. ('T' Notices).*

*Provisional notices relating to planned changes to lighthouses and navigational aids etc. ('P' Notices).*

EfS no. 20 – 2007 contained a 'T' correction (number 1214) relating to future construction work in the Oslofjord; it did not however name each individual project.

EfS no. 1 – 2008 described the details of the development project in a 'P' correction (number 71). The correction described the main features of the development project and all objects to be changed were named and their position stated.

<sup>35</sup> Source: *Den Norske Los bind 1, Alminnelige opplysninger* ('The Norwegian Pilot – volume 1 General Information' – in Norwegian only)

Further ‘P’ corrections containing more detailed information were sent out in EfS no’s 10, 13 and 24 – 2008.

- 1.18.4 There is no common international standard relating to whether or not ‘P’ and ‘T’ corrections should be included in the corrections made to electronic charts. As evidenced by Annex E, Norway is among the states that do not include ‘P’ and ‘T’ corrections in the corrections made to electronic charts, while other states have chosen different solutions. There are several reasons why these corrections are not included. When the current electronic chart system was designed and the specifications prepared, the possibility of transferring large amounts of data was very limited. This meant that the national mapping authorities had to make some kind of selection concerning the information to be included in the corrections.
- 1.18.5 When asked, the NMA/NHS has informed us that the most important reasons why ‘T’ and ‘P’ corrections are not presented in electronic charts are data limitations in the S-57 format<sup>36</sup> and the fact that there are no international standards for presenting this type of information in electronic charts.

## 1.19 Horten VTS

- 1.19.1 Voyages through the areas covered by Horten VTS (and other vessel traffic services) are regulated by separate regulations<sup>37</sup>. The regulations describe relations between the vessel and the VTS and instruct vessels to obtain permission before starting the voyage and to listen to the VTS’s work channel, among other things. A VTS primarily provides three types of services:

### 1. Traffic regulation services

This includes providing vessels with sailing permission in accordance with applicable sailing regulations in the area. Vessels that are required to have a pilot on board when sailing through the inner part of the Oslofjord are first issued with a clearance to proceed to the pilot embarkation place when passing into the VTS area at approx 58°58’N. When the pilot is embarked, clearance is given to continue up the fjord to Tofteholmen. At Tofteholmen clearance is given for the voyage through the Drøbaksundet narrows to the area for which Oslo VTS is responsible.

### 2. Information services

### 3. Navigation guidance services

- 1.19.2 During the *Crete Cement*’s voyage up the Oslofjord, a first clearance to sail to the pilot embarkation area was issued by Horten VTS when the vessel entered the area of responsibility. The pilot came on board at the pilot embarkation area off Store Færder at 02.40, and a clearance to sail northwards through the Oslofjord was given. On passing Tofteholmen at approximately 04.15, the vessel was issued with a new clearance to sail northwards through Drøbaksundet’s eastern navigation channel. This meant that the vessel was to sail east of Askholmene and then between Fagerstrand and the islands of Aspond, Gråøya and Søre Langåra. It is not the task

<sup>36</sup> International Hydrographic Organization (IHO) Transfer Standard for Digital Hydrographic Data.

<sup>37</sup> FOR 11.12.98 no. 03: *Forskrift om sjøtrafikk i bestemte farvann* (‘Regulations relating to marine traffic in certain navigation channels – in Norwegian only)

of the VTS to interfere directly in a vessel's voyage, particularly not in narrow waters.

## 1.20 Other information

### 1.20.1 Sleepiness

1.20.1.1 There has been a lot of research on various shift schedules and their effects in the different sectors of the transport industry. The research has demonstrated that sleepiness has been a contributory factor to many accidents and incidents in the transport sector. The fact that this accident took place early in the morning means that the AIBN have to consider whether sleepiness was a contributory factor to the *Crete Cement* running aground. For this purpose, the AIBN has been assisted by Professor Bjørn Bjorvatn of the University of Bergen, who is also head of Norway's National Competence Centre for Sleep Disorders, to determine whether sleepiness could have been a contributory factor (see Annex F).

1.20.1.2 When interviewed, the pilot stated that, when the pilot ordering centre called him at 01.00, he felt capable of taking on the assignment even though he was tired after a demanding duty period. He saw nothing extraordinary in the situation and felt that he had been equally tired on other occasions. He had slept for between 3.5 and 4 hours when he was woken up. Sleepiness or work load was not mentioned during the telephone conversation between the pilot and the pilot ordering centre.

1.20.1.3 None of the crew on the *Crete Cement* have mentioned that they were particularly tired or sleepy during the voyage towards Slemmestad; there had been no excessive work load prior to the grounding.

### 1.20.2 Resources on the bridge

1.20.2.1 The requirements for manning of the bridge are described in the STCW Convention<sup>38</sup> chapters II and VIII. The owner's plans for manning the bridge are described in the safety management system and reflect those requirements.

### 1.20.3 Cooperation on the bridge

1.20.3.1 The officer of the watch, lookout and pilot have all stated that they were in no doubt about their respective tasks during the voyage towards Slemmestad. They saw no reason to discuss how the tasks were allocated, since they felt that it was self-evident during a voyage of this type.

1.20.3.2 Both the officer of the watch and the pilot were clear about the vessel's route when sailing towards Slemmestad. It was marked on both paper charts and electronic charts and was mainly in accordance with the pilot's plan. They saw no reason to discuss this plan.

---

<sup>38</sup> International Convention on Standards of Training, Certification and Watchkeeping for Seafarers, IMO 1978, (as revised).

#### 1.20.4 Other investigations

- 1.20.4.1 The bulk carrier *Federal Kivalina* ran aground off Årsundøya Island east of Kristiansund on 6 October 2008. The investigation following the accident showed, among other things, that the manning of the bridge was not functioning during the period before the vessel ran aground. The pilot and the ship's crew did not work as a team, and the ship's crew did not know where to sail. The AIBN's report was submitted in January 2010. Among other things, the report recommended that the NCA '*consider changes in the training of pilots and procedures, along with other measures, so that the pilots can more efficiently be part of a well-functioning bridge team*'<sup>39</sup>.

---

<sup>39</sup> The report is available at [www.aibn.no](http://www.aibn.no).

## 2. ANALYSIS

### 2.1 Introduction

- 2.1.1 Many parties played a role in this accident. Norwegian state agencies such as the NCA, the NMA/NHS, the Police and the NMD are mentioned in this report to varying degrees. The Bahamas Maritime Authority is the supervisory authority for the flag state Bahamas. In addition to the above, private companies such as Kristian Gerhard Jebsen Skipsrederi AS, KGJS Cement and Bureau Veritas also play a role. Our investigation has mainly been limited to those finds that are directly relevant to the specific accident under investigation.
- 2.1.2 The reason why the AIBN has chosen to consider certain factors surrounding the action following the grounding is that the AIBN, pursuant to Odelsting Proposition no. 78 (2003-2004)<sup>40</sup>, is assigned the task of considering such factors if they have been decisive for the outcome, which is believed to be the case here. The fact that the vessel was beached meant that the subsequent action was of a totally different nature from what it would have been had the vessel sunk. Our considerations will be limited to this topic and not include any details relating to the rescue, salvage or oil-spill response actions.
- 2.1.3 In this analysis, the AIBN has focused on mapping contributory factors and barriers that would or could have prevented the accident had they been intact. Our mapping and evaluation was carried out in accordance with the principles set out in Hollnagel's 'Barriers and accident prevention'.<sup>41</sup>

### 2.2 Bridge resource management

#### 2.2.1 Manning of the bridge

- 2.2.1.1 In essence, the manning of the bridge during the voyage up the Oslofjord met the requirements of the STCW Convention<sup>42</sup> and national legislation both in the Bahamas and in Norway. It was sufficient to ensure a safe voyage under normal circumstances in most waters and during the greater part of the voyage from Færder to Slemmestad.
- 2.2.1.2 The STCW Convention Section A-VIII/2 sets out guidelines for watch-keeping on board. These guidelines are mainly reflected in the owner's safety system and our analysis below is therefore mainly based on that safety system.
- 2.2.1.3 The owner's safety system<sup>43</sup> lists circumstances in which the master must 'maximise his direct presence on the bridge'. The listed circumstances include that the master should be present on the bridge when navigating in closed, narrow navigation channels, and when the vessel is under pilotage. Whether a navigation

---

<sup>40</sup> Odelsting Proposition no. 78 (2003-2004) On the Act relating to the amendment of Act no. 39 of 24 June relating to shipping (the Norwegian Maritime Code) and certain other Acts. (Investigation of marine accidents.)

<sup>41</sup> Hollnagel, Erik (2004) *Barriers and Accident Prevention*, Aldershot, UK. Ashgate Publishing Co.

<sup>42</sup> International Convention on Standards of Training, Certification and Watchkeeping for Seafarers, IMO 1978, (as revised).

<sup>43</sup> KGJS Shipboard Main Manual for Cement Vessels, procedure 19.02.

channel is to be regarded as closed and narrow will depend on the size of the vessel, but, for most vessels, the description would cover the relevant northbound navigation channel from Drøbak past Fagerstrand. In the AIBN's opinion, this was the case for the *Crete Cement* in the situation under consideration.

2.2.1.4 A matter that is not mentioned in the owner's safety management system is whether or not the master should be present on the bridge during periods when the officer of the watch must attend to other tasks in addition to navigation. In our case, the officer of the watch had to prepare and organise the vessel's arrival and moorings at Slemmestad. Hence his full attention was not on the navigation as he had recently been engaged in other necessary tasks. This meant that one of the barriers designed to ensure an adequate level of safety in this relatively narrow channel was weakened. During the critical period when passing Digerud, and the change of course should have been initiated, none of the vessel's crew kept a sufficient navigation watch. Had the master arrived on the bridge only a few minutes sooner, while the officer of the watch was busy organising the port call at Slemmestad, this barrier would probably have been intact.

## 2.2.2 Use of bridge resources

2.2.2.1 During the voyage under consideration, the following persons were present on the bridge: the officer of the watch, the pilot and the lookout. The fact that it was dark made it difficult for the lookout to assess the distance by eyesight, particularly to a shore that was unlit. The lookout was asked to stay close to the steering console in order to change from autopilot to manual steering if necessary. If the only task of the lookout had been to look out, it is possible that he would have discovered the hazard sooner. This cannot be confirmed or precluded.

2.2.2.2 During the voyage up the Oslofjord, communication between the pilot and officer of the watch was limited to practical matters about coffee, lighting the deck lights etc. Details relating to the voyage were not discussed. All parties involved had completed this voyage many times, so any further exchange of information was regarded as superfluous. There was no doubt among those involved about which route to take, and it was also clear at what points the course would have to be changed. These were marked as waypoints on the charts and in the GPS.

2.2.2.3 In the AIBN's opinion, it is regrettable that there was so little exchange of information. Lack of communication procedures on the bridge increase the threshold for when those involved raise questions relating to the voyage and, if applicable, notify of circumstances that seem to deviate from a normal voyage. Such active teamwork is important and, in this connection, we refer to the AIBN's Report after the grounding of the *Federal Kivalina* off the Årsundøya Island, submitted in January 2010. Among other things, the report recommended that the NCA 'consider the introduction of changes to training programmes, procedures and other measures to achieve better incorporation of the pilot into a well-functioning bridge team'<sup>44</sup>.

2.2.2.4 Even if the limited communication cannot be said to have had any decisive effect on the accident, a more well-functioning bridge team would have strengthened the

---

<sup>44</sup> The report is available at [www.aibn.no](http://www.aibn.no).



barrier that is constituted by the ship crew controlling and monitoring the navigation.

- 2.2.2.5 On the bridge, the climate of cooperation between those involved will largely be decided by the most senior person in authority. Such authority may be of a formal or informal nature, though in most cases the two will be related. In our particular case, it is debatable who was formally in the most senior position of authority – the pilot as representative of the Norwegian authorities, or the chief mate, who, in his capacity as officer of the watch, exercises the master's authority over the vessel. The informal authority is easier to describe. The pilot is regarded as having greater authority than the officer of the watch in terms of position, age and experience, and in accordance with accepted international practice. This means that the pilot has a special responsibility for fostering a climate in which the resources on the bridge are used in an optimum manner. There is no information to indicate that the climate of cooperation was unfavourable or that it had any impact on the course of events. The lookout and officer of the watch seem to have reacted as soon as they became aware of the danger to the vessel, without any fear of disturbing or being a nuisance to someone in a more senior position of authority.
- 2.2.2.6 There was little communication between the officer on duty and the pilot during the voyage up the Oslofjord. Nevertheless, there are no indications that any of those involved were in any doubt about how the voyage should proceed. Courses had been plotted on two sets of charts and on a route plan in the electronic chart system, and they were in compliance with the pilot's planned voyage. Everything took its normal course up until the time of the incident, and there was no confusion about who was responsible for what. Those involved had participated in the same voyage previously.
- 2.2.2.7 The officer of the watch monitored the voyage until he became involved in waking up officers and crew and organising the port call at Slemmestad. There are no indications that he, to any notable degree, was engaged in activities that were unrelated to his duties as the officer of the watch, but in this particular situation, the timing of these duties was unfortunate.

## 2.3 Sleepiness

- 2.3.1 The *Crete Cement* had completed loading at Brevik and the loading equipment was disconnected at 18.40. The vessel lay waiting without the crew being engaged in any particular activities until it departed at 23.15. There is nothing to indicate that sleepiness, to any notable degree, had any impact on the crew's judgement and actions on board the *Crete Cement*. This will therefore not be subject to any further consideration.
- 2.3.2 The pilot had started his period of duty on 13 November, seven days before being assigned to pilot the *Crete Cement*. In addition to the above, he had completed an overtime assignment the day before going on duty on 13 November. A review of the pilot's assignments during his duty period confirms that his work load was in accordance with the Pilotage Act and Rest Regulations, which provide for a minimum of twelve hours' rest every day and that the hours of rest must not be split between more than two periods.

- 2.3.3 Even though the pilot's work load was in accordance with the provisions of the Pilotage Act and the Rest Regulations, the AIBN has analysed the pilot's duty period with a view to sleepiness. Two questions stand out as pertinent to answer in order to understand what contributed to the vessel running aground. The first question is whether sleepiness felt by the pilot contributed to the change of course of the *Crete Cement* after passing Southern Digerud lighthouse between 90 and 100 seconds behind schedule. The second question is whether the pilot's work period and related opportunities for rest and sleep could have caused increased sleepiness.
- 2.3.4 The change of course was initiated after the chief mate called the pilot who jumped and started to change the course using the autopilot until the chief mate ordered the switch to manual steering. During the 90-100 seconds that passed between the time when the course should have been changed and until the lookout reacted, the pilot was standing in an upright position facing the direction in which the vessel was heading. The pilot has extensive experience of piloting the navigation channel where the vessel ran aground, so the fact that the pilot did not change course in time, cannot be explained by lack of experience or lack of planning. Courses had been marked as waypoints on the charts and the route plan had been plotted in the electronic chart system. Unlike the chief mate, the pilot was not engaged in other tasks at the time.
- 2.3.5 The fact that the pilot jumped when the chief mate called to him shows that, for some reason or other, the pilot's attention was not focused on the task of navigation. This suggests that his attention was probably reduced due to sleepiness for some part of this 90-100 seconds' period. The AIBN finds support for this view in Professor Bjorvatn's assessment that insufficient sleep and increased sleepiness can cause one to fall asleep, even in a standing position and with one's eyes open.
- 2.3.6 The last point in time before running aground at which we can say with certainty that the pilot was focused on his task, was during the change of course on passing Storegrunnen lighthouse at 06.26. This was approximately five minutes before the vessel ran aground.
- 2.3.7 Professor Bjorvatn's bases his view of the pilot's probable increased sleepiness on the fact that, prior to the incident, the pilot had not slept much during his duty period. It is emphasised that the periods in which he had not been on active duty had been of varying duration and that the pilot had to sleep at times of day when it is often difficult to fall asleep. As an example, we can mention the so-called 'sleep forbidden zone', which for most people is between 20.00 and 22.00. It is also emphasised that the accident occurred during a period when people become more sleepy due to their diurnal rhythm and which research has shown accidents are more likely to occur, namely, at around 05.00 and one or two hours thereafter. Insufficient sleep during the preceding days will tend to increase a person's sleepiness.
- 2.3.8 Based on the above, the AIBN believes that there is a high probability that the pilot's sleepiness at the time of the accident increased and it may therefore have been a contributory factor to the belated change of course, which did not take place until the pilot was notified by the chief mate.

- 2.3.9 The pilot's active duty periods during the days preceding the assignment had been irregular and followed close on each other. The pilot had had little time to sleep and had to sleep during periods of the day when it is difficult to fall asleep. Night work, which was what the pilot had been doing, was not followed by sufficient opportunities for restitution. That would increase the probability of sleep deficit and hence the probability of sleepiness and reduced ability to perform.
- 2.3.10 The AIBN acknowledges there are individual differences between how people handle shift work in general, night work in particular and reduced opportunities to sleep. However, there is nothing to suggest that the pilot had any particular problems in this respect. He had not previously experienced any particular problems.
- 2.3.11 The NCA's service instructions for state pilots section 4 require pilots to decline a pilotage assignment, among other things if they feel too tired to carry out the assignment in a safe manner. The AIBN believes it may be difficult for a pilot to decide when he/she is too tired or sleepy to decline a pilotage assignment. Many people will also compensate for sleepiness by taking caffeine. However, this is no compensation for the importance of good sleep and restitution. Other factors that may have contributed to making it difficult for pilots to decline a pilotage assignment are a shortage of manpower and an unwillingness to burden their colleagues. Hvasser pilot station had reduced manpower during the duty week in question, which imposed a greater load on those who remained on duty. In addition to the above, there is a financial incitement in the special collective agreement, which provides for extra compensation for every hour during which the pilot is on active bridge service and additional payment for night-time bridge service<sup>45</sup>.
- 2.3.12 The AIBN believes that the pilot's increased sleepiness shows that the Pilotage Act, Rest Regulations and the pilots' special agreement are not sufficiently based on research relating to people's needs for sleep and rest and how reduced sleep and rest can contribute to reducing the ability to perform. The AIBN realises that much of the research relating to shift work, sleepiness and performance has little focus on the type of stand-by shifts comprised by the working hours arrangements for state pilots. The AIBN believes that the NCA should evaluate the pilots' working hours arrangements with a view to identifying any negative consequences they may have in terms of opportunities for sleep and rest, and implement necessary measures.

## 2.4 Charts and navigation

### 2.4.1 General

The *Crete Cement* was well-equipped with charts. On board, there were paper versions of British Admiralty Charts, which served as the vessels official charts and were kept updated. There were also some of the NHS's paper charts to varying scales (1:50000 and 1:25000) on board, and a non-authorized electronic chart system. The vessel's planned route was plotted on all three versions of the charts, and it was mainly in accordance with the pilot's planned route. The route planning

---

<sup>45</sup> *Særavtale for arbeidstakere som gjør tjeneste som statsloser og statslospiranter i Kystverket* ('Special agreement for employees serving as state pilots and state pilot trainees' – in Norwegian only), see Annex H.

and other preparations did not impede monitoring by the vessel's crew of the pilot's voyage up the Oslofjord.

## 2.4.2 Paper charts

2.4.2.1 The *Crete Cement* used nautical charts from the British Admiralty (BA) as official navigation charts. In general, 'T' and 'P' corrections along the Norwegian coast are not included on these charts. In this case, British Admiralty had published a general correction stating that construction work was in progress on various fixed navigational installations in the Oslofjord. Combined with the fact that the vessel's crew had passed through this area several times lately, this meant that the officer of the watch was aware of the newly installed lighthouses at Digerud. The accurate positions of those lighthouses were not plotted on the BA charts and he was therefore unable to make full use of them when navigating.

2.4.2.2 When printed, the Norwegian paper charts on board had been corrected up to and including EfS 16/2006. EfSs had been subscribed to since July 2007. This meant that there was just over one year of corrections that the crew on the *Crete Cement* did not have access to. Because of this, they would never be able to fully update the Norwegian charts. This makes it easier to understand why subsequent corrections were not completely implemented either.

2.4.2.3 It is extremely unfortunate that the level of detail of the corrections to the paper charts depends on the choice of supplier of charts. In our case, accurate information about the location of the new lanterns could have been acquired by means of 'T' and 'P' corrections if Norwegian charts were being used, whereas this information would not readily be available if BA charts or other charts were used. It is also quite understandable that the BA cannot issue all 'T' and 'P' corrections that are produced for all the stretches of water covered by them. The volume of corrections would be unmanageable for navigators.

## 2.4.3 Electronic charts

2.4.3.1 The *Crete Cement* was using an unauthorised electronic chart system of the type C-Map CM93 Professional. In principle, authorised chart systems that are regularly updated with corrections provide better and more reliable information than unauthorised systems. In our case, it made no difference. Even with an electronic chart system authorised to the ECDIS standard the new navigational aids in these navigation channels would not have been shown.

2.4.3.2 If the electronic chart system had provided accurate information about the new navigational aids, it would have been easier for the officer of the watch to keep updated about the vessel's position and course, especially since he was occupied with other tasks as well as paying attention to the voyage. There are, however, no grounds for claiming that the lack of updates to the electronic charts was among the causes of the accident; however, it must be deemed to constitute a weakening of an important barrier.

2.4.3.3 The overview of how various countries handle 'T' and 'P' corrections in Annex E demonstrates that it is very difficult for seafarers to know whether the electronic

charts they have on board, authorised or not, include information about these corrections.

## 2.5 Steering the vessel

During the inbound voyage to Slemmestad the vessel was steered by using the autopilot. In the AIBN's opinion autopilot use in narrow waters should be limited. As a main rule hand steering should be used. This is reflected in the owner and vessels' safety management system.

## 2.6 Watertight integrity

2.6.1 The watertight sections and stability were satisfactory provided that the vessel was being operated with all the watertight hatches and openings properly closed. In the AIBN's opinion, the *Crete Cement* satisfied the formal design requirements relating to these areas.

2.6.2 As part of the conversion to a cement carrier, the inner bottom was moved further into the vessel over large areas with the construction of the pipe trunk and blow-tank tunnel. As a result of the conversion, the new inner bottom was the roof of the blow-tank tunnel. This meant the acceptance of large areas being flooded in the event of minor damage to the hull, for example, in the bow-thruster room.

2.6.3 A watertight bulkhead at the aft end of the bow-thruster room would have prevented flooding in the pipe trunk and blow-tank tunnel, and reduced the probability of extensive flooding damage following damage to the forward hull section. The regulations permit designs without this watertight section, but this makes it even more important that the other watertight sections are intact and functioning.

2.6.4 Those parts of the bilge and ballast system that lie between blow-tank three and the engine room are only accessible from the engine room via the manhole in the engine room bulkhead (a watertight bulkhead). The arrangement is considered to be within class rules, international and statutory regulations. In the opinion of the AIBN, it is regrettable that parts of the vessel's watertight sections had to be opened in order to gain access to equipment that required regular maintenance and control. This meant that, periodically, the vessel's watertight integrity was not satisfactory, and involved a risk of the crew letting the manhole cover remain open over lengthy periods if a need for regular inspections and maintenance of the area in question was expected. The shipping company has not adopted solutions whereby the watertight integrity is maintained in day-to-day operations. Nor has this weakness been uncovered by the classification society.

2.6.5 The sister ship, the *Cyprus Cement*, has a similar design to the *Crete Cement*. The AIBN therefore believes that there may be similar problems relating to that ship and possibly to other vessels with a similar design.

## 2.7 Beaching

- 2.7.1 The preparatory works relating to amendments to the Maritime Act<sup>46</sup> allow the AIBN to investigate the manner in which the rescue and emergency response operations are organised and carried out where this has proved decisive for the outcome of the accident. In this case, the AIBN is of the opinion that the fact that the *Crete Cement* was beached had a decisive impact on the outcome of the accident.
- 2.7.2 The pilot was familiar with the NCA's plans for places of refuge and beaching sites, and this information was confirmed by Horten VTS. The fact that these plans were in place contributed to a speedy decision to beach the vessel. As the decision to beach the vessel was being taken, the pilot and the master were uncertain as to whether the *Crete Cement* would remain afloat or sink, given the damage that the ship had sustained. They were unaware of the scope of the damage, or the extent to which the watertight sections remained intact. Calculations carried out by DNV ERS show that the vessel would have lost engine power relatively quickly and subsequently sunk. In this situation, it was decisive for the subsequent efforts that the vessel was beached. If the *Crete Cement* had sunk in deep water in the middle of the fjord, the oil-spill response action would have been of a different nature, and any salvaging of the vessel would have been extremely difficult and demanding in terms of resources.
- 2.7.3 After the beaching, the rescue, salvage and oil-spill response actions were conducted with no injuries to personnel, minimum damage to the environment and no notable problems relating to cooperation between the various players. One detail that did emerge from the interviews with those involved at Fagerstrand was the uncertainty experienced by some individuals as to who was actually leading the local operations between the time that RCC-S terminated its response efforts at 08.37 and the NCA's representative on board the *KV Nornen* arrived at approximately 15.00. The pilot was in many ways leading the operations locally, but this was not formalized. In the case under investigation, it was not found that any part of the response action was impeded by this uncertainty. Our investigation was therefore delimited so that we did not look at these aspects in any detail; they were deemed to lie outside the AIBN's frames of reference since they did not have any decisive impact on the situation.

---

<sup>46</sup> Odelsting Proposition no. 78 (2003-2004) on the //Act relating to the amendment of Act no. 39 of 24 June 1994 relating to shipping (the Norwegian Maritime Code) and certain other acts, section 9.4.5.

### **3. CONCLUSIONS**

#### **3.1 Contributory factors and barriers**

- 3.1.1 When navigating the narrows north of Drøbak, the crew should have been reinforced with an additional navigator, preferably the master. The need for this was even more pressing as the officer of the watch had to attend to other tasks in addition to navigation. On this point, KGJS should provide further clarification in its safety management system, and a safety recommendation is submitted relating to this matter.
- 3.1.2 In the AIBN's opinion, such limited communication on the bridge as in our case can sometimes have unfortunate consequences. A safety recommendation (MARINE no. 2010/04T) has already been addressed to the NCA in connection with the *Federal Kivalina's* grounding. Hence no new safety recommendation is submitted on this point.
- 3.1.3 The pilot had a strenuous duty period during the last week before the grounding. The AIBN believes that the high probability of increased sleepiness on the pilot's part shows that the Pilotage Act, Rest Regulations and the pilots' special agreement are not sufficiently based on research relating to people's needs for sleep and rest and how reduced sleep and rest can contribute to reducing the ability to perform. The NCA should evaluate the current working hours arrangements and implement corrective actions if appropriate. A safety recommendation is submitted to the Norwegian Coastal Administration on this point.
- 3.1.4 Even if the vessel had had an approved electronic chart system with updated charts, it would not have had information about the new navigational aids, since these had only been published as temporary ('T') and provisional ('P') corrections at the time. There are no international standards for the publication of such corrections. However, the situation was unfortunate, and a safety recommendation to the Norwegian Mapping Authority – Norwegian Hydrographic Service is submitted on this point.

#### **3.2 Factors with a bearing on the consequences of the grounding**

- 3.2.1 In an area aft of blow-tank 3, the *Crete Cement* had some parts of the bilge and ballast system only available through a manhole in the engine room bulkhead. The arrangement is considered to be within class rules, international and statutory regulations. The crew often required access to this area, and the vessel's watertight integrity is not intact when the manhole is opened. This is an unfortunate design that should be avoided in new builds in the future, alternatively that compensatory measures of a physical, technical or administrative nature or any combination of these are demanded. This operational issue should be taken into account when construction drawings of watertight bulkheads are examined. A safety recommendation to the Bureau Veritas is submitted on this point.
- 3.2.2 For existing vessels, it may be impossible or difficult to avoid having to pass through the engine room bulkhead and other watertight bulkheads to gain access to the ballast and bilge system or loading/discharge equipment. Where this is the case,

compensatory measures should be implemented, of a physical, technical or administrative nature or any combination of these. A safety recommendation to KGJS is submitted on this point.

### 3.3 Factors with a bearing on the actions following the grounding

The *Crete Cement* ran aground in an area where there were plans for the beaching of vessels, among other things, and with ample salvage and oil-spill response resources in relatively close proximity. The environmental damage subsequently proved to be minimal, and this is largely due to the situation being handled in accordance with plans and regulations – from the time when it was decided to beach the vessel until the beaching site was cleared. The decision to beach the vessel was decisive in enabling the subsequent action to be carried out with relatively few problems. The AIBN finds no need to submit any safety recommendation on this point.

### 3.4 Actions taken

#### 3.4.1 Norwegian Hydrographic Service

Norwegian Hydrographic Service has in its response to the draft report informed about the following actions taken in areas covered by the safety recommendations:

*During the time after the accident, guidelines included in the IHO standard S-65 have been established. The Norwegian Hydrographic Service participates in this standardization and will follow up with implementation in the ENC's. Presentation of the T and P messages in ECDIS requires relevant functionality.*

#### 3.4.2 Kristian Gerhard Jebsen Skipsrederi AS

KGJS have in their response to the draft report informed about the following actions taken in areas covered by the safety recommendations:

*Due to the ship's "ice bow", the distance from the lower part of the bow to the collision bulkhead is unusually short. This makes the ship vulnerable when grounding. The sister ship, *Cyprus Cement*, is now fitted with a watertight bulkhead in the pipe trunk, located at frame 105. Another ship in our fleet with the same discharge system, *Cembay*, has been fitted with watertight doors to make it less vulnerable.*

*After the accident we found it necessary to tighten our procedures related to watertight integrity. See attachment. During the development of this procedure we have found very few rules and guidelines for support when giving practical advice to the ships. Among the classification societies only DNV define "Essential openings" which must be marked specifically due to watertight integrity.*

The attachment mentioned can be found in Annex I.



## 4. SAFETY RECOMMENDATIONS

The investigation of this marine accident has identified five areas in which the Accident Investigation Board Norway deems it necessary to propose safety recommendations for the purpose of improving safety at sea.

### **Safety recommendation MARINE no. 2010/14T**

During its voyage through the northern part of Drøbaksundet, the *Crete Cement* did not change course as planned. This was only discovered when it was too late. The officer of the watch's attention was not on the navigation, and the ship's bridge resources were not reinforced when passing through this narrow navigation channel. The AIBN recommends that the owner, Kristian Gerhard Jebsen Skipsrederi AS, implement measures to ensure the presence of sufficient bridge resources at all times for the vessel's crew to be able to navigate the vessel safely and monitor the pilot's navigation.

### **Safety recommendation MARINE no. 2010/15T**

The pilot had been through a strenuous work period in the week before the grounding, even though his work load was within the permitted limits. The AIBN believes that it is highly probable that increased sleepiness contributed to the accident under consideration and it therefore recommends that the Norwegian Coastal Administration evaluate pilots' working hours arrangements, and implements necessary measures if appropriate.

### **Safety recommendation MARINE no. 2010/16T**

The *Crete Cement* had an electronic chart system which did not show the situation in the navigation channel at the time of the accident. The reason for this was that chart corrections describing the construction of new navigational aids in the area had been issued as 'T' and 'P' corrections. These corrections are not implemented in the electronic charts from the Norwegian Mapping Authority – Norwegian Hydrographic Service. There are no international rules relating to the presentation of such corrections, and the AIBN recommends that the Norwegian Mapping Authority – Norwegian Hydrographic Service endeavour to promote IHO's establishment of such rules.

### **Safety recommendation MARINE no. 2010/17T**

The design of the *Crete Cement* means that it is necessary to pass through the engine room bulkhead in order to access some parts of the bilge and ballast equipment. This increases the risk of the vessel's watertight integrity being unsatisfactory if the required closing device is not properly closed, secured and fastened according to the approved arrangements. The AIBN recommends that Bureau Veritas should consider how such an operational issue can be taken into account when examining the drawings of watertight bulkheads provided with access ways, intended to be permanently closed at sea.

**Safety recommendation MARINE no. 2010/18T**

The *Cyprus Cement* is a sister ship to the *Crete Cement* and has a similar manhole in the engine room bulkhead which enables access to parts of the bilge and ballast equipment. The AIBN recommends that the owner implement compensatory measures for the *Cyprus Cement* and any other vessels with the same design.

The Accident Investigation Board Norway  
Lillestrøm, 18 May 2010

**ANNEXES**

Annex A: Relevant abbreviations.

Annex B: Ship drawings

Annex C: Calculations by Det Norske Veritas, ERS.

Annex D: Special collective agreement for state pilots.

Annex E: Overview of individual states' handling of 'P' and 'T' corrections as of January 2009.

Annex F: Expert assessment of the *Crete Cement* accident by Professor Bjørn Bjorvatn, University of Bergen.

Annex G: Service instructions for state pilots.

Annex H: Instructions for the pilot ordering service.

Annex I: KGJS procedure for water tight integrity.

## Annex A:

### ABBREVIATIONS

AIBN	Accident Investigation Board Norway
AIS	Automatic Identification System
BHP	Brake horsepower
BMA	Bahamas Maritime Authority
BRM	Bridge Resource Management
BV	Bureau Veritas
CRM	Crew Resource Management
DWT	Deadweight tonnage
DNV	Det Norske Veritas
ECDIS	Electronic Chart Display and Information System. Electronic chart system that satisfies IMO's standards.
ECS	Electronic Chart System. Electronic chart system that does not satisfy IMO's standards.
Efs	<i>Etterretninger for Sjøfarende</i> (Norwegian Notices to Mariners)
ERS	Emergency Response Service
GPS	Global Positioning System
GT	Gross tonnage
RCC-S	Joint Rescue Coordination Centre South Norway
IHO	International Hydrographic Organization
IMO	International Maritime Organization
ISO	International Organization for Standardization
ISM	International Safety Management
IUA	Intermunicipal committee against acute pollution
KGJS	Kristian Gerhard Jebsen Skipsrederi
LRCC	Local rescue coordination centre
NCA	Norwegian Coastal Administration

NHS	Norwegian Hydrographic Service
NMD	Norwegian Maritime Directorate
PS	Port side
SAFIR	Safety and Improvement Reporting system
SB	Starboard
SOLAS	International Convention for the Safety of Life at Sea
STCW	Standards of Training, Certification and Watchkeeping for seafarers
VTS	Vessel Traffic Services

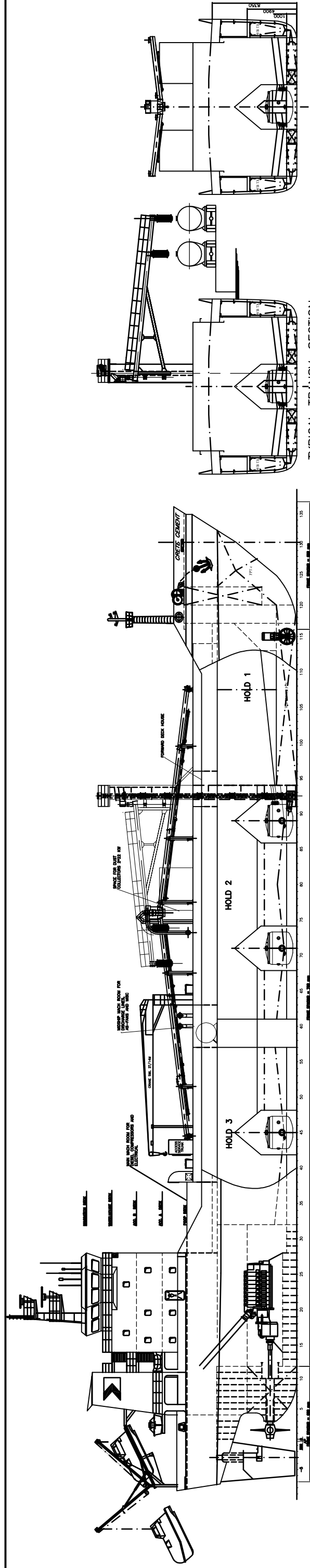

TYPICAL TRANSV. SECTION

TYPICAL TRANSV. SECTION

PROFILE

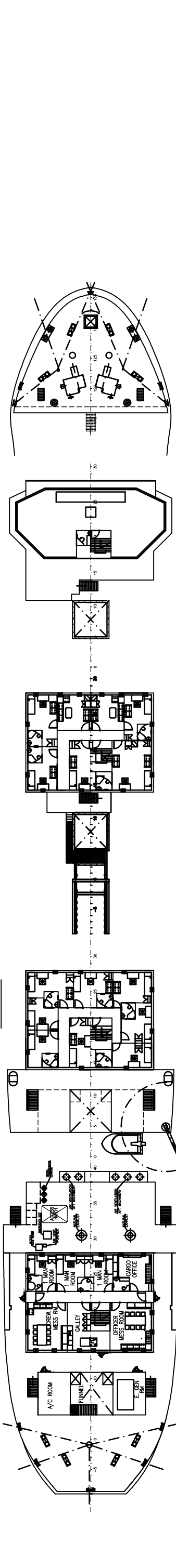

FORECASTLE DECK

WHEELHOUSE DECK

ACCOMMODATION B DECK

ACCOMMODATION A DECK

POOP DECK

PRINCIPAL PARTICULARS

LENGTH OVERALL	97.00 M
LENGTH BP	91.08 M
BREADTH	17.30 M
DEPTH	8.37 M
DRAFT	7.12 M

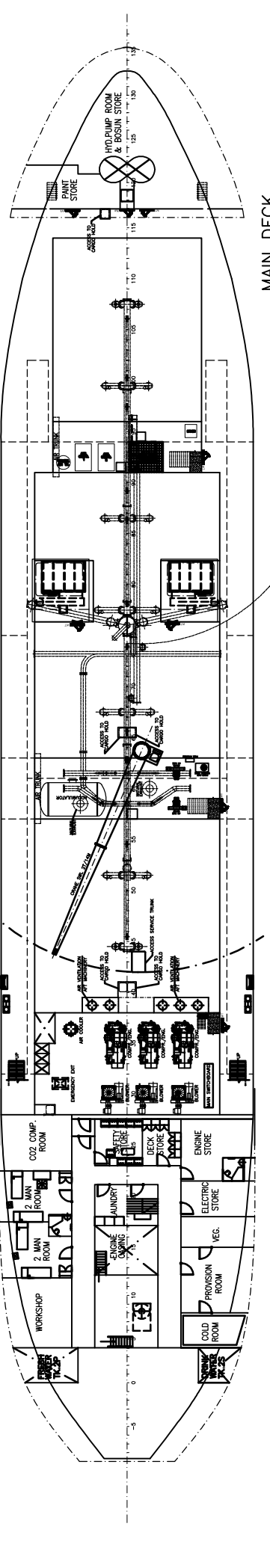

MAIN DECK

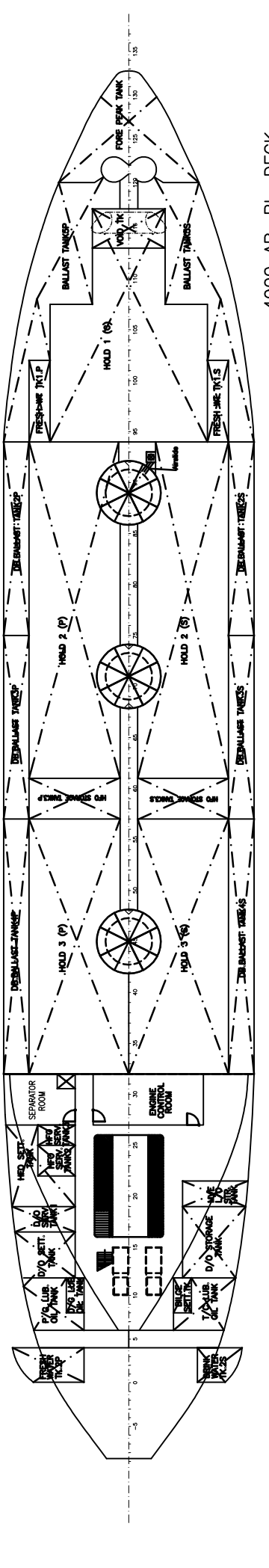

4900 AB. BL. DECK

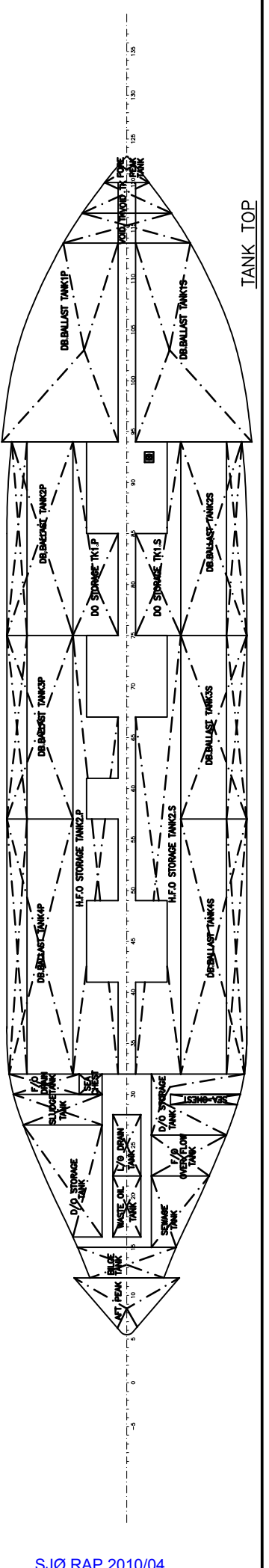

TANK TOP

NO.		MODIFICATIONS		BY		DATE	
<p><b>SHIPTECH</b>                  NAVAL ARCHITECTS                  180 Paya Lebar Road, #08-06,                  Yi-Guang Building, Singapore 409632</p>							
PROJECT				M.V. "CRETE CEMENT"			
TITLE				GENERAL ARRANGEMENT			
E4661				HULL NO.			
DRAWN				GU		SCALE	
CHECKED				7.3.08		ST1446-G1 0	
NOTED				1:200		SHEET	
OF							

APPROVED BY :  
 ON :

This drawing and the information contained herein is supplied on the understanding that they are the property of SHIPTECH Pte Ltd. They must not be reproduced in whole or in part, without permission in writing.

**ISSUE FOR  
CONSTRUCTION**

	NO	MODIFICATIONS	BY	DATE	
<p>APPROVED BY: B.V.</p>	<p><b>SHIPTECH</b> N A V A L   A R C H I T E C T S</p> <p>180 Paya Lebar Road, #08-06, Yi-Guang Building, Singapore 409032</p> <p>Telefax: 67465871      EMail: shiptech@singnet.com.sg      Tel: 67486422</p>				
<p>DATE: 13/JUNE/2006</p>	<p>PROJECT</p> <p><u>M.V "CRETE CEMENT"</u></p>				
<p style="writing-mode: vertical-rl; transform: rotate(180deg);">This drawing and information contained herein is supplied on the understanding that they are the exclusive property of Shiptech Pte Ltd. They must not be used or reproduced in whole or in part, without permission in writing.</p>	<p>TITLE</p> <p>WATERTIGHT HATCH DETAIL (For Void Tank Access @ Bhd. 113)</p>				
	<p>E4653 (A4-200)</p>				
	<p>BUILDER :</p>		<p>HULL NO :</p>		
	<p>DRAWN</p>	<p>OMAR</p>	<p>25/04/06</p>	<p>SCALE</p>	<p>DWG. NO.</p>
<p>CHECKED</p>			<p>NTS</p>	<p>ST1446-S4</p>	
<p>NOTED</p>			<p>TOTAL: 6 PAGES</p>		
<p>SJØ RAP 2010/04</p>					

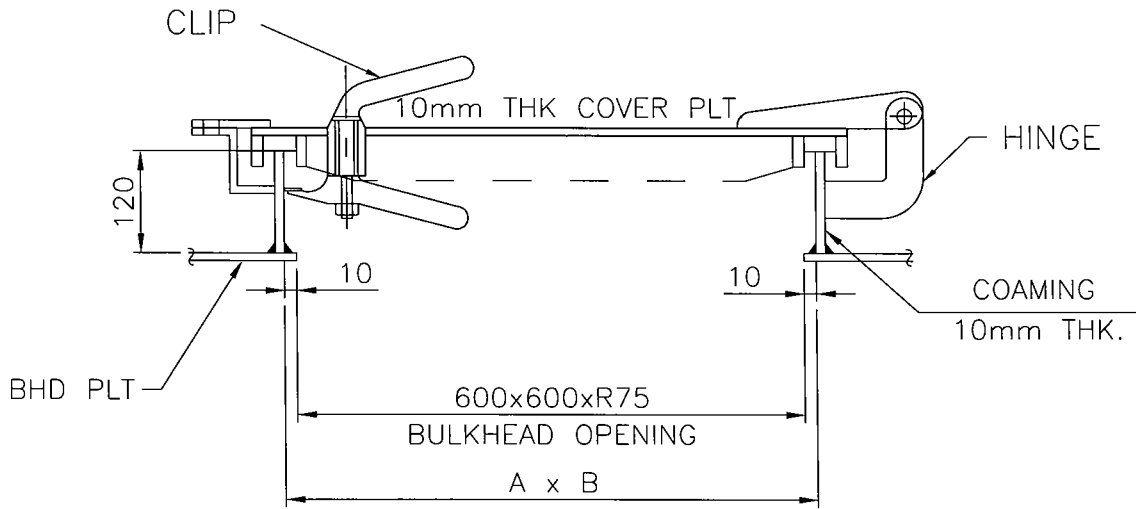

SECTION VIEW OF W.T ACCESS

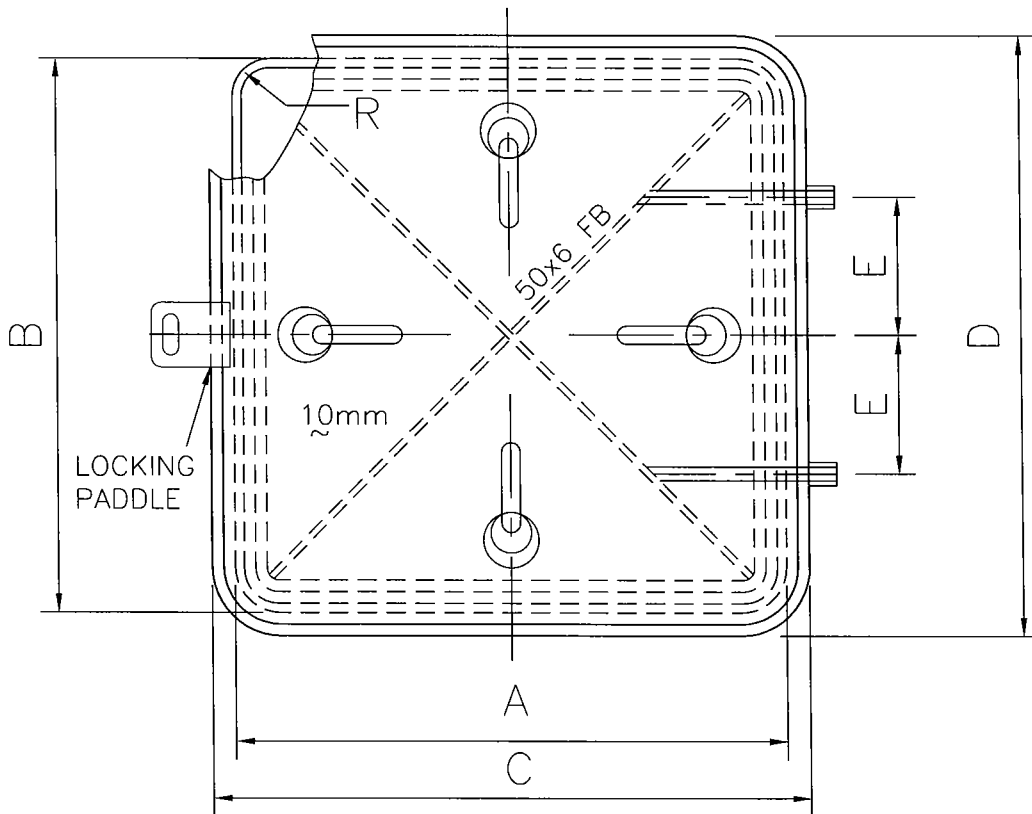

COVER PLATE PLAN FOR W.T. ACCESS

600	620	620	669	669	150	75
SIZE OF HATCH	A	B	C	D	E	R



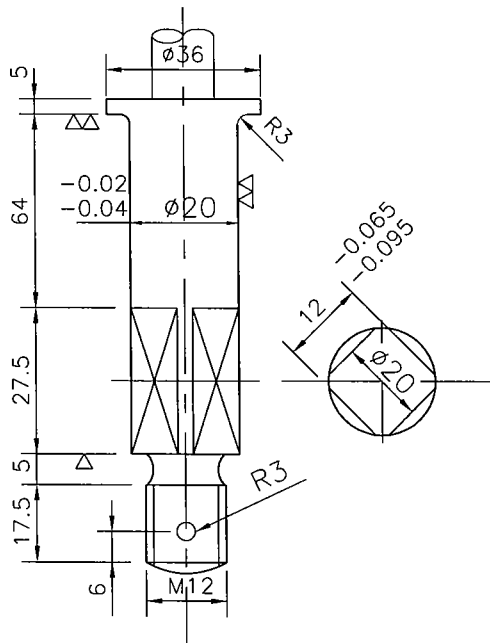
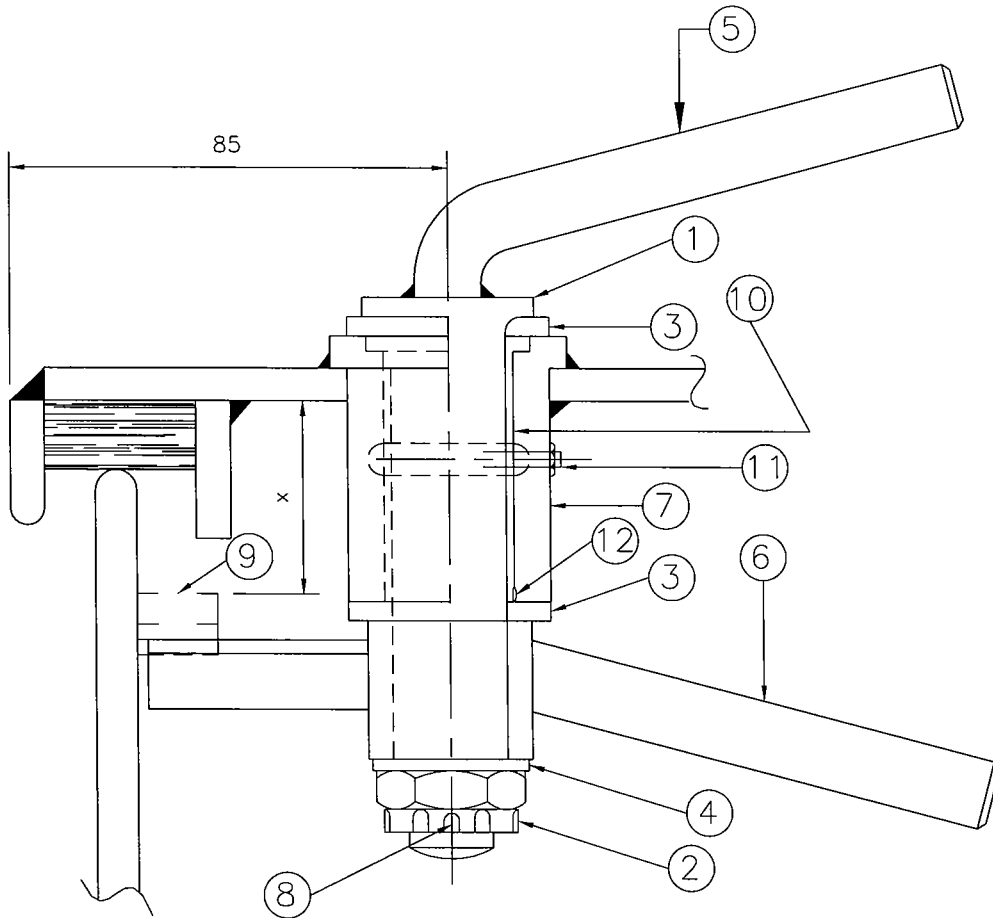

① SPINDLE

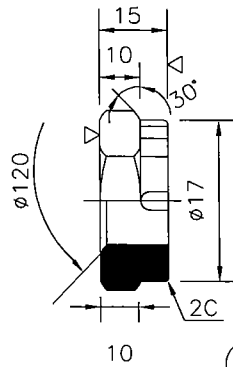

② NUT

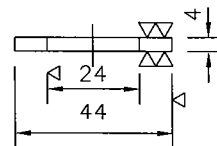
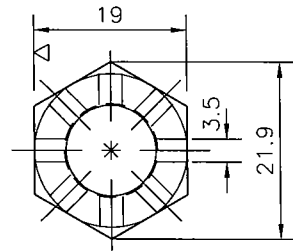

③ WASHER

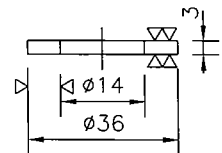

④ WASHER

**SHIPTECH**

NAVAL ARCHITECTS

180 Paya Lebar Road, #08-06,  
Yi-Guang Building, Singapore 1440

TITLE:

TYPICAL CLIP DETAILS

DWG NO.

ST1446-S4

SHEET 4 OF 6

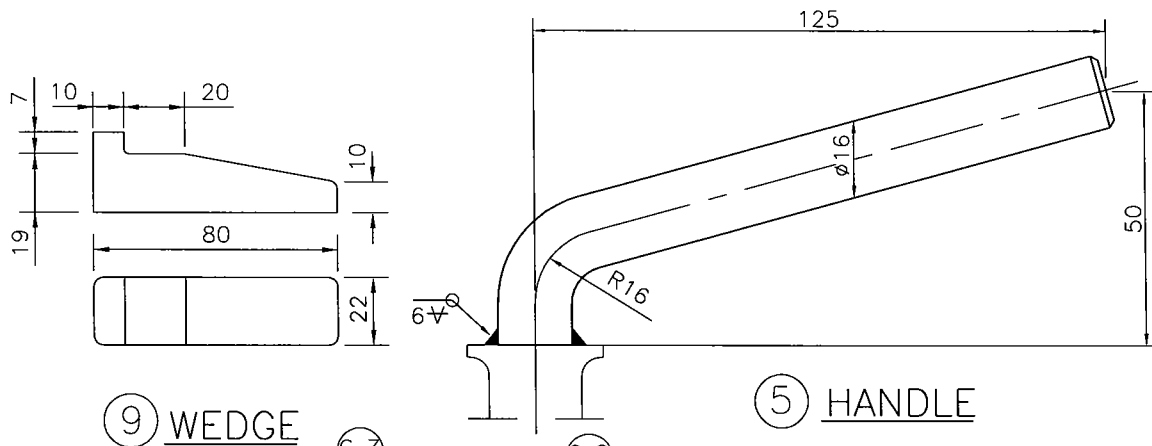

⑨ WEDGE

⑤ HANDLE

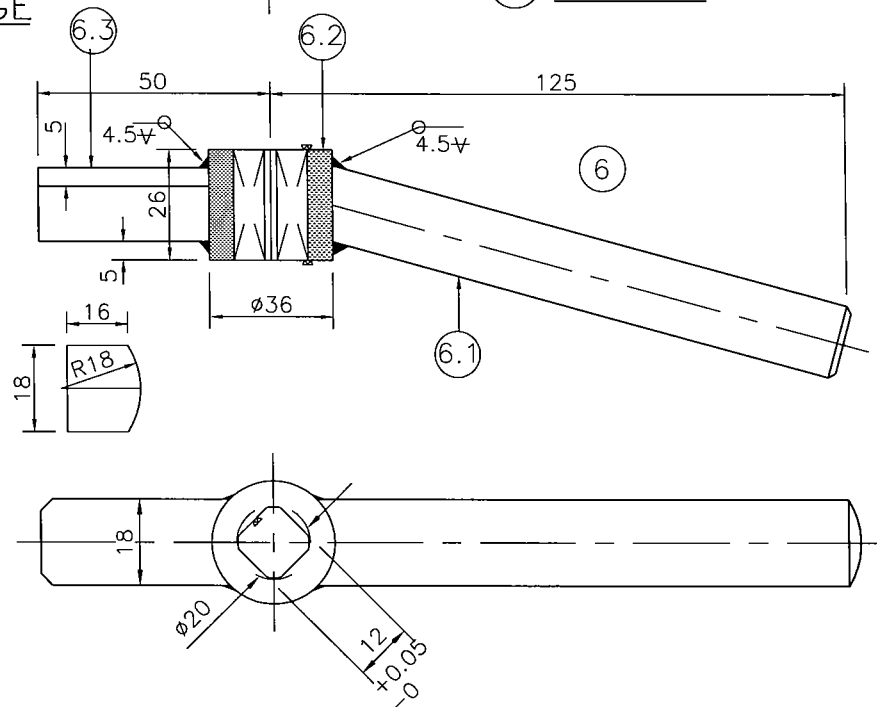

CLIP DETAILS

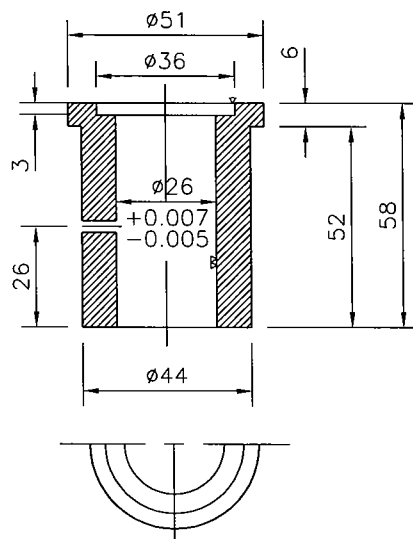

⑦ BOSS

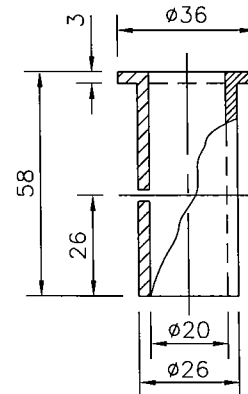

⑩ LINER

**SHIPTECH**

NAVAL ARCHITECTS

180 Paya Lebar Road, #08-06,  
Yi-Guang Building, Singapore 1440

TITLE:

MATERIAL LIST

DWG NO.

ST1446-S4

SHEET 5 OF 6

## MATERIAL LIST ( PER 1 SET )

NO	NAME	MATERIAL	QTY	WT. (KG)	REMARKS
1	SPINDLE	MILD STEEL	1	0.39	
2	NUT	MILD STEEL	1	0.05	
3	WASHER	BRASS PLATE	2	0.08	
4	WASHER	BRASS PLATE	1	0.023	
5	HANDLE	MILD STEEL BAR	1	0.42	
6-1	HANDLE	MILD STEEL BAR	1	0.13	
6-2	BOSS	MILD STEEL	1	0.15	
6-3	LEVER	MILD STEEL	1	0.16	
7	BOSS	MILD STEEL	1	0.58	
8	SPLIT PIN	BRASS WIRE	1	0.006	
9	WEDGE	MILD STEEL	1	0.159	
10	LINER	BRASS	1	0.09	OIL LUBRICATED
11	GREASE NIPPLE	BRASS	1	0.10	
12	∅1.5 GRUB SREW	STAINLESS STEEL	2	0.04	

TOTAL WEIGHT = 2.378

**SHIPTECH**

NAVAL ARCHITECTS

180 Paya Lebar Road, #08-06,  
Yi-Guang Building, Singapore 1440

TITLE:

TYPICAL HINGE DETAILS

DWG NO.

ST1446-S4

SHEET 6 OF 6

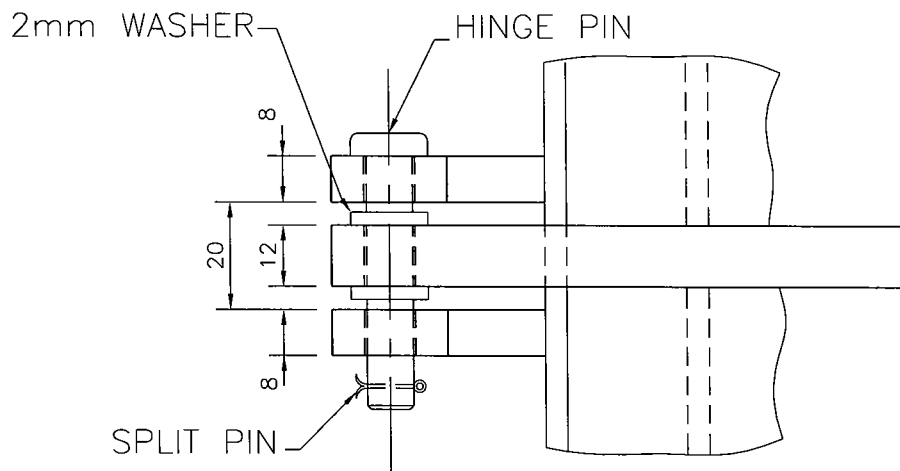
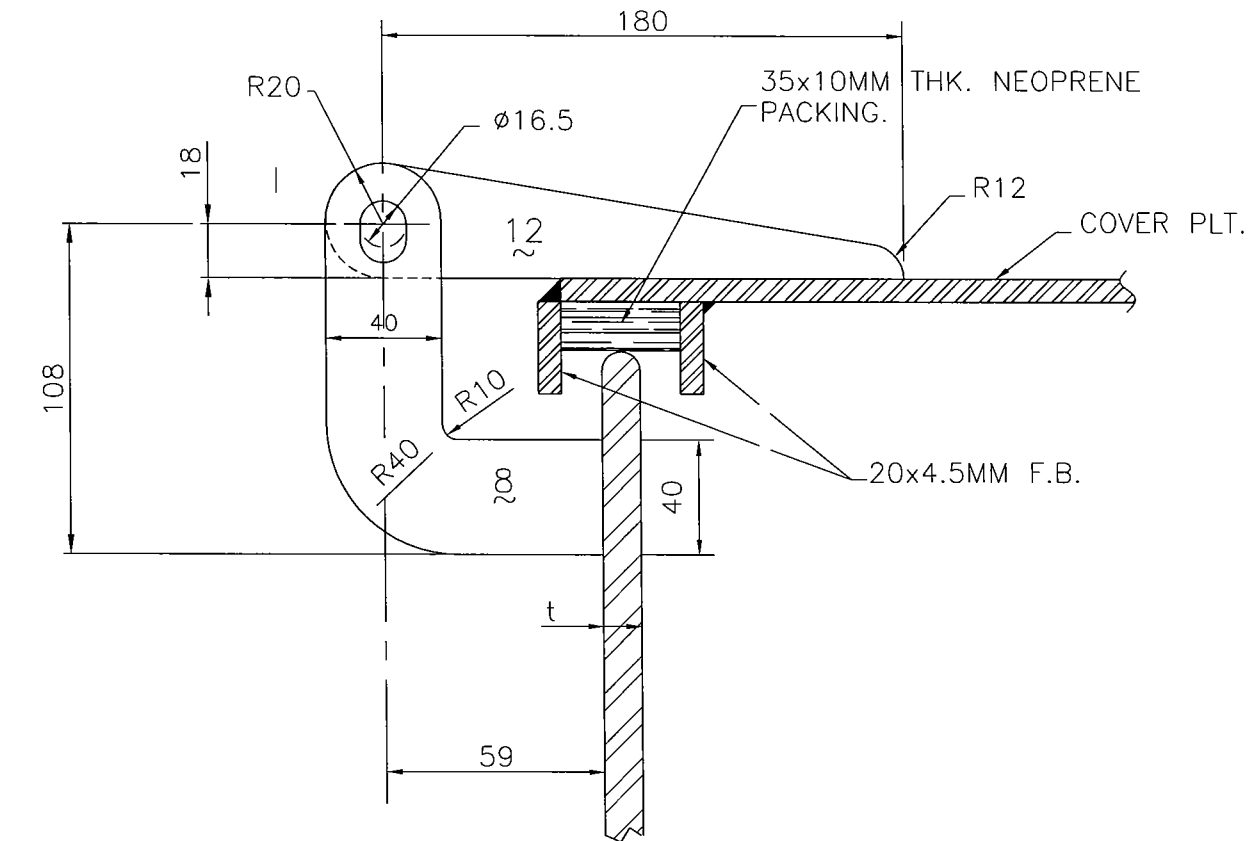
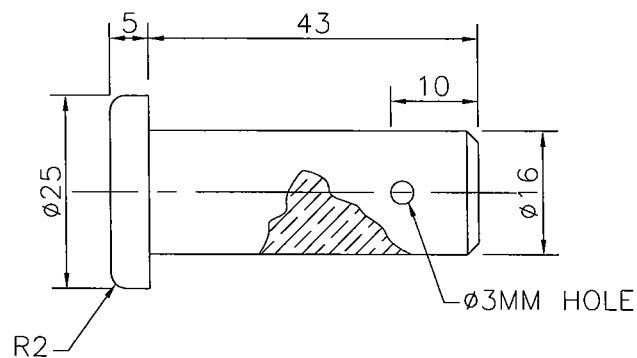
HINGE DETAILSHINGE PIN  
(STAINLESS STEEL)

GENERAL NOTE:-

MANHOLE TO BE OF EQUIVALENT STRENGTH AS ADJACENT BULKHEAD ON DECK

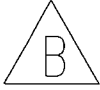

**ISSUE FOR  
CONSTRUCTION**

B	AMENDED AS PER B.V. COMMENT Dd. 13/JUNE/06	OS	27/04
A	AMENDED AS PER OWNERS' COMMENT Dd. 26/04/06	OS	27/04
NO	MODIFICATIONS	BY	DATE

APPROVED BY:

B.V.

DATE:

13/JUNE/2006

# SHIPTECH

## NAVAL ARCHITECTS

180 Paya Lebar Road, #08-06,  
Yi-Guang Building, Singapore 409032

Telefax: 67465871

E-Mail: shiptech@singnet.com.sg

Tel: 67486422

PROJECT

M.V "CRETE CEMENT"

TITLE

MANHOLE COVER DETAILS

E46S3B

BUILDER :

HULL NO :

DRAWN

OMAR

24/04/06

SCALE

DWG. NO.

REV.

CHECKED

NONE

ST1446-S3

B

NOTED

TOTAL: 2 PAGES

SJØ RAP 2010/04

This drawing and information contained herein is supplied on the understanding that they are the exclusive property of Shiptech Pte Ltd. They must not be used or reproduced in whole or in part, without permission in writing.

TITLE:

MANHOLE COVER DETAILS

PAGE 2/2

DATE

BY

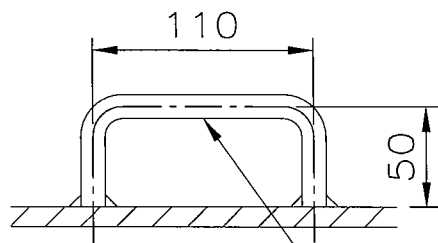
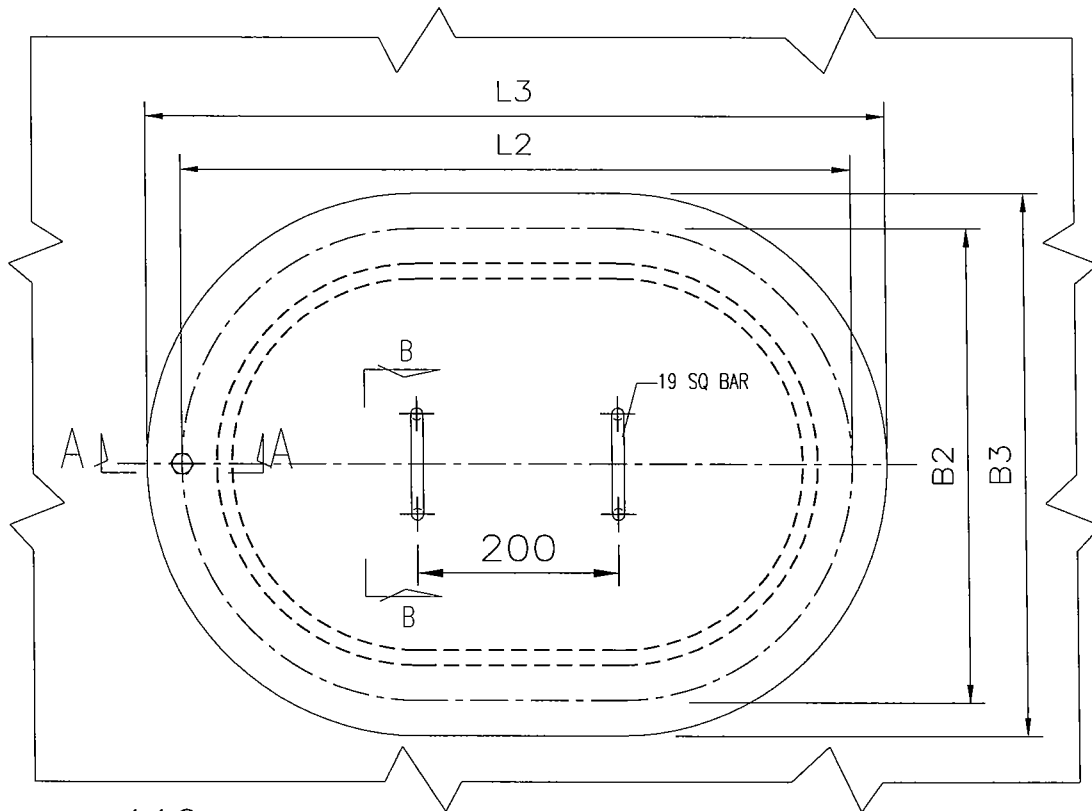

Ø12 S.R BAR  
SECTION B-B

B

PLAN

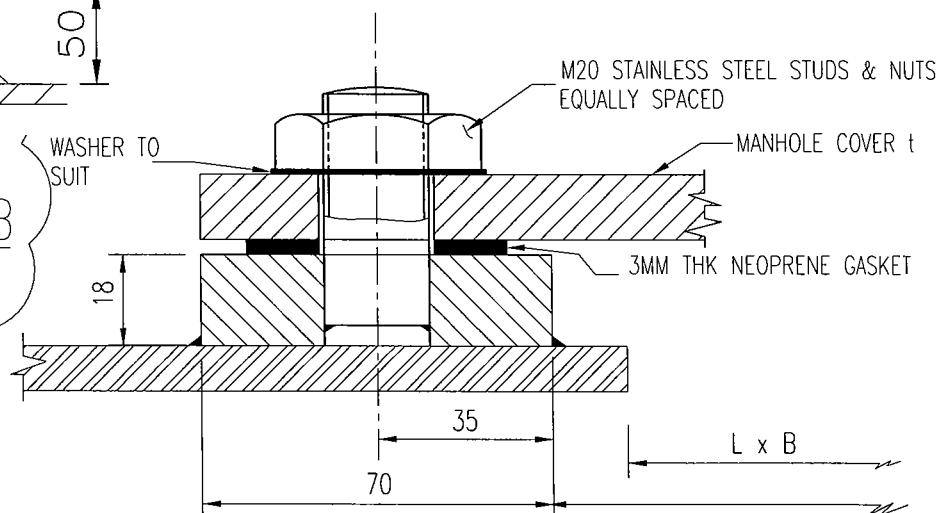

SECTION A-A

CLEAR OPENING		M S RING (INTERNAL)		P.C.D		COVER		t	NO. OF STUDS
L	B	L1	B1	L2	B2	L3	B3		
600	400	630	430	700	500	770	570	10MM	24

PRINCIPAL PARTICULARS

LENGTH OVERALL --- 97.00 M  
 LENGTH BP --- 88.80 M  
 BREADTH MOULDED --- 17.30 M  
 DEPTH MOULDED --- 8.35 M  
 DRAFT --- 7.22 M  
 MAXIMUM CARGO SG. --- 1.30 TONNES/CUM

CLASSIFICATION --- B.V. I • HULL  
 GENERAL CARGO SHIP  
 UNRESTRICTED NAVIGATION

MAXIMUM SWBM:  
 1) AT SEAT (HOGGING) --- 115943 KNM  
 SAGGING --- 98226 KNM

SHIP HAS TO BE EQUIPPED WITH LOADING MANUAL

# DENOTES DIMENSIONS TO BE VERIFIED ON SITE TO SUIT

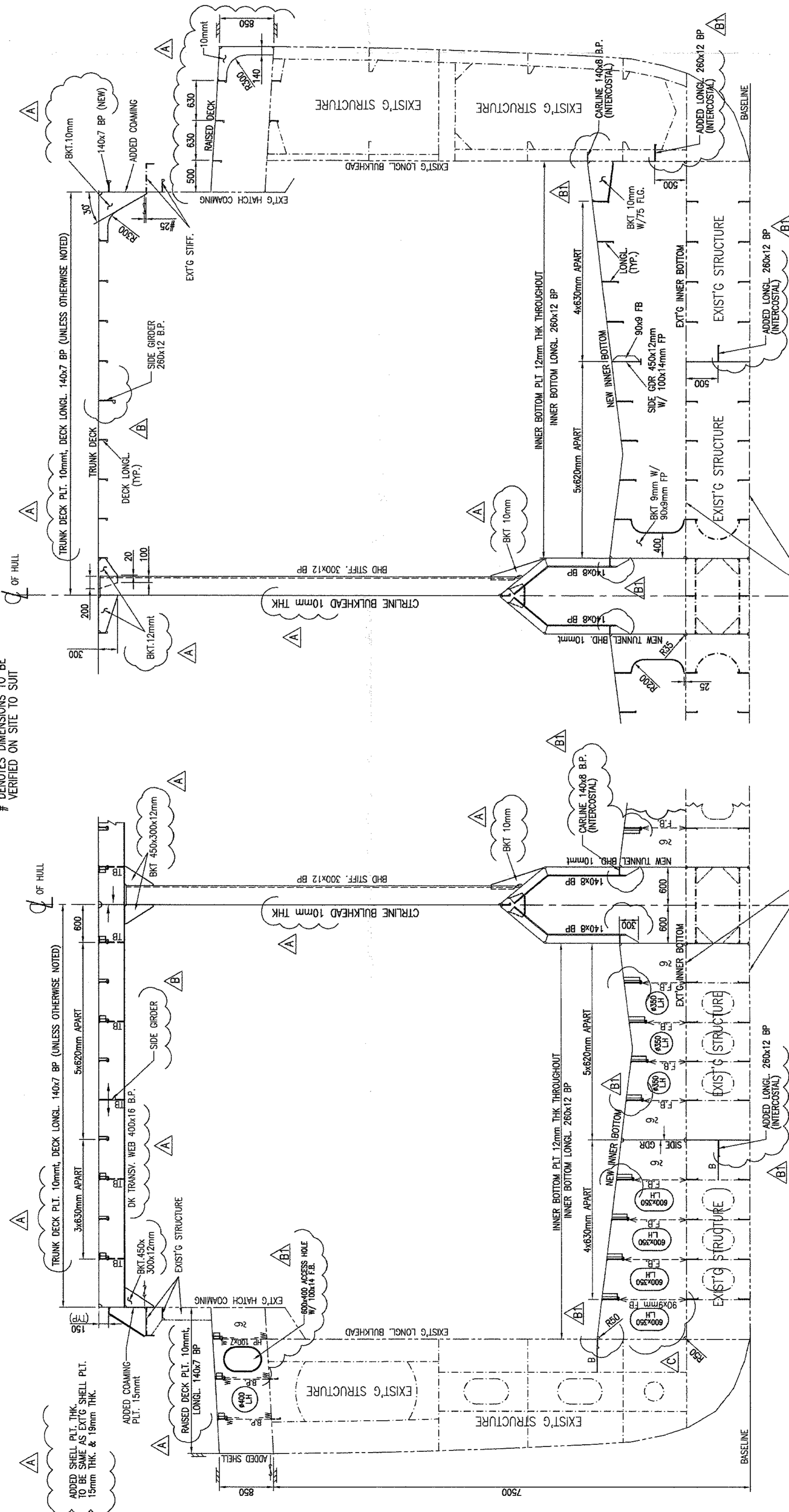

TYP. TRANSV. WEB SECTION I.W.O. CARGO HOLD

TYP. INTERMEDIATE SECTION I.W.O. CARGO HOLD

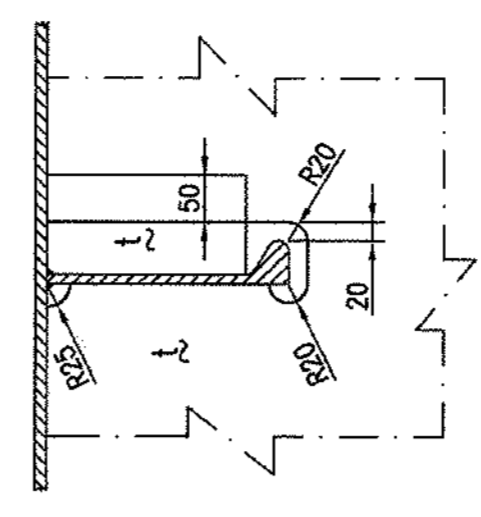
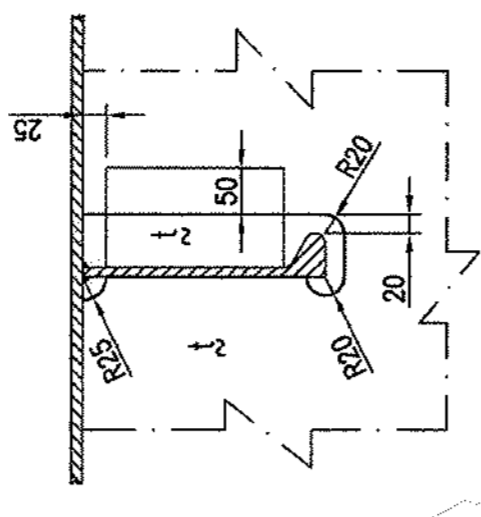
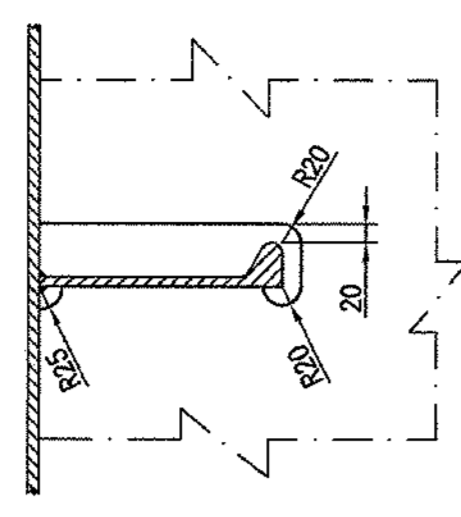
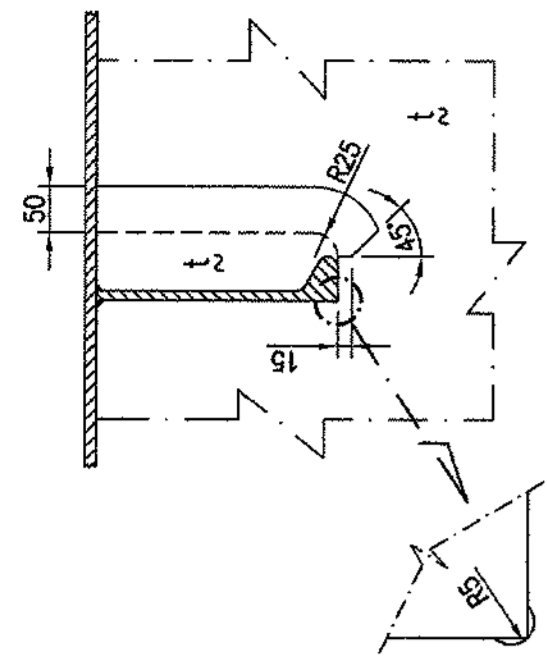

NO.	MODIFICATIONS	BY	DATE
C	AMENDED AS PER OWNER'S COMMENTS D/D 26/APR/2006	JAMES	27/04
B1	AMENDED AS PER B.V. COMMENTS D/D 25/MAR/2006	JAMES	31/03
B	AMENDED AS PER B.V. COMMENTS D/D 27/MAR/2006	JAMES	29/03
A	AMENDED AS PER OWNER'S COMMENTS D/D 14/MAR/2006	JAMES	14/03

**SHIPTECH**  
 NAVAL ARCHITECTS  
 180 Poye Labor Road, #09-08,  
 Y1-Guang Building, Singapore 496032

Telephone: 67465871 Email: shiptech@singnet.com.sg  
 PROJECT: M.V. CRETE CEMENT  
 Tel: 67468422

PRINCIPAL STRUCTURAL SECTIONS

E46H1C.DWG (A1-40)

BUILDER:	HULL NO.:
DRAWN: MZAHMAD NICKR	DWG. NO.:
CHECKED:	SCALE:
NOTED:	1:40
	ST1446-H1
	SHEET
	OF

**ISSUE FOR CONSTRUCTION**

APPROVED BY: B.V.  
 ON: 25/MAR/2006

This drawing and the information contained herein is supplied on the understanding that they are the exclusive property of Shiptech Pte Ltd. They shall not be reproduced in whole or in part, without permission in writing.

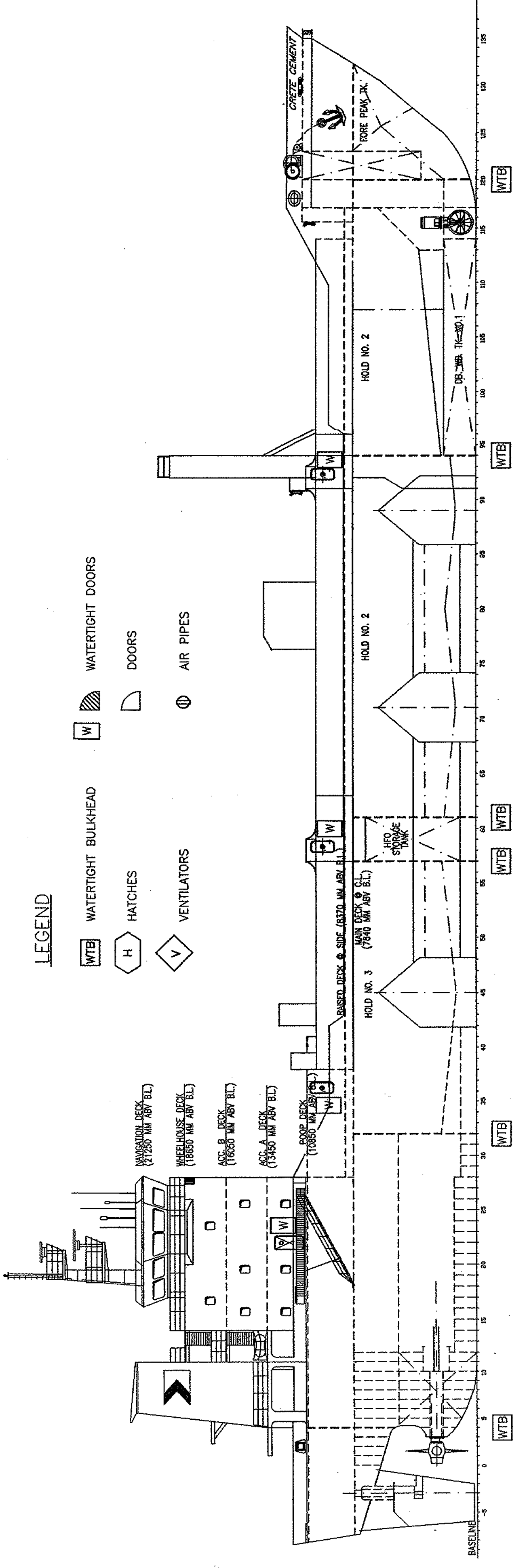

FORECASTLE DECK

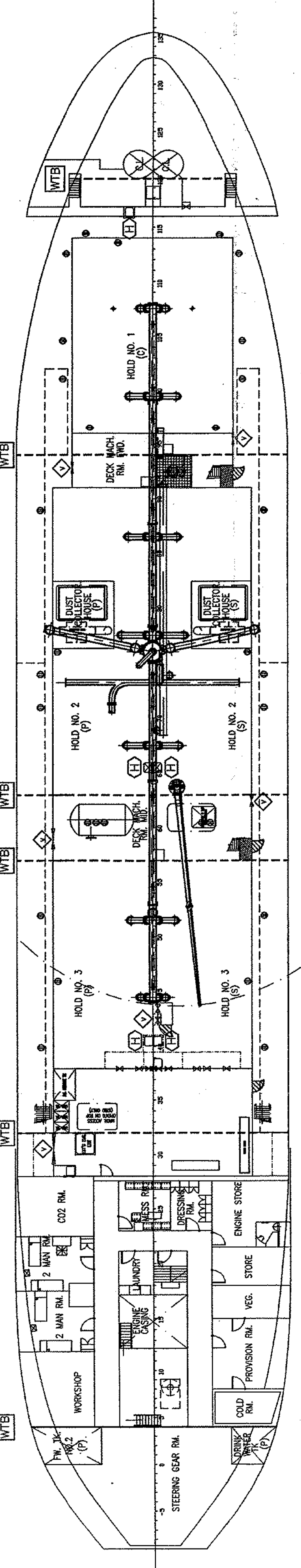

MAIN DECK

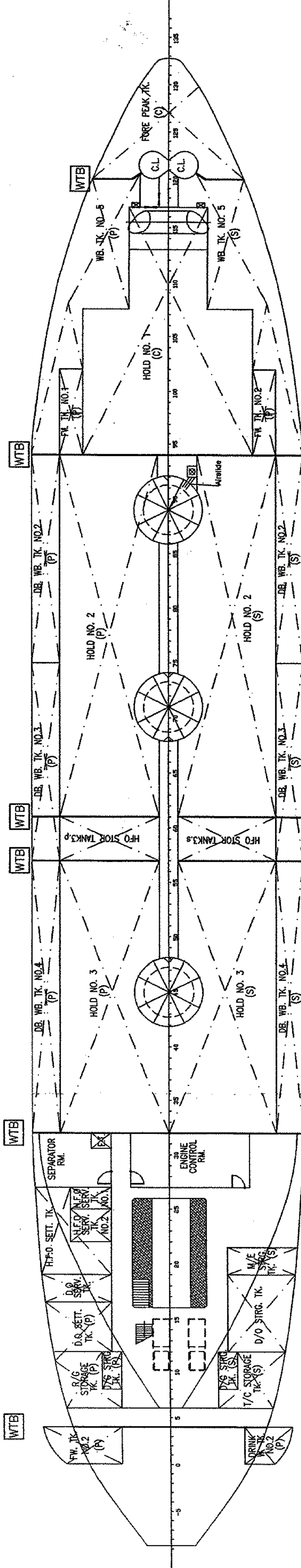

4900 AB. BL. DECK

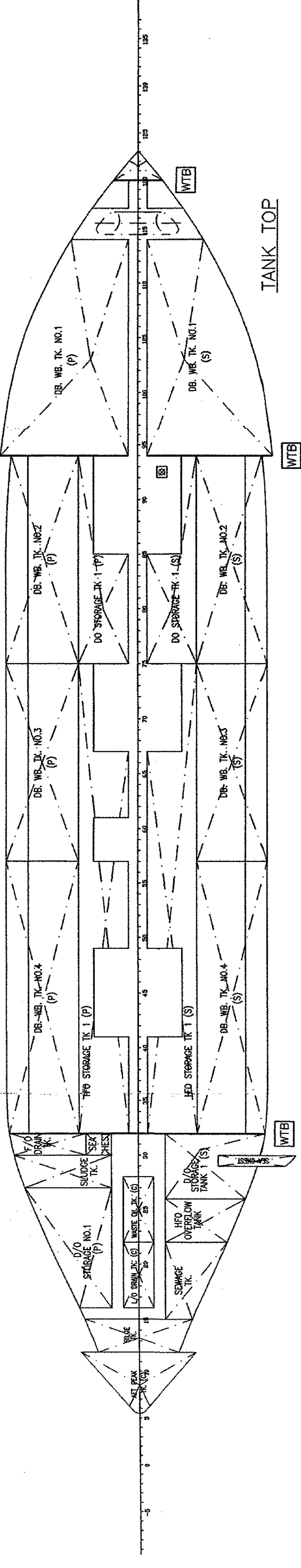

TANK TOP

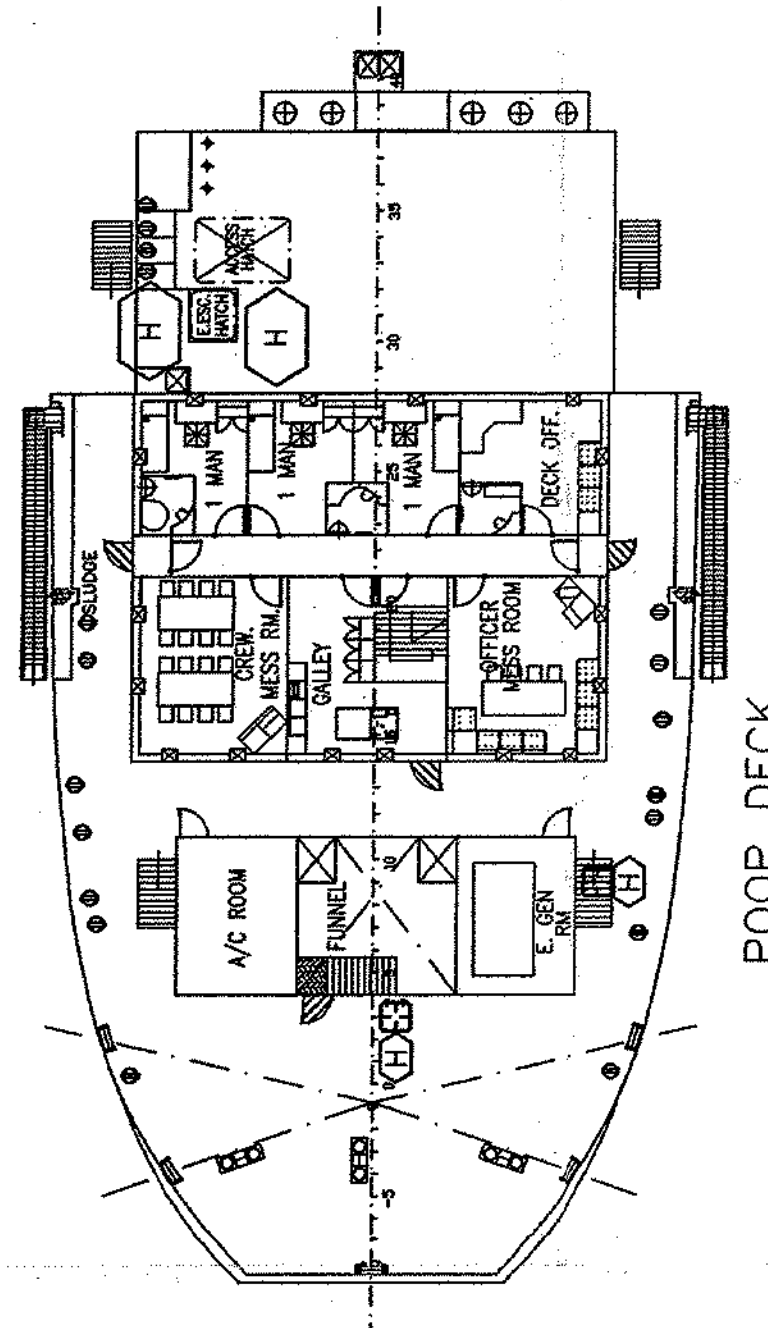
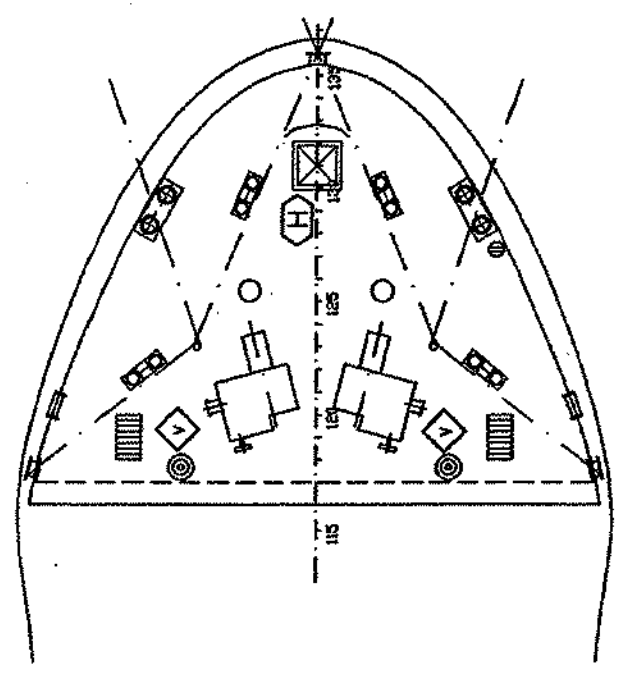

POOP DECK

TO REVISE & RESUBMIT FOR REVIEW.

PRINCIPAL PARTICULARS

LENGTH OVERALL	97.00 M
LENGTH BP	91.08 M
BREADTH	17.50 M
DEPTH	8.37 M

Remarks:  
 1. X,Y,Z coordinates of all weatherlight openings on the foreboard deck is to be stated in this drawing.  
 2. The locations of all bilge and ballast pumps, their control positions and associated valves to be indicated on this drawing.

16 JAN 2007

NO.	MODIFICATIONS	BY	DATE

**SHIPTECH**  
 NAVAL ARCHITECTS  
 180 Pines Laker Road, #08-05  
 Yi-Siang Building, Singapore 499432

Tel: 67455871  
 Email: shiptech@shiptech.com.sg  
 Tel: 67486422

M.V. "CRETE CEMENT"

DAMAGE CONTROL PLAN

E4:6015		HULL NO:	
BUILDER		DWG. NO.	ST1446-G15
DRAWN		SCALE	1:200
CHECKED			
NOTED			

APPROVED BY: \_\_\_\_\_ ON: \_\_\_\_\_  
 This drawing and the information contained herein are the property of SHIPTECH NAVAL ARCHITECTS. They must not be used or reproduced in whole or in part, without permission in writing.



GENERAL :-

- 1) FACE BAR ENDS OF WEBS/ORDERS & STRINGERS TO BE SHIPPED OFF UNLESS OTHERWISE STATED.
- 2) FLANGE ENDS OF FLANGE BRACKETS TO BE SHIPPED OFF.
- 3) ENDS OF FACE BAR OR STIFFENER TO BRACKETS TO BE SHIPPED OFF.
- 4) DIMENSIONS GIVEN ARE FOR GUIDANCE ONLY ACTUAL DIMENSIONS TO BE CHECKED ON SITE

NOTES :-

- 1) ALL MATERIAL TO BE MARINE GRADE AND CLASS APPROVED TYPE.
- 2) ALL WELDS & EDGE PREPARATION TO COMPLY WITH CLASS REQUIREMENT.
- 3) FOR WELDING REF TO WELDING SCHEDULE DETAIL.
- 4) PORT AND STBD. TO BE SYMMETRICAL, UNLESS OTHERWISE STATED.
- 5) ALL SECTIONS DRAWN LOOKING FWD & PORT.
- 6) WHERE WELDINGS ARE NOT POSSIBLE PLUS WELD TO BE APPLIED

REF. DWGS :-

- 601 MIDSHIP SECTION
- 200 LONGITUDINAL SECTION & DECKS
- 251 MIDSHIP SECTION & TRANSVERSE SECTION
- 065-1130-04 LONG. BHD., BHD 32 & SEACHEST
- ST1446-H1 PRINCIPAL STRUCTURAL SECTIONS
- ST1446-H10 PROFILE & DECK (I.W.O. CARGO HOLD)
- ST1446-H11 FRAMING & BULKHEAD SECTIONS (I.W.O. CARGO HOLD)

TYP. WATER-TIGHT NOTCHES & COLLAR PLATE DETAIL

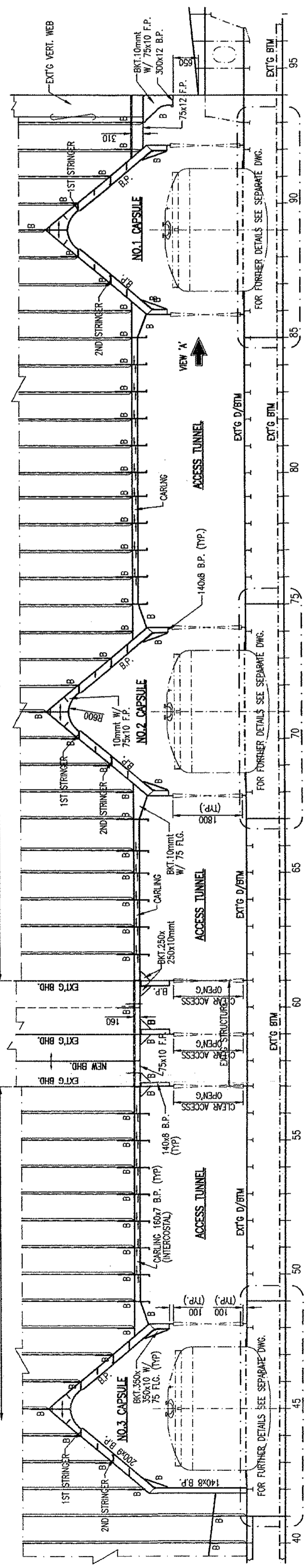
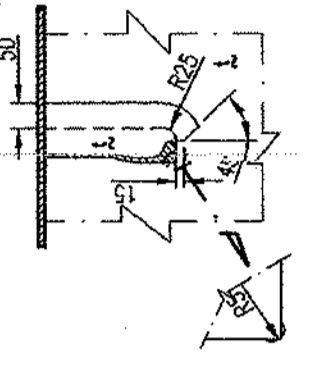

SECTION @ CTRLINE

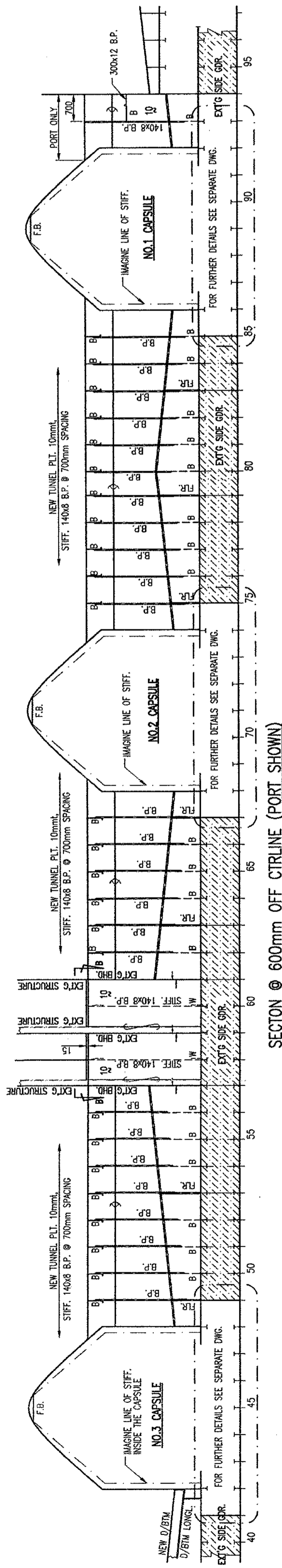

SECTION @ 600mm OFF CTRLINE (PORT SHOWN)

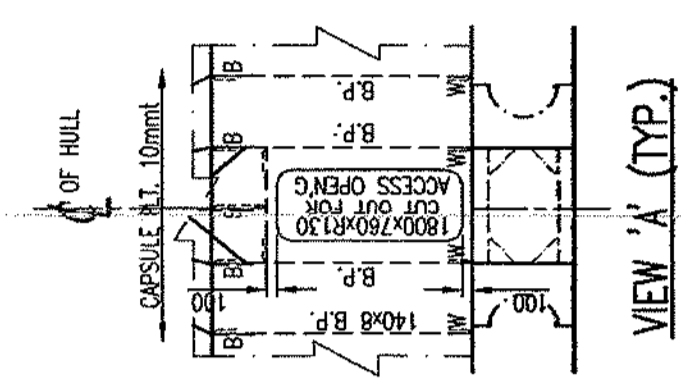
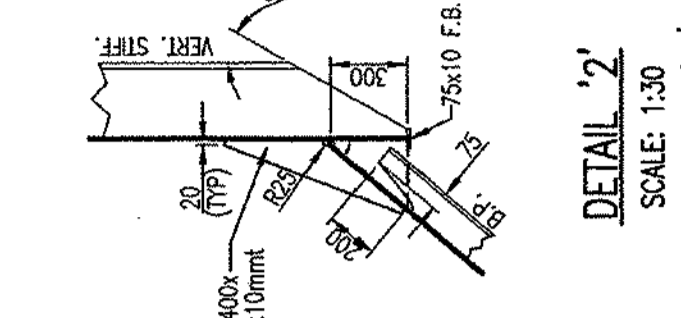
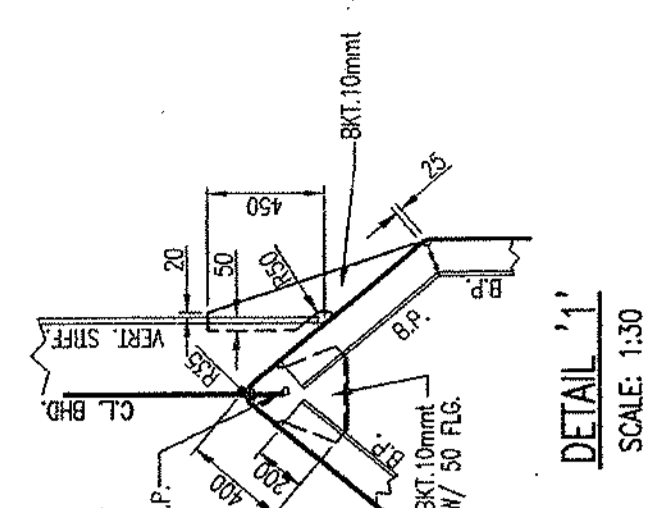
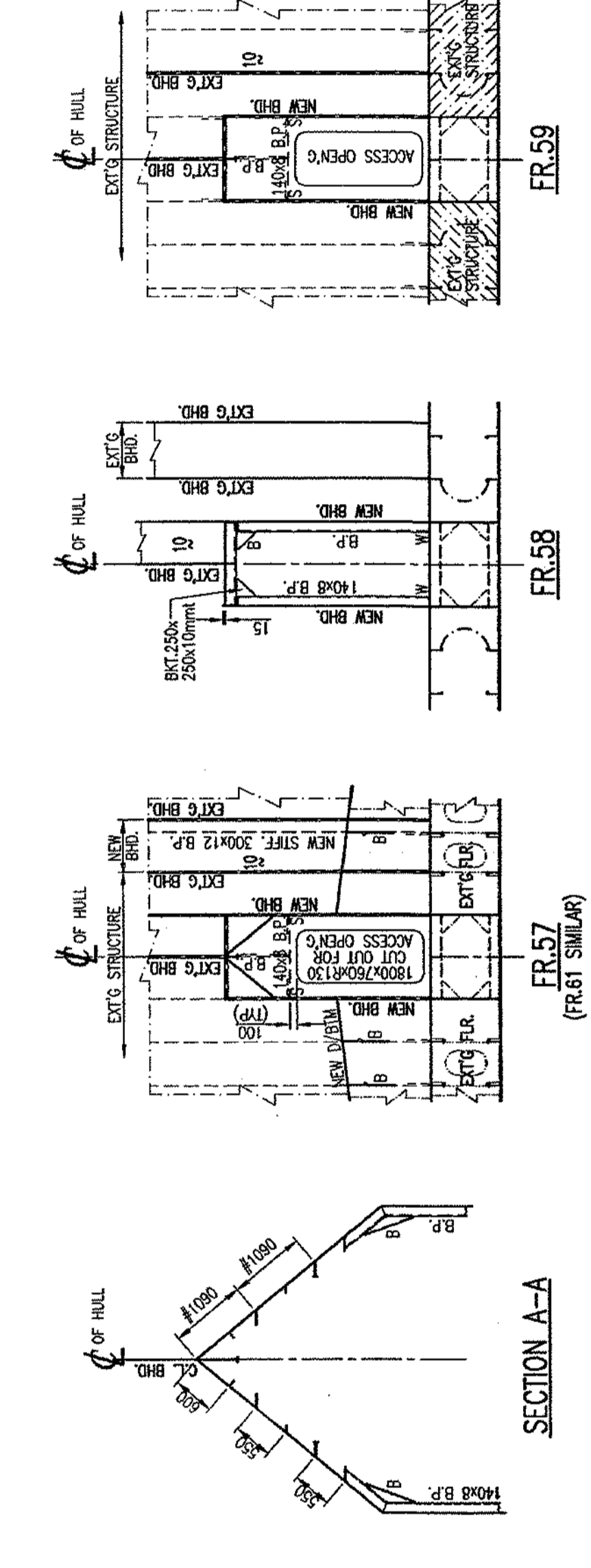
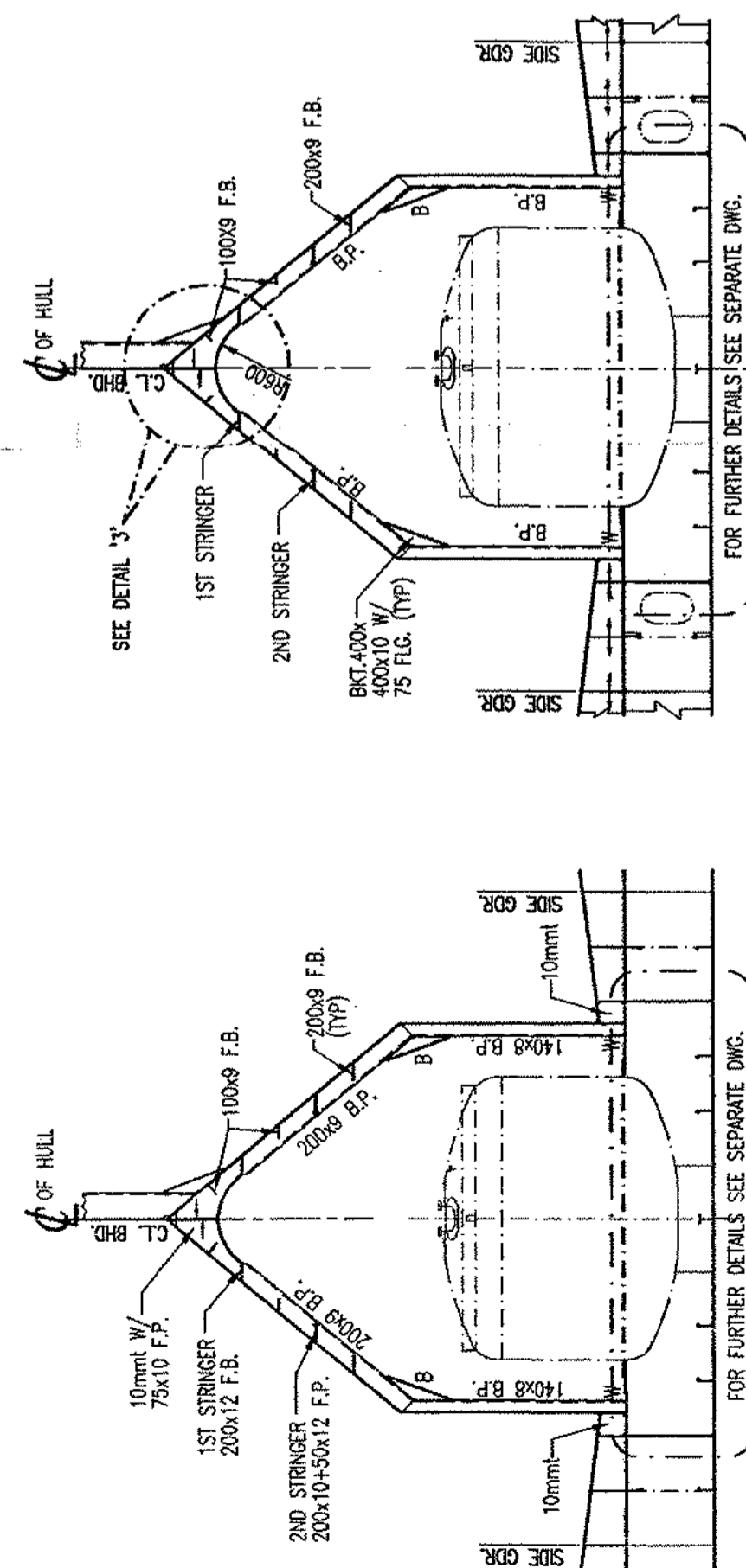

BUREAU VERITAS Section: 02222.H  
 PREVIEWED  
 only for this construction. All parts are the property of the client. Classification to be as per Rules. Singapore 02-01-2006 3 MAR 2006

MODIFICATIONS	BY	DATE
<b>SHIPTECH</b> NAVAL ARCHITECTS 180 Paya Lebar Road, #09-05 Y1-Queong Building, Singapore 409032		
Tel: 67456422		
Email: shiptech@shiptech.com.sg		
PROJECT <b>M.V. CRETE CEMENT</b>		
TITLE <b>CAPSULE AND ACCESS TUNNEL STRUCTURE</b>		
BUILDER: (A1-75) EMBH4	HULL NO:	
DRAWN JAMES KW	SCALE 1:75	DWG. NO. ST1446-H14
CHECKED		REV:
NOTED		SHEET OF

APPROVED BY :  
ON :

This drawing and the information contained herein is supplied on the understanding that they are the exclusive property of Shiptech Pte Ltd. They must not be used or reproduced in whole or in part, without permission in writing.



ACCESS OPENING

ITEM	DESCRIPTION	QTY	LOCATION	TANK
1	600x600xR75 ACCESS OPENG	1	FR.113 @ 1.382 OFF C/LINE(P)	VOID TANK NO1 (C)
2	600x400 MANHOLE	1	FR.55-56 @ 600 OFF C/LINE(P)	VOID TANK NO3 (P)
3	600x400 MANHOLE	1	FR.55-56 @ 600 OFF C/LINE(S)	VOID TANK NO3 (S)
4	600x400 MANHOLE	1	FR.62-63 @ 600 OFF C/LINE(P)	VOID TANK NO3 (P)
5	600x400 MANHOLE	1	FR.62-63 @ 600 OFF C/LINE(S)	VOID TANK NO3 (S)
6	600x400 MANHOLE	1	FR.79-80 @ 600 OFF C/LINE(P)	VOID TANK NO2 (P)
7	600x400 MANHOLE	1	FR.79-80 @ 600 OFF C/LINE(S)	VOID TANK NO2 (S)
8				

REF. DWG.S:-

ST11446-H10 PROFILE & DECKS (I.W.O Cargo Hold)  
 ST11446-H11 FRAMING & BHD. SECTIONS (I.W.O Cargo Hold)  
 ST11446-S2 MANHOLE COVER DETAILS  
 ST11446-S4 W.T HATCH DETAILS (For Void Tank Access @ Bhd. 113)

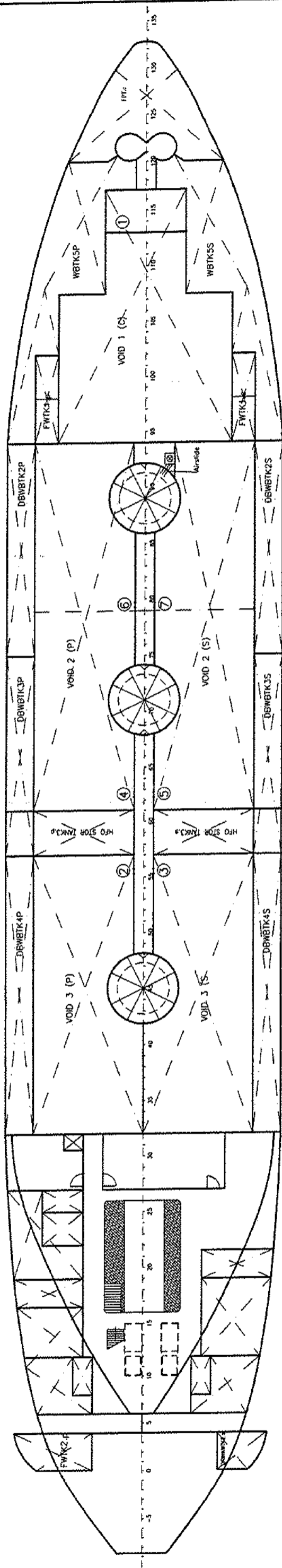

INNER BOTTOM 28 APR 2006

A	AMENDED AS PER OWNERS' COMMENTS Dt. 26/04/06	OS	27/04
NO	MODIFICATIONS	BY	DATE

**SHIPTECH**  
 NAVAL ARCHITECTS  
 180 Paya Lebar Road, #09-06,  
 Yee-Cooeng Building, Singapore 409032

Tel: 67465871 E-Mail: shiptech@singnet.com.sg Tel: 67486422

PROJECT : "M.V. 'CRETE CEMENT'"

TITLE : ACCESS ARRANGEMENT BELOW  
 INNER BOTTOM

E46L3A(A3-250)

DRAWN : OMAR		SCALE : 1/250	DWG NO : ST11446-L3	REV : A
CHK'D	NOTED			

BUREAU VERITAS Coupe 02328#

VU  
 Singapore, le 13-06-2006

Le Chef de Division



# DNV Emergency Response Service

DNV.ID26559

CRETE CEMENT

## CONDITION SUMMARY: INTACT CONDITION

=====

Scenario: GROUNDING08

Condition: Calculaitons for NHT-Initial

Description note:

No notes saved

## FLOATING CONDITION (ACTUAL)

Draft FP	6.93 m	KMT	7.328 m	Strength limits SEA	
Draft M	7.02 m	KG	5.656 m	SFmax	50.4 %
Draft AP	7.10 m	FSC	0.057 m	BMmax	64.3 %
		GMf	1.615 m		
Trim (aft+)	0.16 m	KGf	5.713 m		
Heel (SB+)	0.12 deg				

## INTACT DETAILS

### LOADS

Item	Weight (t)	L.C.G. (m)	T.C.G. (m)	V.C.G. (m)	Frs.mom. (tm)
Bulk cargo	5003.3	50.25	-0.00	5.50	0.0
Water Ballast	4.7	74.22	-0.00	2.04	210.2
Fresh Water	88.7	11.52	-0.26	4.32	18.4
Heavy Fuel Oil	108.5	36.52	-0.92	2.74	213.6
Diesel Oil	19.0	16.35	-3.05	0.57	18.0
Lubricating Oil	12.8	18.62	-1.99	3.49	3.5
MISCELLANEOUS	32.3	14.13	0.10	0.72	0.0
Constants	5.5	15.00	1.11	13.55	0.0
	118.1	35.97	4.29	5.63	0.0
Deadweight	5393.0	48.60	0.06	5.38	463.8
Lightweight	2748.6	39.74	-0.11	6.20	
Displacement (1.025 t/m3)	8141.7	45.60	-0.00	5.66	463.8



DNV

# DNV Emergency Response Service

ANNEX C

2009-03-23

19:10

Page 2

DNV.ID26559

CRETE CEMENT

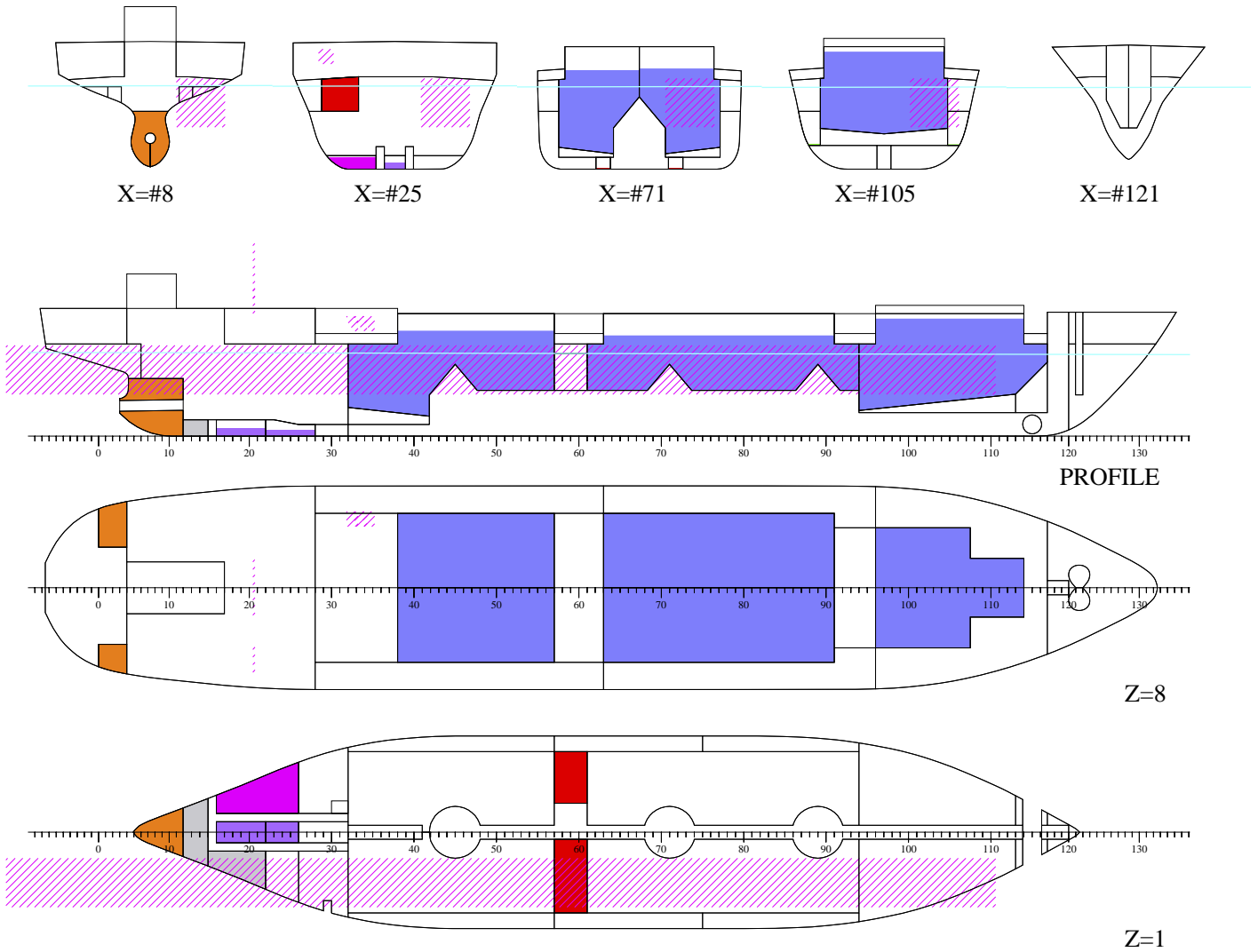

- |                |               |                 |
|----------------|---------------|-----------------|
| Bulk cargo     | Water Ballast | Fresh Water     |
| Heavy Fuel Oil | Diesel Oil    | Lubricating Oil |
| MISCELLANEOUS  | Constants     |                 |



## COMPARTMENT LIST

ID	DES	MASS t	DENS t/m3	FILL %	LCG m	TCG m	VCG m	FRSM tm
CONTENTS : CAB=Bulk cargo (RHO=1.2)								
CH1	No1 cargo hold	996.5	1.200	95.0	72.64	0.00	6.38	0
CH2P	No2 C.Hold.P	1113.3	1.200	79.5	54.83	-3.52	5.17	0
CH2S	No2 C.Hold.S	1113.3	1.200	80.9	54.82	3.51	5.23	0
CH3P	No3 C.Hold.P	890.1	1.200	86.2	31.99	-3.44	5.38	0
CH3S	No3 C.Hold.S	890.1	1.200	86.2	31.99	3.44	5.38	0
SUBTOTAL		5003.3			50.25	-0.00	5.50	0

## CONTENTS : CHA=Chain Locker (RHO=1.025)

CLP	Chain Locker	0.0	1.025	0.0	85.10	-0.94	7.34	0
CLS	Chain Locker	0.0	1.025	0.0	85.10	0.94	7.34	0
SUBTOTAL		0.0			0.00	0.00	0.00	0

## CONTENTS : MASS=Constants (RHO=1)

CREW		4.5	1.000	0.0	15.00	0.00	14.00	0
PROV		1.0	1.000	0.0	15.00	6.11	11.50	0
SUBTOTAL		5.5			15.00	1.11	13.55	0

## CONTENTS : DO=Diesel Oil (RHO=0.85)

30DO1P	No30 DO.Stor..	0.0	0.850	0.0	0.00	0.00	0.00	0
31DO1S	No31 DO.Stor..	0.0	0.850	0.0	0.00	0.00	0.00	0
40DOSTP	No40 DO.Stor.P	19.0	0.850	79.2	16.35	-3.05	0.57	18
41DOS	No41 DO.Stor.S	0.0	0.850	0.0	0.00	0.00	0.00	0
42DOSTS	No42 DO.Stor.S	0.0	0.850	0.0	11.68	4.78	6.57	0
43DOSETP	No43 DO.Sett.P	0.0	0.850	0.0	10.88	-4.69	6.63	0
44DOSP	No44 DO.Serv.P	0.0	0.850	0.0	13.21	-4.95	6.48	0
45DOP	No45 DO.Serv.P	0.0	0.850	0.0	26.15	-5.74	9.65	0
SUBTOTAL		19.0			16.35	-3.05	0.57	18

## CONTENTS : FW=Fresh Water (RHO=1)

20FWT1P	No20 FWT.P	3.9	1.000	10.0	69.20	-6.13	3.07	1
21FWT1S	No21 FWT.S	3.9	1.000	10.0	69.20	6.13	3.07	1
22FWTP	No22 FWT.2P	15.4	1.000	50.0	3.06	-5.15	8.27	12
23DWTS	No23 FWT.2S	9.5	1.000	50.0	3.07	5.96	8.46	4
24APT	No24 Aft Peak	56.0	1.000	100.0	7.25	0.00	2.70	0



# DNV Emergency Response Service



DNV.ID26559

CRETE CEMENT

SUBTOTAL		88.7		11.52	-0.26	4.32	18
----------	--	------	--	-------	-------	------	----

ID	DES	MASS t	DENS t/m3	FILL %	LCG m	TCG m	VCG m	FRSM tm
----	-----	-----------	--------------	-----------	----------	----------	----------	------------

CONTENTS : HFO=Heavy Fuel Oil (RHO=0.96)

32HFO2P	No32 HFO.St.2	6.5	0.960	10.3	36.78	-2.39	0.05	50
33HFO2S	No33 HFO.Stor.	6.5	0.960	9.6	37.14	2.33	0.05	55
34HFO3P	No34 HFO.Stor.	37.0	0.960	38.2	41.90	-3.72	2.21	54
35HFO3S	No35 HFO.Stor.	37.0	0.960	35.7	41.90	3.72	2.13	55
36FOSETP	No36 FO.Stl.P	0.0	0.960	0.0	16.07	-5.88	6.42	0
37FOS1P	No37 HFO.Serv.	8.6	0.960	100.0	18.80	-4.63	6.33	0
38FOS2P	No38 HFO.Serv.	12.9	0.960	100.0	17.05	-4.63	6.33	0
FOVS	No39 F.O.Over.	0.0	0.960	0.0	17.37	3.31	0.68	0
63FODRP	No63 Fo.Drain.	0.0	0.960	0.0	22.31	-4.58	0.53	0

SUBTOTAL		108.5		36.52	-0.92	2.74	214
----------	--	-------	--	-------	-------	------	-----

CONTENTS : LO=Lubricating Oil (RHO=0.9)

50RGLO	No50 RG.LO.P	0.0	0.900	0.0	7.25	-4.14	6.58	0
51DGLOP	No51 DG.LO.P	0.0	0.900	0.0	7.92	-2.99	6.20	0
52LOS	No52 LO.DG.S	0.0	0.900	0.0	7.92	2.99	6.20	0
53TCLOS	No53 TC L.O.S	0.0	0.900	0.0	7.25	4.14	6.58	0
54LOSTRS	No54 ME.LO.S	0.0	0.900	0.0	14.61	5.12	6.43	0
64LODRC	No64 LO.Drain	3.9	0.900	50.0	18.10	0.00	0.35	2
56WOC	No56 Waste.C	4.6	0.900	50.0	13.90	-0.00	0.35	2
57LUB.P		1.5	0.900	0.0	24.75	-5.84	9.56	0
58LUB.P		1.5	0.900	0.0	24.05	-5.84	9.56	0
59LUB.P		1.5	0.900	0.0	23.35	-5.84	9.56	0

SUBTOTAL		12.8		18.62	-1.99	3.49	4
----------	--	------	--	-------	-------	------	---

CONTENTS : MIS=MISCELLANEOUS (RHO=1)

60BT	No.60 Bilge T.	12.1	1.000	100.0	10.12	0.00	0.78	0
61SLUP	No61 Sludge.P	7.9	0.900	100.0	20.58	-3.79	0.53	0
62SEWS	No62 Sewage	12.3	1.000	100.0	13.96	2.69	0.79	0

SUBTOTAL		32.3		14.13	0.10	0.72	0
----------	--	------	--	-------	------	------	---

CONTENTS : MMA=Machinery Sp. (RHO=1)

ER	Engine Room	0.0	1.000	0.0	15.45	0.22	5.39	0
BTR	Bow.Thr.Rm	0.0	1.000	0.0	81.14	-0.00	3.14	0
SGR	Steer.Gear.Rm	0.0	1.000	0.0	0.61	0.19	9.37	0
TUNNEL	Void	0.0	1.000	0.0	52.08	-0.02	1.98	0
MACHAFT	Aft Machine R.	0.0	1.000	0.0	23.65	0.12	9.29	0
MACH-MID	Midship Machi.	0.0	1.000	0.0	42.60	0.00	9.10	0
MACH-FWD	Forward Deckh.	0.0	1.000	0.0	66.05	0.00	9.11	0

SUBTOTAL		0.0		0.00	0.00	0.00	0
----------	--	-----	--	------	------	------	---



# DNV Emergency Response Service

ANNEX C

2009-03-23

19:10

Page 5



DNV.ID26559

CRETE CEMENT

ID	DES	MASS t	DENS t/m3	FILL %	LCG m	TCG m	VCG m	FRSM tm
-----								
CONTENTS : STO=Stores (RHO=1)								
BSN	Bosun Store	0.0	1.000	0.0	86.64	0.00	9.28	0
CONTENTS : MASS= (RHO=0)								
(UNKNOWN_.		118.1	0.000	0.0	35.97	4.29	5.63	0
CONTENTS : VOID=Void (RHO=1.025)								
VSA	Void	0.0	1.025	0.0	13.03	0.00	9.27	0
VS#6	Void	0.0	1.025	0.0	2.78	0.13	7.10	0
CD#15	Void	0.0	1.025	0.0	17.24	-0.06	0.84	0
VS-CH1	Void	0.0	1.025	0.0	73.30	0.00	2.56	0
VS-CH2P	Void	0.0	1.025	0.0	54.28	-4.15	1.47	0
VS-CH2S	Void	0.0	1.025	0.0	54.28	4.15	1.47	0
VS-CH3P	Void	0.0	1.025	0.0	31.34	-3.90	1.54	0
VS-CH3S	Void	0.0	1.025	0.0	31.34	3.90	1.54	0
VS117P	Void	0.0	1.025	0.0	83.12	-1.14	1.47	0
VS117S	Void	0.0	1.025	0.0	83.12	1.14	1.47	0
COFF#57	Coff.above HF.	0.0	1.025	0.0	41.90	0.00	7.39	0
CD-H2S	Void	0.0	1.025	0.0	56.97	7.35	8.01	0
CD-H2P	Void	0.0	1.025	0.0	56.97	-7.35	8.01	0
CD-H3S	Void	0.0	1.025	0.0	32.47	7.49	8.00	0
CD-H3P	Void	0.0	1.025	0.0	32.47	-7.49	8.00	0
PASP	Passage Way P	0.0	1.025	0.0	57.32	-6.63	6.30	0
PASS	Passage Way S	0.0	1.025	0.0	57.32	6.63	6.30	0
CD-H1C	Void	0.0	1.025	0.0	75.97	0.00	8.14	0
-----								
SUBTOTAL		0.0			0.00	0.00	0.00	0
CONTENTS : WB=Water Ballast (RHO=1.025)								
FPT	01 Fore Peak	0.0	1.025	0.0	86.58	0.00	5.75	0
WBT1P	WB02.P	0.0	1.025	0.0	72.06	-3.32	1.08	0
WBT1S	WB03.S	0.0	1.025	0.0	72.06	3.32	1.08	0
WBT2P	WB04.P	0.0	1.025	0.0	59.57	-6.88	2.06	0
WBT2S	WB05.S	0.0	1.025	0.0	59.57	6.88	2.06	0
WBT3P	WB06.P	0.0	1.025	0.0	46.80	-6.92	2.04	0
WBT3S	WB07.S	0.0	1.025	0.0	46.80	6.92	2.04	0
WBT4P	WB08.P	0.0	1.025	0.0	32.13	-6.86	2.06	0
WBT4S	WB09.S	0.0	1.025	0.0	32.13	6.86	2.06	0
WBT5P	WB10.P	2.3	1.025	2.4	74.22	-4.91	2.04	102
WBT5S	WB11.S	2.3	1.025	2.3	74.22	4.91	2.04	108
-----								
SUBTOTAL		4.7			74.22	-0.00	2.04	210
-----								
TOTAL		5393.0			48.60	0.06	5.38	464





DNV

# DNV Emergency Response Service

ANNEX C

2009-03-23

19:10

Page 6

DNV.ID26559

CRETE CEMENT

## STABILITY SUMMARY

=====

### CRITERIA LIST

Environment: INTACT  
Criteria group: CR\_I Defaults

LOADING CONDITION ER#GROUNDING08#1-TMP, Cond.5 Full.Arr

Heel (deg)	0.8	5.0	10.0	20.0	30.0	40.0	45.0
KN (m)	0.099	0.637	1.279	2.400	3.461	4.356	4.720
dGZ (m)	0.001	0.004	0.006	0.010	0.014	0.019	0.021
GZ (m)	0.02	0.14	0.29	0.46	0.62	0.70	0.70
e(phi) (mrad)	0.000	0.006	0.025	0.090	0.184	0.301	0.363

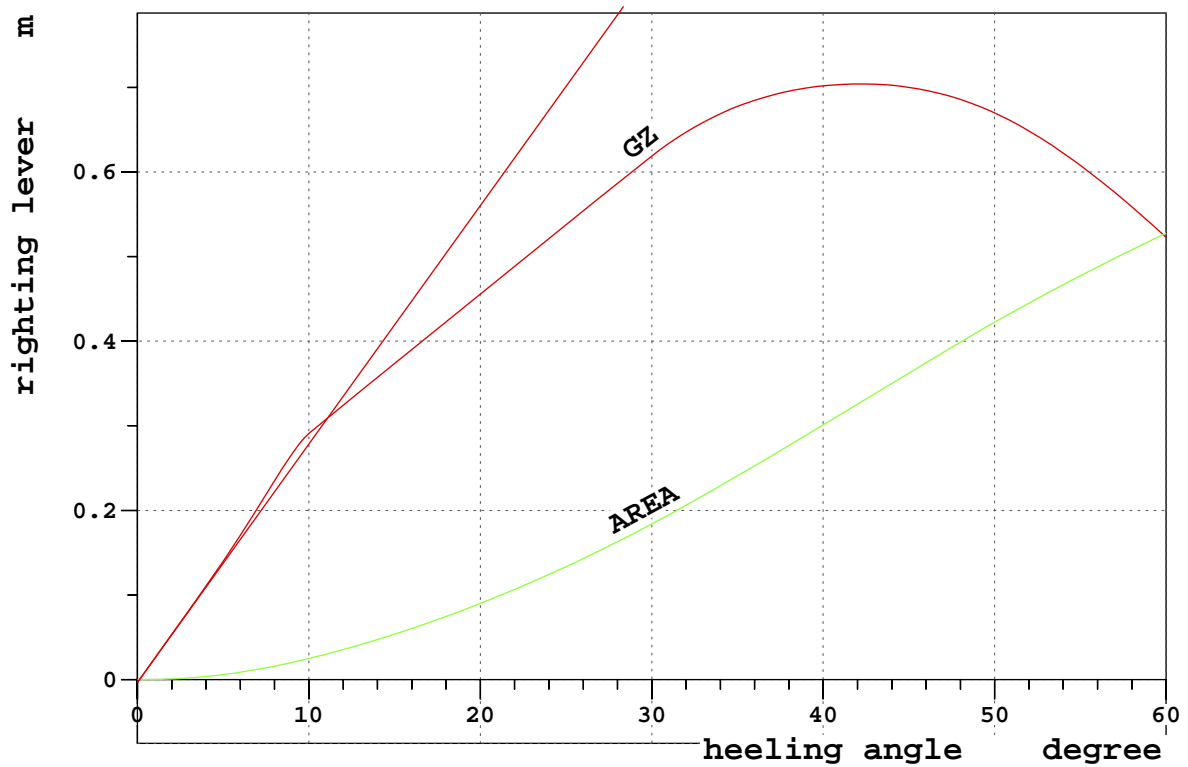



## STRENGTH SUMMARY

=====

LOADING CONDITION ER#GROUNDING08#1-TMP, Cond.5 Full.Arr

		POSITION:	X	FRAME
SHEAR FORCE (MIN)	-198.8 t		23.0 m	32
SHEAR FORCE (MAX)	311.5 t		10.0 m	13
MAX. REL. SHEAR FORCE	50.4 %		10.0 m	13
SAGGING MOMENT	-1.1 tm		-6.1 m	-13
HOGGING MOMENT	4204.7 tm		20.2 m	28
MAX. REL. SAGGING MOMENT	-			
MAX. REL. HOGGING MOMENT	64.3 %		14.8 m	20

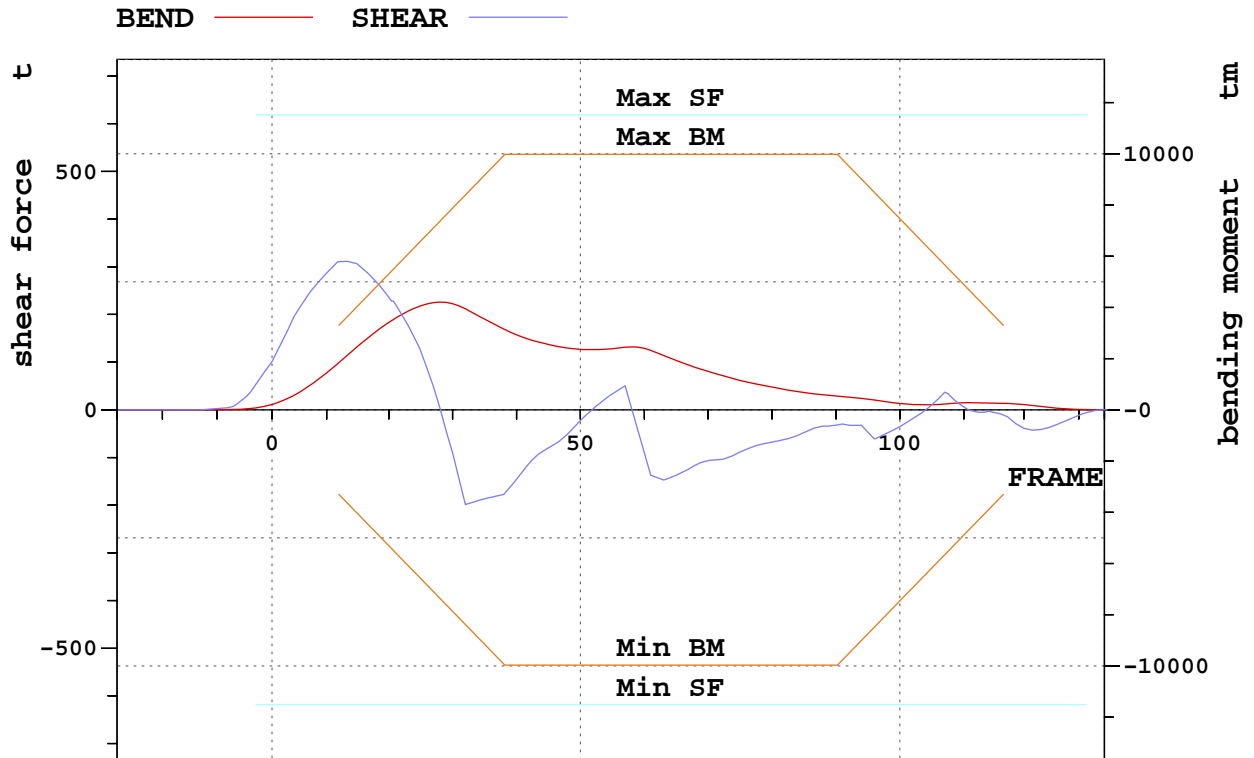



## CONDITION SUMMARY: DAMAGED CONDITION

=====

Scenario: GROUNDING08

Condition: Damage case 1

## Description note:

## Damaged compartments

FPT, DBWBT1P&amp;S, Double Bottom tunnel, Bow truster

## FLOATING CONDITION (ACTUAL)

Draft FP	8.44 m	KMT	7.328 m	Strength limits SEA	
Draft M	7.57 m	KG	5.656 m	SFmax	54.1 %
Draft AP	6.70 m	FSC	0.057 m	BMmax	68.4 %
		GMact	2.181 m	Outflow	0.0 t
Trim (aft+)	-1.74 m	KGint	5.713 m	Sea Ingr.	740.0 t
Heel (SB+)	0.06 deg			Gro Force	0.0 t

## INTACT DETAILS

## LOADS

Item	Weight (t)	L.C.G. (m)	T.C.G. (m)	V.C.G. (m)	Frs.mom. (tm)
Bulk cargo	5003.3	50.25	-0.00	5.50	0.0
Water Ballast	4.7	74.22	-0.00	2.04	210.2
Fresh Water	88.7	11.52	-0.26	4.32	18.4
Heavy Fuel Oil	108.5	36.52	-0.92	2.74	213.6
Diesel Oil	19.0	16.35	-3.05	0.57	18.0
Lubricating Oil	12.8	18.62	-1.99	3.49	3.5
MISCELLANEOUS	32.3	14.13	0.10	0.72	0.0
Constants	5.5	15.00	1.11	13.55	0.0
	118.1	35.97	4.29	5.63	0.0
Deadweight	5393.0	48.60	0.06	5.38	463.8
Lightweight	2748.6	39.74	-0.11	6.20	
Displacement (1.025 t/m3)	8141.7	45.60	-0.00	5.66	463.8



DNV

# DNV Emergency Response Service

ANNEX C

2009-03-23

17:38

Page 2

DNV.ID26559

CRETE CEMENT

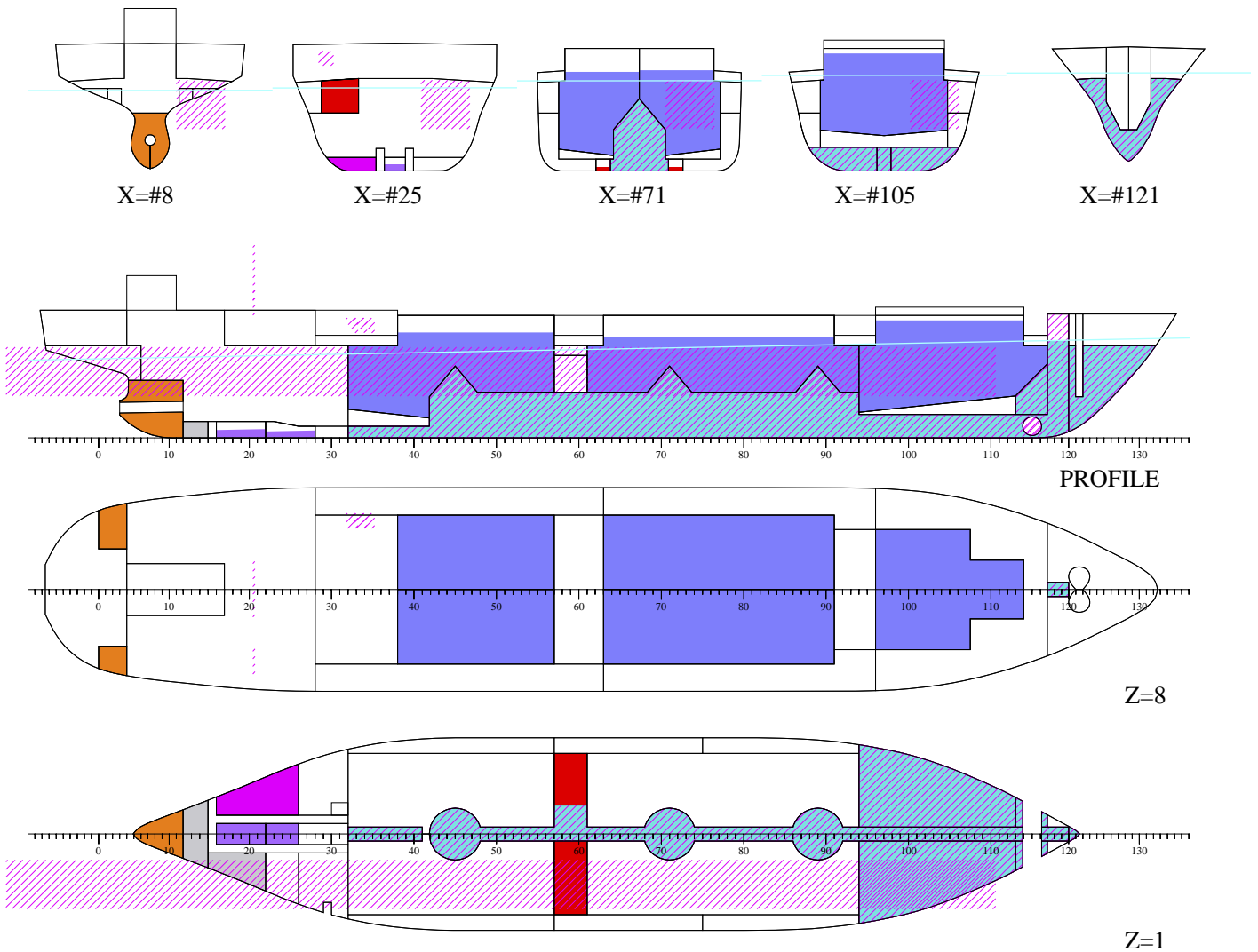

- |                |               |                 |
|----------------|---------------|-----------------|
| Bulk cargo     | Water Ballast | Fresh Water     |
| Heavy Fuel Oil | Diesel Oil    | Lubricating Oil |
| MISCELLANEOUS  | Constants     |                 |



## COMPARTMENT LIST

ID	DES	MASS t	DENS t/m3	FILL %	LCG m	TCG m	VCG m	FRSM tm
CONTENTS : CAB=Bulk cargo (RHO=1.2)								
CH1	No1 cargo hold	996.5	1.200	95.0	72.64	0.00	6.38	0
CH2P	No2 C.Hold.P	1113.3	1.200	79.5	54.83	-3.52	5.17	0
CH2S	No2 C.Hold.S	1113.3	1.200	80.9	54.82	3.51	5.23	0
CH3P	No3 C.Hold.P	890.1	1.200	86.2	31.99	-3.44	5.38	0
CH3S	No3 C.Hold.S	890.1	1.200	86.2	31.99	3.44	5.38	0
SUBTOTAL		5003.3			50.25	-0.00	5.50	0

## CONTENTS : CHA=Chain Locker (RHO=1.025)

CLP	Chain Locker	0.0	1.025	0.0	85.10	-0.94	7.34	0
CLS	Chain Locker	0.0	1.025	0.0	85.10	0.94	7.34	0
SUBTOTAL		0.0			0.00	0.00	0.00	0

## CONTENTS : MASS=Constants (RHO=1)

CREW		4.5	1.000	0.0	15.00	0.00	14.00	0
PROV		1.0	1.000	0.0	15.00	6.11	11.50	0
SUBTOTAL		5.5			15.00	1.11	13.55	0

## CONTENTS : DO=Diesel Oil (RHO=0.85)

30DO1P	No30 DO.Stor..	0.0	0.850	0.0	0.00	0.00	0.00	0
31DO1S	No31 DO.Stor..	0.0	0.850	0.0	0.00	0.00	0.00	0
40DOSTP	No40 DO.Stor.P	19.0	0.850	79.2	16.35	-3.05	0.57	18
41DOS	No41 DO.Stor.S	0.0	0.850	0.0	0.00	0.00	0.00	0
42DOSTS	No42 DO.Stor.S	0.0	0.850	0.0	11.68	4.78	6.57	0
43DOSETP	No43 DO.Sett.P	0.0	0.850	0.0	10.88	-4.69	6.63	0
44DOSP	No44 DO.Serv.P	0.0	0.850	0.0	13.21	-4.95	6.48	0
45DOP	No45 DO.Serv.P	0.0	0.850	0.0	26.15	-5.74	9.65	0
SUBTOTAL		19.0			16.35	-3.05	0.57	18

## CONTENTS : FW=Fresh Water (RHO=1)

20FWT1P	No20 FWT.P	3.9	1.000	10.0	69.20	-6.13	3.07	1
21FWT1S	No21 FWT.S	3.9	1.000	10.0	69.20	6.13	3.07	1
22FWTP	No22 FWT.2P	15.4	1.000	50.0	3.06	-5.15	8.27	12
23DWTS	No23 FWT.2S	9.5	1.000	50.0	3.07	5.96	8.46	4
24APT	No24 Aft Peak	56.0	1.000	100.0	7.25	0.00	2.70	0



# DNV Emergency Response Service

ANNEX C

2009-03-23

17:38

Page 4



DNV.ID26559

CRETE CEMENT

SUBTOTAL		88.7			11.52	-0.26	4.32	18
----------	--	------	--	--	-------	-------	------	----

ID	DES	MASS t	DENS t/m3	FILL %	LCG m	TCG m	VCG m	FRSM tm
----	-----	-----------	--------------	-----------	----------	----------	----------	------------

CONTENTS : HFO=Heavy Fuel Oil (RHO=0.96)

32HFO2P	No32 HFO.St.2	6.5	0.960	10.3	36.78	-2.39	0.05	50
33HFO2S	No33 HFO.Stor.	6.5	0.960	9.6	37.14	2.33	0.05	55
34HFO3P	No34 HFO.Stor.	37.0	0.960	38.2	41.90	-3.72	2.21	54
35HFO3S	No35 HFO.Stor.	37.0	0.960	35.7	41.90	3.72	2.13	55
36FOSETP	No36 FO.Stl.P	0.0	0.960	0.0	16.07	-5.88	6.42	0
37FOS1P	No37 HFO.Serv.	8.6	0.960	100.0	18.80	-4.63	6.33	0
38FOS2P	No38 HFO.Serv.	12.9	0.960	100.0	17.05	-4.63	6.33	0
FOVS	No39 F.O.Over.	0.0	0.960	0.0	17.37	3.31	0.68	0
63FODRP	No63 Fo.Drain.	0.0	0.960	0.0	22.31	-4.58	0.53	0

SUBTOTAL		108.5			36.52	-0.92	2.74	214
----------	--	-------	--	--	-------	-------	------	-----

CONTENTS : LO=Lubricating Oil (RHO=0.9)

50RGLO	No50 RG.LO.P	0.0	0.900	0.0	7.25	-4.14	6.58	0
51DGLOP	No51 DG.LO.P	0.0	0.900	0.0	7.92	-2.99	6.20	0
52LOS	No52 LO.DG.S	0.0	0.900	0.0	7.92	2.99	6.20	0
53TCLOS	No53 TC L.O.S	0.0	0.900	0.0	7.25	4.14	6.58	0
54LOSTRS	No54 ME.LO.S	0.0	0.900	0.0	14.61	5.12	6.43	0
64LODRC	No64 LO.Drain	3.9	0.900	50.0	18.10	0.00	0.35	2
56WOC	No56 Waste.C	4.6	0.900	50.0	13.90	-0.00	0.35	2
57LUB.P		1.5	0.900	0.0	24.75	-5.84	9.56	0
58LUB.P		1.5	0.900	0.0	24.05	-5.84	9.56	0
59LUB.P		1.5	0.900	0.0	23.35	-5.84	9.56	0

SUBTOTAL		12.8			18.62	-1.99	3.49	4
----------	--	------	--	--	-------	-------	------	---

CONTENTS : MIS=MISCELLANEOUS (RHO=1)

60BT	No.60 Bilge T.	12.1	1.000	100.0	10.12	0.00	0.78	0
61SLUP	No61 Sludge.P	7.9	0.900	100.0	20.58	-3.79	0.53	0
62SEWS	No62 Sewage	12.3	1.000	100.0	13.96	2.69	0.79	0

SUBTOTAL		32.3			14.13	0.10	0.72	0
----------	--	------	--	--	-------	------	------	---

CONTENTS : MMA=Machinery Sp. (RHO=1)

ER	Engine Room	0.0	1.000	0.0	15.45	0.22	5.39	0
BTR	Bow.Thr.Rm	0.0	1.000	0.0	81.14	-0.00	3.14	0
SGR	Steer.Gear.Rm	0.0	1.000	0.0	0.61	0.19	9.37	0
TUNNEL	Void	0.0	1.000	0.0	52.08	-0.02	1.98	0
MACHAFT	Aft Machine R.	0.0	1.000	0.0	23.65	0.12	9.29	0
MACH-MID	Midship Machi.	0.0	1.000	0.0	42.60	0.00	9.10	0
MACH-FWD	Forward Deckh.	0.0	1.000	0.0	66.05	0.00	9.11	0

SUBTOTAL		0.0			0.00	0.00	0.00	0
----------	--	-----	--	--	------	------	------	---



# DNV Emergency Response Service

ANNEX C

2009-03-23

17:38

Page 5



DNV.ID26559

CRETE CEMENT

ID	DES	MASS t	DENS t/m3	FILL %	LCG m	TCG m	VCG m	FRSM tm
-----								
CONTENTS : STO=Stores (RHO=1)								
BSN	Bosun Store	0.0	1.000	0.0	86.64	0.00	9.28	0
CONTENTS : MASS= (RHO=0)								
(UNKNOWN_.		118.1	0.000	0.0	35.97	4.29	5.63	0
CONTENTS : VOID=Void (RHO=1.025)								
VSA	Void	0.0	1.025	0.0	13.03	0.00	9.27	0
VS#6	Void	0.0	1.025	0.0	2.78	0.13	7.10	0
CD#15	Void	0.0	1.025	0.0	17.24	-0.06	0.84	0
VS-CH1	Void	0.0	1.025	0.0	73.30	0.00	2.56	0
VS-CH2P	Void	0.0	1.025	0.0	54.28	-4.15	1.47	0
VS-CH2S	Void	0.0	1.025	0.0	54.28	4.15	1.47	0
VS-CH3P	Void	0.0	1.025	0.0	31.34	-3.90	1.54	0
VS-CH3S	Void	0.0	1.025	0.0	31.34	3.90	1.54	0
VS117P	Void	0.0	1.025	0.0	83.12	-1.14	1.47	0
VS117S	Void	0.0	1.025	0.0	83.12	1.14	1.47	0
COFF#57	Coff.above HF.	0.0	1.025	0.0	41.90	0.00	7.39	0
CD-H2S	Void	0.0	1.025	0.0	56.97	7.35	8.01	0
CD-H2P	Void	0.0	1.025	0.0	56.97	-7.35	8.01	0
CD-H3S	Void	0.0	1.025	0.0	32.47	7.49	8.00	0
CD-H3P	Void	0.0	1.025	0.0	32.47	-7.49	8.00	0
PASP	Passage Way P	0.0	1.025	0.0	57.32	-6.63	6.30	0
PASS	Passage Way S	0.0	1.025	0.0	57.32	6.63	6.30	0
CD-H1C	Void	0.0	1.025	0.0	75.97	0.00	8.14	0
-----								
SUBTOTAL		0.0			0.00	0.00	0.00	0
CONTENTS : WB=Water Ballast (RHO=1.025)								
FPT	01 Fore Peak	0.0	1.025	0.0	86.58	0.00	5.75	0
WBT1P	WB02.P	0.0	1.025	0.0	72.06	-3.32	1.08	0
WBT1S	WB03.S	0.0	1.025	0.0	72.06	3.32	1.08	0
WBT2P	WB04.P	0.0	1.025	0.0	59.57	-6.88	2.06	0
WBT2S	WB05.S	0.0	1.025	0.0	59.57	6.88	2.06	0
WBT3P	WB06.P	0.0	1.025	0.0	46.80	-6.92	2.04	0
WBT3S	WB07.S	0.0	1.025	0.0	46.80	6.92	2.04	0
WBT4P	WB08.P	0.0	1.025	0.0	32.13	-6.86	2.06	0
WBT4S	WB09.S	0.0	1.025	0.0	32.13	6.86	2.06	0
WBT5P	WB10.P	2.3	1.025	2.4	74.22	-4.91	2.04	102
WBT5S	WB11.S	2.3	1.025	2.3	74.22	4.91	2.04	108
-----								
SUBTOTAL		4.7			74.22	-0.00	2.04	210
-----								
TOTAL		5393.0			48.60	0.06	5.38	464



## STABILITY SUMMARY

=====

## CRITERIA LIST

Environment: INTACT  
Criteria group: CR\_I Defaults

## LOADING CONDITION ER#GROUNDING08#1-TMP, Cond.5 Full.Arr

Heel (deg)	0.8	5.0	10.0	20.0	30.0	40.0	45.0
KN (m)	0.106	0.674	1.291	2.453	3.532	4.418	4.787
dGZ (m)	0.001	0.003	0.006	0.010	0.014	0.018	0.020
GZ (m)	0.03	0.18	0.30	0.51	0.69	0.76	0.77
e(phi) (mrad)	0.000	0.008	0.029	0.100	0.206	0.335	0.402

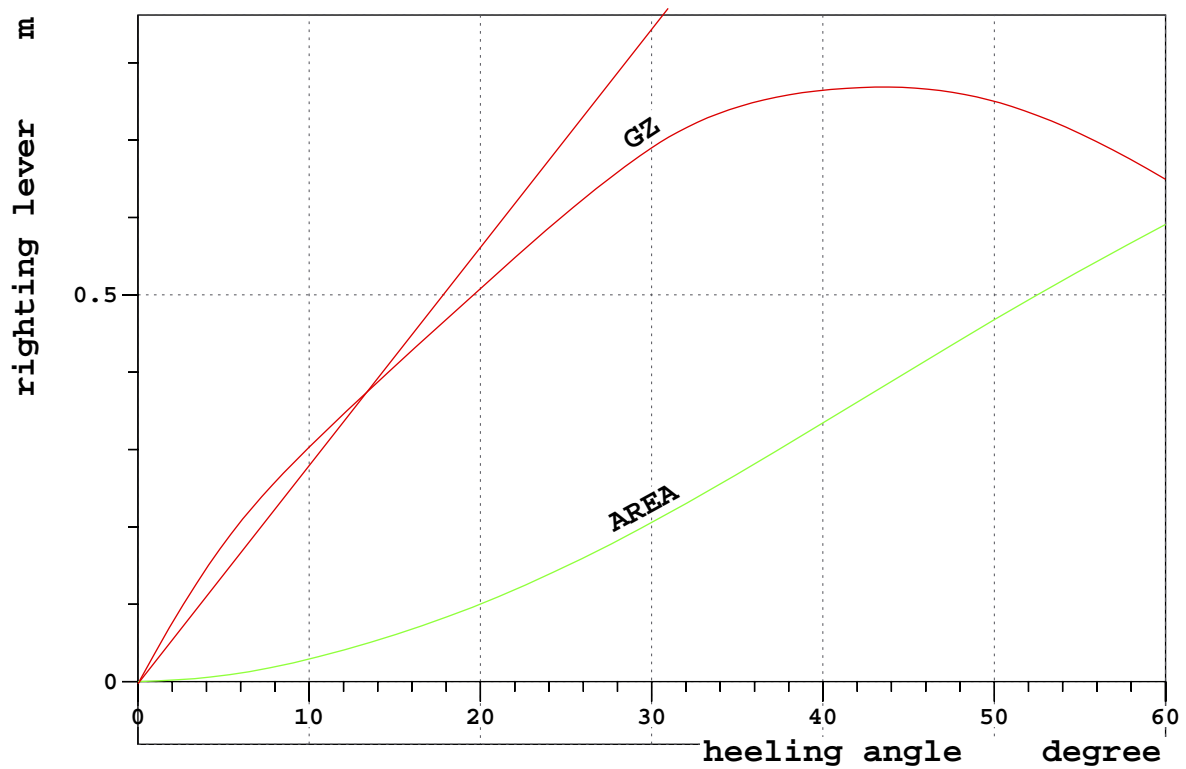





DNV

# DNV Emergency Response Service

ANNEX C

2009-03-23

17:38

Page 7

DNV.ID26559

CRETE CEMENT

## STRENGTH SUMMARY

=====

LOADING CONDITION ER#GROUNDING08#1-TMP, Cond.5 Full.Arr

		POSITION:	X	FRAME
SHEAR FORCE (MIN)	-186.9 t		23.0 m	32
SHEAR FORCE (MAX)	334.3 t		10.1 m	14
MAX. REL. SHEAR FORCE	54.1 %		10.1 m	14
SAGGING MOMENT	-6.8 tm		-5.1 m	-12
HOGGING MOMENT	4559.7 tm		20.5 m	29
MAX. REL. SAGGING MOMENT	-			
MAX. REL. HOGGING MOMENT	68.4 %		15.1 m	21

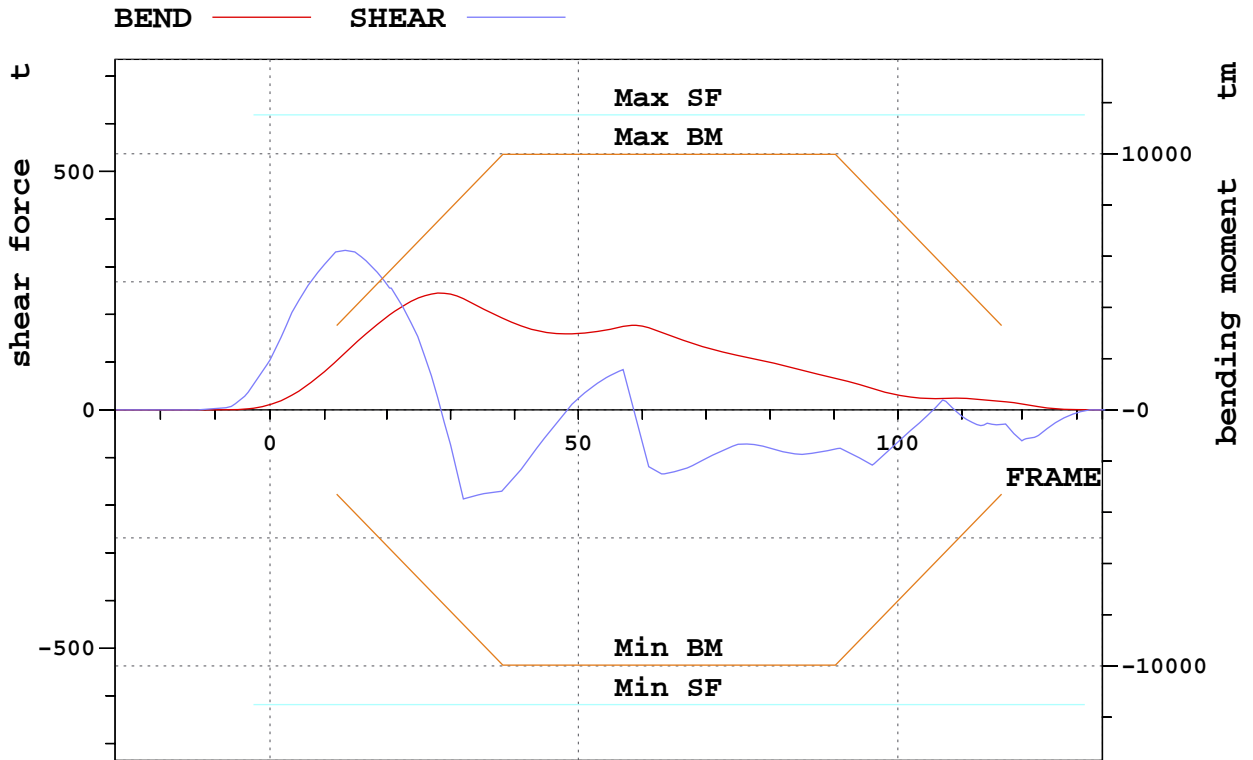



## CONDITION SUMMARY: DAMAGED CONDITION

=====

Scenario: GROUNDING08

Condition: Damage case 2

## Description note:

## Damaged compartments

FPT, DBWBT1P&amp;S, Double bottom tunnel, Bow thruster

Void under CH2P&amp;S, Void under CH3P&amp;S, ERS

## FLOATING CONDITION (ACTUAL)

Draft FP	7.89 m	KMT	7.328 m	Strength limits SEA	
Draft M	8.58 m	KG	5.656 m	SFmax	27.6 %
Draft AP	9.26 m	FSC	0.057 m	BMmax	40.9 %
		GMact	2.037 m	Outflow	0.0 t
Trim (aft+)	1.38 m	KGint	5.713 m	Sea Ingr.	2268.0 t
Heel (SB+)	0.96 deg			Gro Force	0.0 t

## INTACT DETAILS

## LOADS

Item	Weight (t)	L.C.G. (m)	T.C.G. (m)	V.C.G. (m)	Frs.mom. (tm)
Bulk cargo	5003.3	50.25	-0.00	5.50	0.0
Water Ballast	4.7	74.22	-0.00	2.04	210.2
Fresh Water	88.7	11.52	-0.26	4.32	18.4
Heavy Fuel Oil	108.5	36.52	-0.92	2.74	213.6
Diesel Oil	19.0	16.35	-3.05	0.57	18.0
Lubricating Oil	12.8	18.62	-1.99	3.49	3.5
MISCELLANEOUS	32.3	14.13	0.10	0.72	0.0
Constants	5.5	15.00	1.11	13.55	0.0
	118.1	35.97	4.29	5.63	0.0
Deadweight	5393.0	48.60	0.06	5.38	463.8
Lightweight	2748.6	39.74	-0.11	6.20	
Displacement (1.025 t/m3)	8141.7	45.60	-0.00	5.66	463.8



DNV

# DNV Emergency Response Service

ANNEX C

2009-03-23







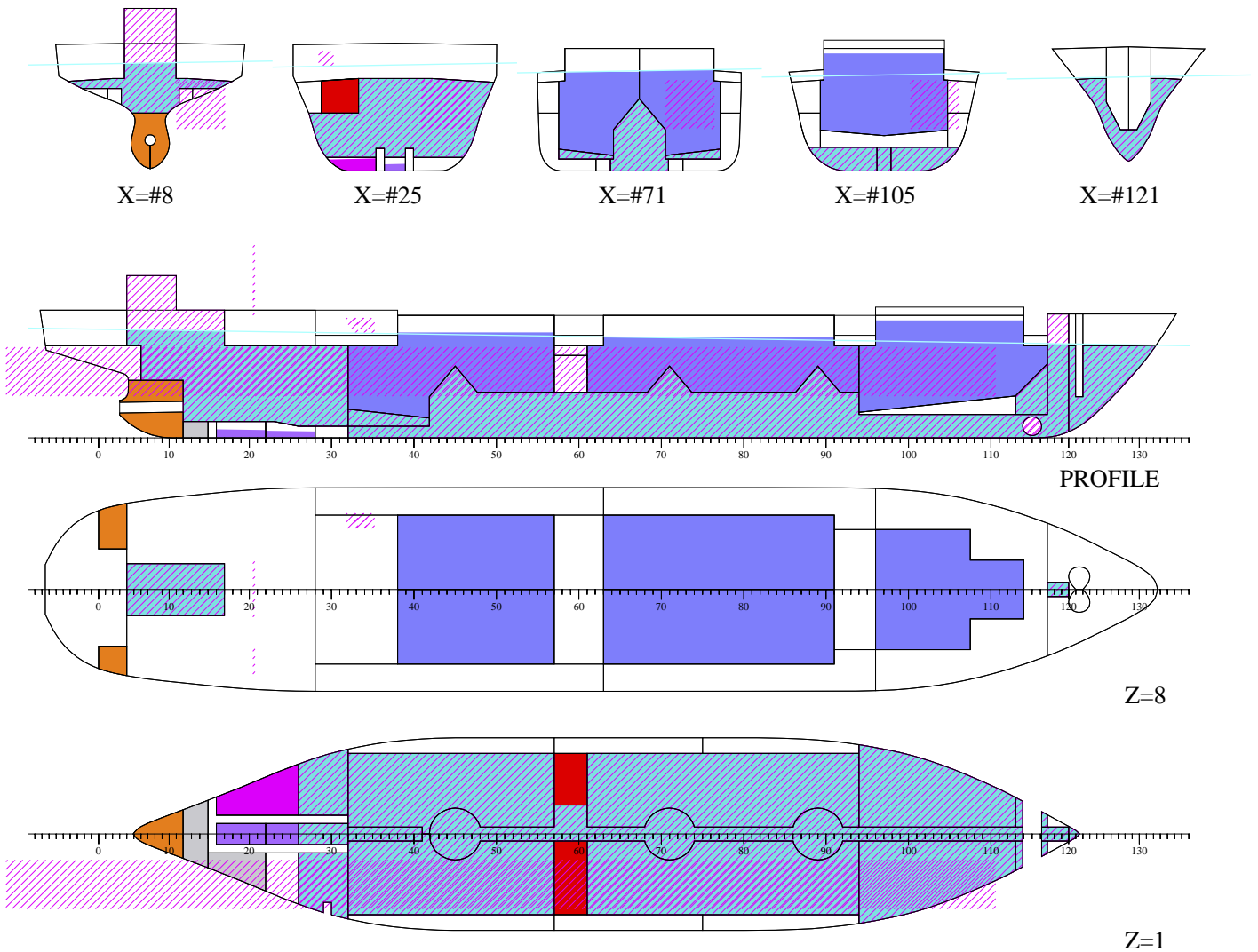

17:39

Page 2

DNV.ID26559

CRETE CEMENT



- |  |   |   |
|--|---|---|
|  Bulk cargo     |  Water Ballast |  Fresh Water     |
|  Heavy Fuel Oil |  Diesel Oil    |  Lubricating Oil |
|  MISCELLANEOUS  |  Constants     |   |



## COMPARTMENT LIST

ID	DES	MASS t	DENS t/m3	FILL %	LCG m	TCG m	VCG m	FRSM tm
CONTENTS : CAB=Bulk cargo (RHO=1.2)								
CH1	No1 cargo hold	996.5	1.200	95.0	72.64	0.00	6.38	0
CH2P	No2 C.Hold.P	1113.3	1.200	79.5	54.83	-3.52	5.17	0
CH2S	No2 C.Hold.S	1113.3	1.200	80.9	54.82	3.51	5.23	0
CH3P	No3 C.Hold.P	890.1	1.200	86.2	31.99	-3.44	5.38	0
CH3S	No3 C.Hold.S	890.1	1.200	86.2	31.99	3.44	5.38	0
SUBTOTAL		5003.3			50.25	-0.00	5.50	0

## CONTENTS : CHA=Chain Locker (RHO=1.025)

CLP	Chain Locker	0.0	1.025	0.0	85.10	-0.94	7.34	0
CLS	Chain Locker	0.0	1.025	0.0	85.10	0.94	7.34	0
SUBTOTAL		0.0			0.00	0.00	0.00	0

## CONTENTS : MASS=Constants (RHO=1)

CREW		4.5	1.000	0.0	15.00	0.00	14.00	0
PROV		1.0	1.000	0.0	15.00	6.11	11.50	0
SUBTOTAL		5.5			15.00	1.11	13.55	0

## CONTENTS : DO=Diesel Oil (RHO=0.85)

30DO1P	No30 DO.Stor..	0.0	0.850	0.0	0.00	0.00	0.00	0
31DO1S	No31 DO.Stor..	0.0	0.850	0.0	0.00	0.00	0.00	0
40DOSTP	No40 DO.Stor.P	19.0	0.850	79.2	16.35	-3.05	0.57	18
41DOS	No41 DO.Stor.S	0.0	0.850	0.0	0.00	0.00	0.00	0
42DOSTS	No42 DO.Stor.S	0.0	0.850	0.0	11.68	4.78	6.57	0
43DOSETP	No43 DO.Sett.P	0.0	0.850	0.0	10.88	-4.69	6.63	0
44DOSP	No44 DO.Serv.P	0.0	0.850	0.0	13.21	-4.95	6.48	0
45DOP	No45 DO.Serv.P	0.0	0.850	0.0	26.15	-5.74	9.65	0
SUBTOTAL		19.0			16.35	-3.05	0.57	18

## CONTENTS : FW=Fresh Water (RHO=1)

20FWT1P	No20 FWT.P	3.9	1.000	10.0	69.20	-6.13	3.07	1
21FWT1S	No21 FWT.S	3.9	1.000	10.0	69.20	6.13	3.07	1
22FWTP	No22 FWT.2P	15.4	1.000	50.0	3.06	-5.15	8.27	12
23DWTS	No23 FWT.2S	9.5	1.000	50.0	3.07	5.96	8.46	4
24APT	No24 Aft Peak	56.0	1.000	100.0	7.25	0.00	2.70	0



# DNV Emergency Response Service

ANNEX C

2009-03-23

17:39

Page 4



DNV.ID26559

CRETE CEMENT

SUBTOTAL		88.7			11.52	-0.26	4.32	18
----------	--	------	--	--	-------	-------	------	----

ID	DES	MASS t	DENS t/m3	FILL %	LCG m	TCG m	VCG m	FRSM tm
----	-----	-----------	--------------	-----------	----------	----------	----------	------------

CONTENTS : HFO=Heavy Fuel Oil (RHO=0.96)

32HFO2P	No32 HFO.St.2	6.5	0.960	10.3	36.78	-2.39	0.05	50
33HFO2S	No33 HFO.Stor.	6.5	0.960	9.6	37.14	2.33	0.05	55
34HFO3P	No34 HFO.Stor.	37.0	0.960	38.2	41.90	-3.72	2.21	54
35HFO3S	No35 HFO.Stor.	37.0	0.960	35.7	41.90	3.72	2.13	55
36FOSETP	No36 FO.Stl.P	0.0	0.960	0.0	16.07	-5.88	6.42	0
37FOS1P	No37 HFO.Serv.	8.6	0.960	100.0	18.80	-4.63	6.33	0
38FOS2P	No38 HFO.Serv.	12.9	0.960	100.0	17.05	-4.63	6.33	0
FOVS	No39 F.O.Over.	0.0	0.960	0.0	17.37	3.31	0.68	0
63FODRP	No63 Fo.Drain.	0.0	0.960	0.0	22.31	-4.58	0.53	0

SUBTOTAL		108.5			36.52	-0.92	2.74	214
----------	--	-------	--	--	-------	-------	------	-----

CONTENTS : LO=Lubricating Oil (RHO=0.9)

50RGLO	No50 RG.LO.P	0.0	0.900	0.0	7.25	-4.14	6.58	0
51DGLOP	No51 DG.LO.P	0.0	0.900	0.0	7.92	-2.99	6.20	0
52LOS	No52 LO.DG.S	0.0	0.900	0.0	7.92	2.99	6.20	0
53TCLOS	No53 TC L.O.S	0.0	0.900	0.0	7.25	4.14	6.58	0
54LOSTRS	No54 ME.LO.S	0.0	0.900	0.0	14.61	5.12	6.43	0
64LODRC	No64 LO.Drain	3.9	0.900	50.0	18.10	0.00	0.35	2
56WOC	No56 Waste.C	4.6	0.900	50.0	13.90	-0.00	0.35	2
57LUB.P		1.5	0.900	0.0	24.75	-5.84	9.56	0
58LUB.P		1.5	0.900	0.0	24.05	-5.84	9.56	0
59LUB.P		1.5	0.900	0.0	23.35	-5.84	9.56	0

SUBTOTAL		12.8			18.62	-1.99	3.49	4
----------	--	------	--	--	-------	-------	------	---

CONTENTS : MIS=MISCELLANEOUS (RHO=1)

60BT	No.60 Bilge T.	12.1	1.000	100.0	10.12	0.00	0.78	0
61SLUP	No61 Sludge.P	7.9	0.900	100.0	20.58	-3.79	0.53	0
62SEWS	No62 Sewage	12.3	1.000	100.0	13.96	2.69	0.79	0

SUBTOTAL		32.3			14.13	0.10	0.72	0
----------	--	------	--	--	-------	------	------	---

CONTENTS : MMA=Machinery Sp. (RHO=1)

ER	Engine Room	0.0	1.000	0.0	15.45	0.22	5.39	0
BTR	Bow.Thr.Rm	0.0	1.000	0.0	81.14	-0.00	3.14	0
SGR	Steer.Gear.Rm	0.0	1.000	0.0	0.61	0.19	9.37	0
TUNNEL	Void	0.0	1.000	0.0	52.08	-0.02	1.98	0
MACHAFT	Aft Machine R.	0.0	1.000	0.0	23.65	0.12	9.29	0
MACH-MID	Midship Machi.	0.0	1.000	0.0	42.60	0.00	9.10	0
MACH-FWD	Forward Deckh.	0.0	1.000	0.0	66.05	0.00	9.11	0

SUBTOTAL		0.0			0.00	0.00	0.00	0
----------	--	-----	--	--	------	------	------	---



# DNV Emergency Response Service

ANNEX C

2009-03-23

17:39

Page 5



DNV.ID26559

CRETE CEMENT

ID	DES	MASS t	DENS t/m3	FILL %	LCG m	TCG m	VCG m	FRSM tm
-----								
CONTENTS : STO=Stores (RHO=1)								
BSN	Bosun Store	0.0	1.000	0.0	86.64	0.00	9.28	0
CONTENTS : MASS= (RHO=0)								
(UNKNOWN_.		118.1	0.000	0.0	35.97	4.29	5.63	0
CONTENTS : VOID=Void (RHO=1.025)								
VSA	Void	0.0	1.025	0.0	13.03	0.00	9.27	0
VS#6	Void	0.0	1.025	0.0	2.78	0.13	7.10	0
CD#15	Void	0.0	1.025	0.0	17.24	-0.06	0.84	0
VS-CH1	Void	0.0	1.025	0.0	73.30	0.00	2.56	0
VS-CH2P	Void	0.0	1.025	0.0	54.28	-4.15	1.47	0
VS-CH2S	Void	0.0	1.025	0.0	54.28	4.15	1.47	0
VS-CH3P	Void	0.0	1.025	0.0	31.34	-3.90	1.54	0
VS-CH3S	Void	0.0	1.025	0.0	31.34	3.90	1.54	0
VS117P	Void	0.0	1.025	0.0	83.12	-1.14	1.47	0
VS117S	Void	0.0	1.025	0.0	83.12	1.14	1.47	0
COFF#57	Coff.above HF.	0.0	1.025	0.0	41.90	0.00	7.39	0
CD-H2S	Void	0.0	1.025	0.0	56.97	7.35	8.01	0
CD-H2P	Void	0.0	1.025	0.0	56.97	-7.35	8.01	0
CD-H3S	Void	0.0	1.025	0.0	32.47	7.49	8.00	0
CD-H3P	Void	0.0	1.025	0.0	32.47	-7.49	8.00	0
PASP	Passage Way P	0.0	1.025	0.0	57.32	-6.63	6.30	0
PASS	Passage Way S	0.0	1.025	0.0	57.32	6.63	6.30	0
CD-H1C	Void	0.0	1.025	0.0	75.97	0.00	8.14	0
-----								
SUBTOTAL		0.0			0.00	0.00	0.00	0
CONTENTS : WB=Water Ballast (RHO=1.025)								
FPT	01 Fore Peak	0.0	1.025	0.0	86.58	0.00	5.75	0
WBT1P	WB02.P	0.0	1.025	0.0	72.06	-3.32	1.08	0
WBT1S	WB03.S	0.0	1.025	0.0	72.06	3.32	1.08	0
WBT2P	WB04.P	0.0	1.025	0.0	59.57	-6.88	2.06	0
WBT2S	WB05.S	0.0	1.025	0.0	59.57	6.88	2.06	0
WBT3P	WB06.P	0.0	1.025	0.0	46.80	-6.92	2.04	0
WBT3S	WB07.S	0.0	1.025	0.0	46.80	6.92	2.04	0
WBT4P	WB08.P	0.0	1.025	0.0	32.13	-6.86	2.06	0
WBT4S	WB09.S	0.0	1.025	0.0	32.13	6.86	2.06	0
WBT5P	WB10.P	2.3	1.025	2.4	74.22	-4.91	2.04	102
WBT5S	WB11.S	2.3	1.025	2.3	74.22	4.91	2.04	108
-----								
SUBTOTAL		4.7			74.22	-0.00	2.04	210
-----								
TOTAL		5393.0			48.60	0.06	5.38	464



STABILITY SUMMARY

=====

CRITERIA LIST

Environment: INTACT  
Criteria group: CR\_I Defaults

LOADING CONDITION ER#GROUNDING08#1-TMP, Cond.5 Full.Arr

Heel (deg)	0.8	5.0	10.0	20.0	30.0	40.0	45.0
KN (m)	0.074	0.642	1.317	2.536	3.520	4.329	4.674
dGZ (m)	0.001	0.004	0.006	0.010	0.014	0.019	0.021
GZ (m)	-0.01	0.15	0.33	0.59	0.68	0.68	0.65
e(phi) (mrad)	-0.000	0.005	0.026	0.109	0.222	0.341	0.399

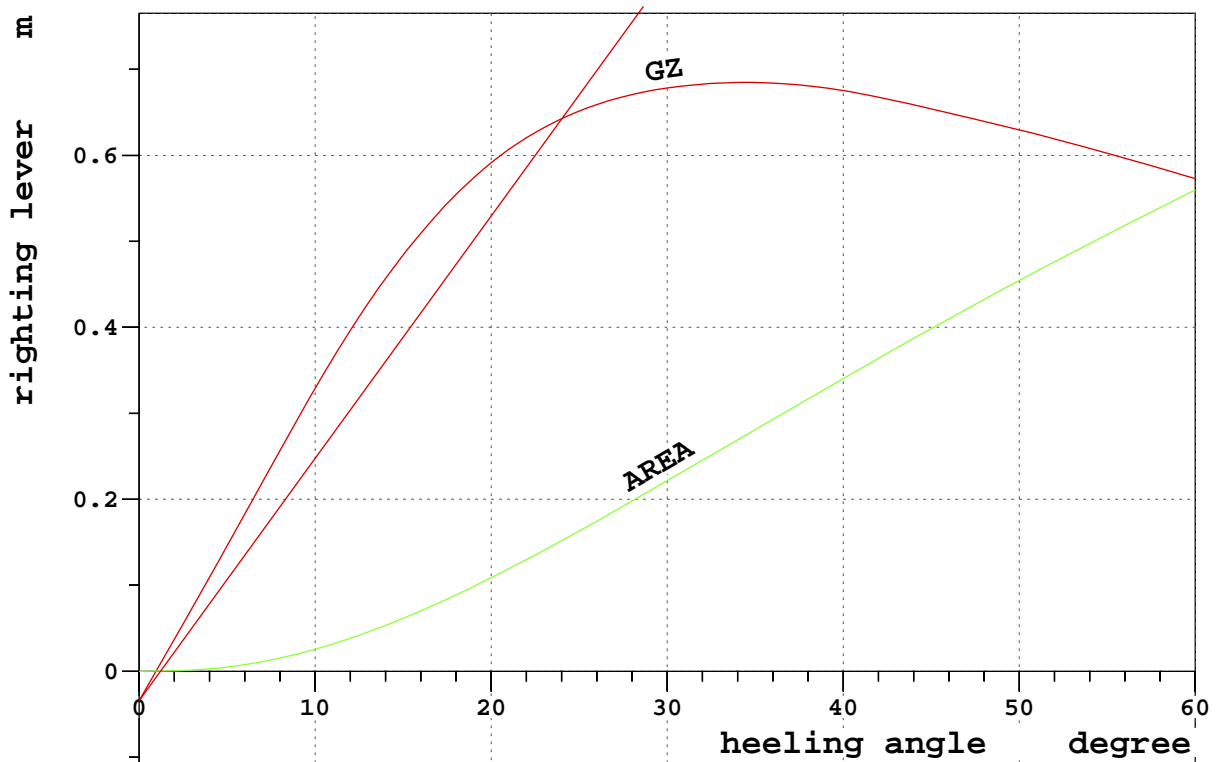



## STRENGTH SUMMARY

=====

LOADING CONDITION ER#GROUNDING08#1-TMP, Cond.5 Full.Arr

		POSITION:	X	FRAME
SHEAR FORCE (MIN)	-138.2 t		67.8 m	96
SHEAR FORCE (MAX)	170.8 t		40.5 m	57
MAX. REL. SHEAR FORCE	27.6 %		40.5 m	57
SAGGING MOMENT	-3.0 tm		91.6 m	132
HOGGING MOMENT	4080.0 tm		42.6 m	60
MAX. REL. SAGGING MOMENT	-			
MAX. REL. HOGGING MOMENT	40.9 %		42.6 m	60

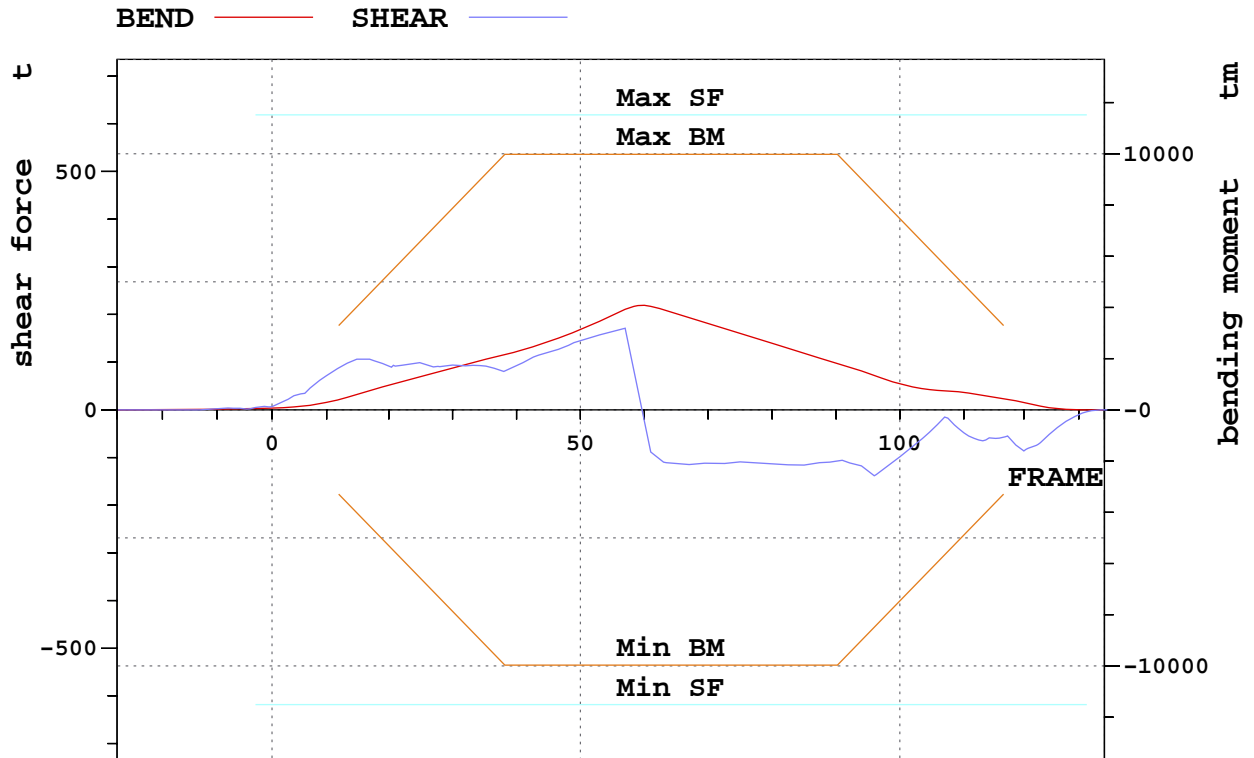





## CONDITION SUMMARY: DAMAGED CONDITION

=====

Scenario: GROUNDING08

Condition: Damage case 2A

## Description note:

## Damaged compartments

Same as Damage case 2 + progressive flooding to  
 poop deck compartments and compressor room on main deck

## FLOATING CONDITION (ACTUAL)

Draft FP	0.00 m	KMT	7.328 m	Strength limits SEA	
Draft M	0.00 m	KG	5.656 m	SFmax	110.9 %
Draft AP	0.00 m	FSC	0.057 m	BMmax	210.3 %
		GMact	-99998 m	Outflow	0.0 t
Trim (aft+)	0.00 m	KGint	5.713 m	Sea Ingr.	3289.9 t
Heel (SB+)	171.89 deg			Gro Force	0.0 t

## INTACT DETAILS

## LOADS

Item	Weight (t)	L.C.G. (m)	T.C.G. (m)	V.C.G. (m)	Frs.mom. (tm)
Bulk cargo	5003.3	50.25	-0.00	5.50	0.0
Water Ballast	4.7	74.22	-0.00	2.04	210.2
Fresh Water	88.7	11.52	-0.26	4.32	18.4
Heavy Fuel Oil	108.5	36.52	-0.92	2.74	213.6
Diesel Oil	19.0	16.35	-3.05	0.57	18.0
Lubricating Oil	12.8	18.62	-1.99	3.49	3.5
MISCELLANEOUS	32.3	14.13	0.10	0.72	0.0
Constants	5.5	15.00	1.11	13.55	0.0
	118.1	35.97	4.29	5.63	0.0
Deadweight	5393.0	48.60	0.06	5.38	463.8
Lightweight	2748.6	39.74	-0.11	6.20	
Displacement (1.025 t/m3)	8141.7	45.60	-0.00	5.66	463.8



DNV

# DNV Emergency Response Service

ANNEX C

2009-03-23

17:42

Page 2

DNV.ID26559

CRETE CEMENT

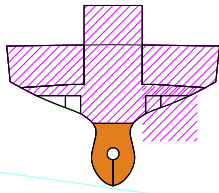

X=#8

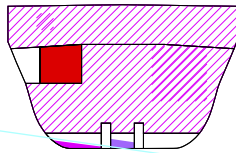

X=#25

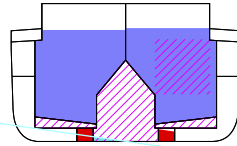

X=#71

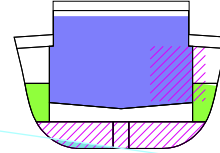

X=#105

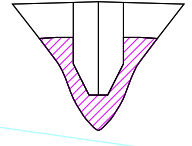

X=#121

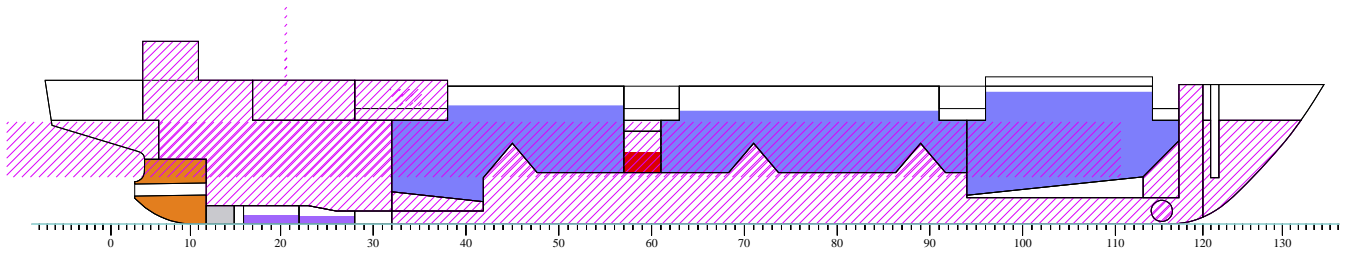

PROFILE

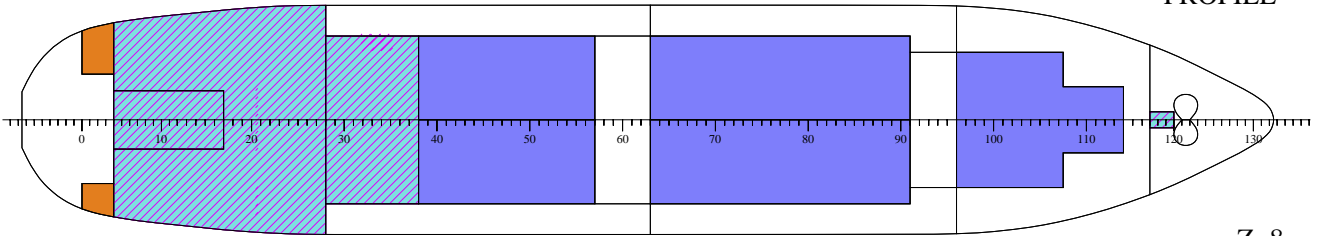

Z=8

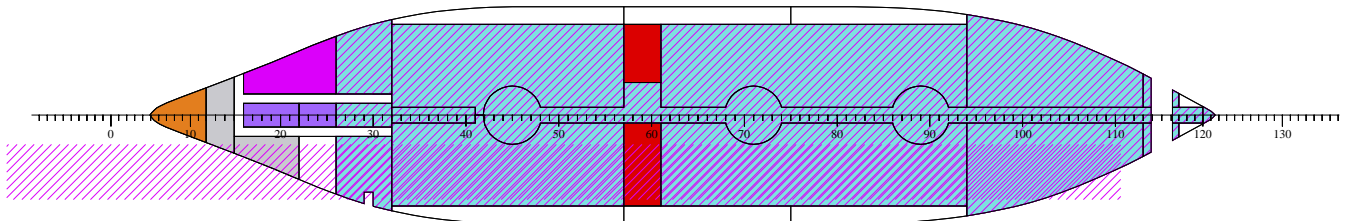

Z=1

- |                |               |                 |
|----------------|---------------|-----------------|
| Bulk cargo     | Water Ballast | Fresh Water     |
| Heavy Fuel Oil | Diesel Oil    | Lubricating Oil |
| MISCELLANE     | Constants     |                 |



## COMPARTMENT LIST

ID	DES	MASS t	DENS t/m3	FILL %	LCG m	TCG m	VCG m	FRSM tm
CONTENTS : CAB=Bulk cargo (RHO=1.2)								
CH1	No1 cargo hold	996.5	1.200	95.0	72.64	0.00	6.38	0
CH2P	No2 C.Hold.P	1113.3	1.200	79.5	54.83	-3.52	5.17	0
CH2S	No2 C.Hold.S	1113.3	1.200	80.9	54.82	3.51	5.23	0
CH3P	No3 C.Hold.P	890.1	1.200	86.2	31.99	-3.44	5.38	0
CH3S	No3 C.Hold.S	890.1	1.200	86.2	31.99	3.44	5.38	0
SUBTOTAL		5003.3			50.25	-0.00	5.50	0

## CONTENTS : CHA=Chain Locker (RHO=1.025)

CLP	Chain Locker	0.0	1.025	0.0	85.10	-0.94	7.34	0
CLS	Chain Locker	0.0	1.025	0.0	85.10	0.94	7.34	0
SUBTOTAL		0.0			0.00	0.00	0.00	0

## CONTENTS : MASS=Constants (RHO=1)

CREW		4.5	1.000	0.0	15.00	0.00	14.00	0
PROV		1.0	1.000	0.0	15.00	6.11	11.50	0
SUBTOTAL		5.5			15.00	1.11	13.55	0

## CONTENTS : DO=Diesel Oil (RHO=0.85)

30DO1P	No30 DO.Stor..	0.0	0.850	0.0	0.00	0.00	0.00	0
31DO1S	No31 DO.Stor..	0.0	0.850	0.0	0.00	0.00	0.00	0
40DOSTP	No40 DO.Stor.P	19.0	0.850	79.2	16.35	-3.05	0.57	18
41DOS	No41 DO.Stor.S	0.0	0.850	0.0	0.00	0.00	0.00	0
42DOSTS	No42 DO.Stor.S	0.0	0.850	0.0	11.68	4.78	6.57	0
43DOSETP	No43 DO.Sett.P	0.0	0.850	0.0	10.88	-4.69	6.63	0
44DOSP	No44 DO.Serv.P	0.0	0.850	0.0	13.21	-4.95	6.48	0
45DOP	No45 DO.Serv.P	0.0	0.850	0.0	26.15	-5.74	9.65	0
SUBTOTAL		19.0			16.35	-3.05	0.57	18

## CONTENTS : FW=Fresh Water (RHO=1)

20FWT1P	No20 FWT.P	3.9	1.000	10.0	69.20	-6.13	3.07	1
21FWT1S	No21 FWT.S	3.9	1.000	10.0	69.20	6.13	3.07	1
22FWTP	No22 FWT.2P	15.4	1.000	50.0	3.06	-5.15	8.27	12
23DWTS	No23 FWT.2S	9.5	1.000	50.0	3.07	5.96	8.46	4
24APT	No24 Aft Peak	56.0	1.000	100.0	7.25	0.00	2.70	0



# DNV Emergency Response Service

ANNEX C

2009-03-23

17:42

Page 4



DNV.ID26559

CRETE CEMENT

SUBTOTAL		88.7			11.52	-0.26	4.32	18
----------	--	------	--	--	-------	-------	------	----

ID	DES	MASS t	DENS t/m3	FILL %	LCG m	TCG m	VCG m	FRSM tm
----	-----	-----------	--------------	-----------	----------	----------	----------	------------

CONTENTS : HFO=Heavy Fuel Oil (RHO=0.96)

32HFO2P	No32 HFO.St.2	6.5	0.960	10.3	36.78	-2.39	0.05	50
33HFO2S	No33 HFO.Stor.	6.5	0.960	9.6	37.14	2.33	0.05	55
34HFO3P	No34 HFO.Stor.	37.0	0.960	38.2	41.90	-3.72	2.21	54
35HFO3S	No35 HFO.Stor.	37.0	0.960	35.7	41.90	3.72	2.13	55
36FOSETP	No36 FO.Stl.P	0.0	0.960	0.0	16.07	-5.88	6.42	0
37FOS1P	No37 HFO.Serv.	8.6	0.960	100.0	18.80	-4.63	6.33	0
38FOS2P	No38 HFO.Serv.	12.9	0.960	100.0	17.05	-4.63	6.33	0
FOVS	No39 F.O.Over.	0.0	0.960	0.0	17.37	3.31	0.68	0
63FODRP	No63 Fo.Drain.	0.0	0.960	0.0	22.31	-4.58	0.53	0

SUBTOTAL		108.5			36.52	-0.92	2.74	214
----------	--	-------	--	--	-------	-------	------	-----

CONTENTS : LO=Lubricating Oil (RHO=0.9)

50RGLO	No50 RG.LO.P	0.0	0.900	0.0	7.25	-4.14	6.58	0
51DGLOP	No51 DG.LO.P	0.0	0.900	0.0	7.92	-2.99	6.20	0
52LOS	No52 LO.DG.S	0.0	0.900	0.0	7.92	2.99	6.20	0
53TCLOS	No53 TC L.O.S	0.0	0.900	0.0	7.25	4.14	6.58	0
54LOSTRS	No54 ME.LO.S	0.0	0.900	0.0	14.61	5.12	6.43	0
64LODRC	No64 LO.Drain	3.9	0.900	50.0	18.10	0.00	0.35	2
56WOC	No56 Waste.C	4.6	0.900	50.0	13.90	-0.00	0.35	2
57LUB.P		1.5	0.900	0.0	24.75	-5.84	9.56	0
58LUB.P		1.5	0.900	0.0	24.05	-5.84	9.56	0
59LUB.P		1.5	0.900	0.0	23.35	-5.84	9.56	0

SUBTOTAL		12.8			18.62	-1.99	3.49	4
----------	--	------	--	--	-------	-------	------	---

CONTENTS : MIS=MISCELLANEOUS (RHO=1)

60BT	No.60 Bilge T.	12.1	1.000	100.0	10.12	0.00	0.78	0
61SLUP	No61 Sludge.P	7.9	0.900	100.0	20.58	-3.79	0.53	0
62SEWS	No62 Sewage	12.3	1.000	100.0	13.96	2.69	0.79	0

SUBTOTAL		32.3			14.13	0.10	0.72	0
----------	--	------	--	--	-------	------	------	---

CONTENTS : MMA=Machinery Sp. (RHO=1)

ER	Engine Room	0.0	1.000	0.0	15.45	0.22	5.39	0
BTR	Bow.Thr.Rm	0.0	1.000	0.0	81.14	-0.00	3.14	0
SGR	Steer.Gear.Rm	0.0	1.000	0.0	0.61	0.19	9.37	0
TUNNEL	Void	0.0	1.000	0.0	52.08	-0.02	1.98	0
MACHAFT	Aft Machine R.	0.0	1.000	0.0	23.65	0.12	9.29	0
MACH-MID	Midship Machi.	0.0	1.000	0.0	42.60	0.00	9.10	0
MACH-FWD	Forward Deckh.	0.0	1.000	0.0	66.05	0.00	9.11	0

SUBTOTAL		0.0			0.00	0.00	0.00	0
----------	--	-----	--	--	------	------	------	---



# DNV Emergency Response Service

ANNEX C

2009-03-23

17:42

Page 5



DNV.ID26559

CRETE CEMENT

ID	DES	MASS t	DENS t/m3	FILL %	LCG m	TCG m	VCG m	FRSM tm
-----								
CONTENTS : STO=Stores (RHO=1)								
BSN	Bosun Store	0.0	1.000	0.0	86.64	0.00	9.28	0
CONTENTS : MASS= (RHO=0)								
(UNKNOWN_.		118.1	0.000	0.0	35.97	4.29	5.63	0
CONTENTS : VOID=Void (RHO=1.025)								
VSA	Void	0.0	1.025	0.0	13.03	0.00	9.27	0
VS#6	Void	0.0	1.025	0.0	2.78	0.13	7.10	0
CD#15	Void	0.0	1.025	0.0	17.24	-0.06	0.84	0
VS-CH1	Void	0.0	1.025	0.0	73.30	0.00	2.56	0
VS-CH2P	Void	0.0	1.025	0.0	54.28	-4.15	1.47	0
VS-CH2S	Void	0.0	1.025	0.0	54.28	4.15	1.47	0
VS-CH3P	Void	0.0	1.025	0.0	31.34	-3.90	1.54	0
VS-CH3S	Void	0.0	1.025	0.0	31.34	3.90	1.54	0
VS117P	Void	0.0	1.025	0.0	83.12	-1.14	1.47	0
VS117S	Void	0.0	1.025	0.0	83.12	1.14	1.47	0
COFF#57	Coff.above HF.	0.0	1.025	0.0	41.90	0.00	7.39	0
CD-H2S	Void	0.0	1.025	0.0	56.97	7.35	8.01	0
CD-H2P	Void	0.0	1.025	0.0	56.97	-7.35	8.01	0
CD-H3S	Void	0.0	1.025	0.0	32.47	7.49	8.00	0
CD-H3P	Void	0.0	1.025	0.0	32.47	-7.49	8.00	0
PASP	Passage Way P	0.0	1.025	0.0	57.32	-6.63	6.30	0
PASS	Passage Way S	0.0	1.025	0.0	57.32	6.63	6.30	0
CD-H1C	Void	0.0	1.025	0.0	75.97	0.00	8.14	0
-----								
SUBTOTAL		0.0			0.00	0.00	0.00	0
CONTENTS : WB=Water Ballast (RHO=1.025)								
FPT	01 Fore Peak	0.0	1.025	0.0	86.58	0.00	5.75	0
WBT1P	WB02.P	0.0	1.025	0.0	72.06	-3.32	1.08	0
WBT1S	WB03.S	0.0	1.025	0.0	72.06	3.32	1.08	0
WBT2P	WB04.P	0.0	1.025	0.0	59.57	-6.88	2.06	0
WBT2S	WB05.S	0.0	1.025	0.0	59.57	6.88	2.06	0
WBT3P	WB06.P	0.0	1.025	0.0	46.80	-6.92	2.04	0
WBT3S	WB07.S	0.0	1.025	0.0	46.80	6.92	2.04	0
WBT4P	WB08.P	0.0	1.025	0.0	32.13	-6.86	2.06	0
WBT4S	WB09.S	0.0	1.025	0.0	32.13	6.86	2.06	0
WBT5P	WB10.P	2.3	1.025	2.4	74.22	-4.91	2.04	102
WBT5S	WB11.S	2.3	1.025	2.3	74.22	4.91	2.04	108
-----								
SUBTOTAL		4.7			74.22	-0.00	2.04	210
-----								
TOTAL		5393.0			48.60	0.06	5.38	464



DNV

# DNV Emergency Response Service

ANNEX C

2009-03-23

17:42

Page 6

DNV.ID26559

CRETE CEMENT

## STABILITY SUMMARY

=====

### CRITERIA LIST

Environment: INTACT  
Criteria group: CR\_I Defaults

LOADING CONDITION ER#GROUNDING08#1-TMP, Cond.5 Full.Arr

Heel	(deg)	0.8	5.0	10.0	20.0	30.0	40.0	45.0
KN	(m)	0.039	0.445					
dGZ	(m)	0.000	0.002					
GZ	(m)	-0.04	-0.05					
e(phi)	(mrad)	-0.001	-0.004	-0.004	-0.004	-0.004	-0.004	-0.004

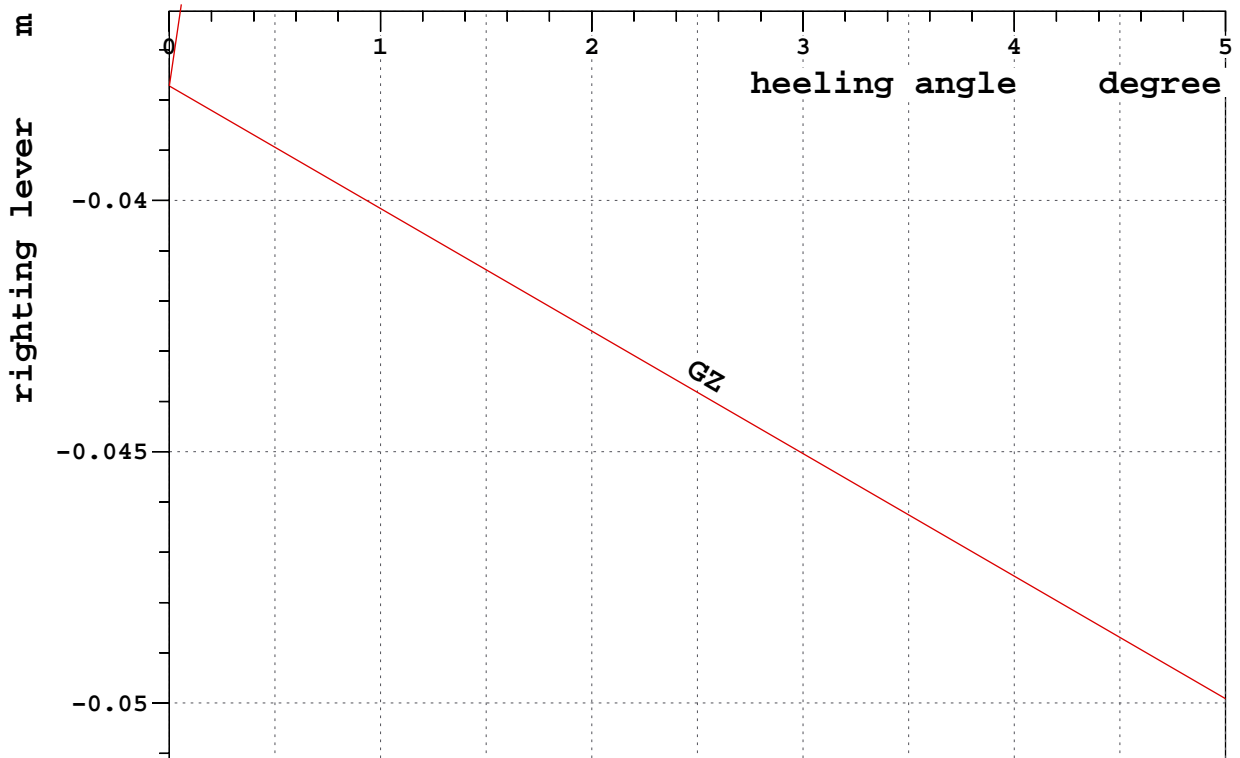



### STRENGTH SUMMARY

=====

LOADING CONDITION ER#GROUNDING08#1-TMP, Cond.5 Full.Arr

		POSITION:	X	FRAME
SHEAR FORCE (MIN)	-415.7 t		64.3 m	91
SHEAR FORCE (MAX)	494.7 t		27.2 m	38
MAX. REL. SHEAR FORCE	80.0 %		27.2 m	38
SAGGING MOMENT	-552.3 tm		7.1 m	9
HOGGING MOMENT	10130.0 tm		45.5 m	64
MAX. REL. SAGGING MOMENT	14.7 %		9.1 m	12
MAX. REL. HOGGING MOMENT	101.6 %		45.5 m	64

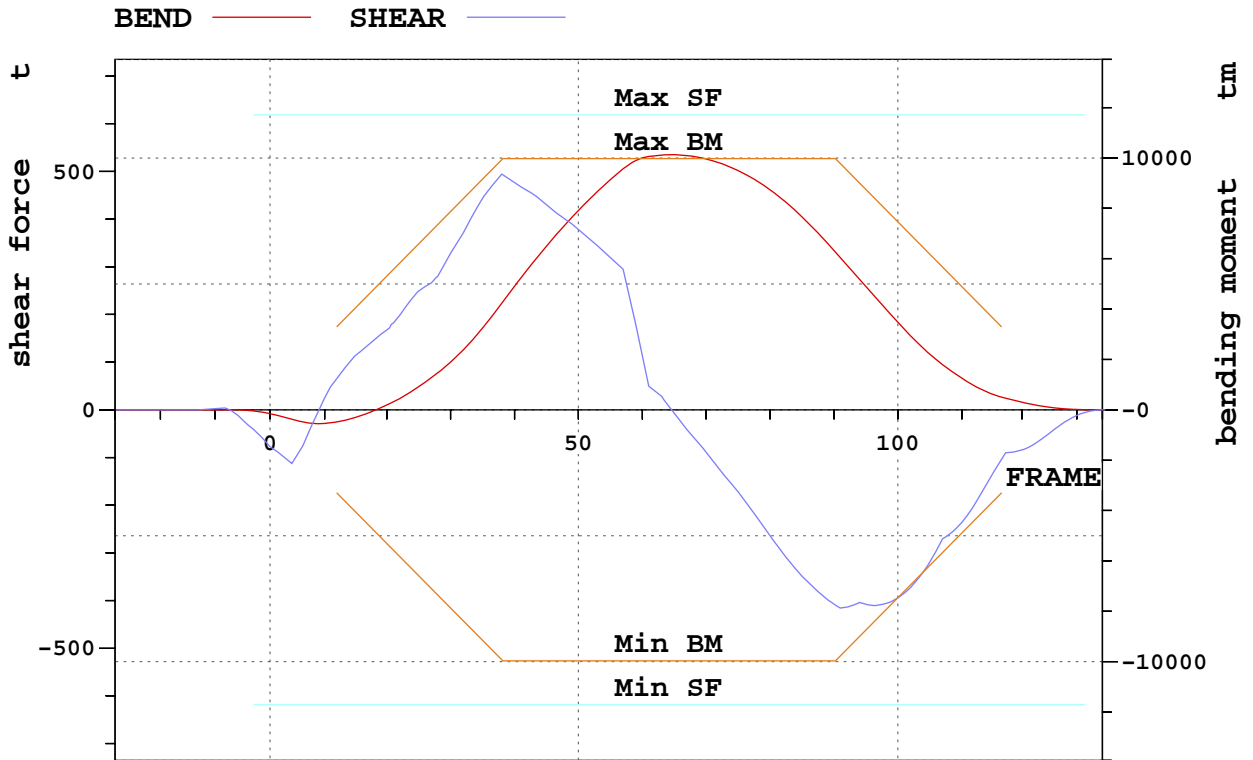



DNV

# DNV Emergency Response Service

ANNEX C

2009-03-23

17:45

Page 1

DNV.ID26559

CRETE CEMENT

## CONDITION SUMMARY: DAMAGED CONDITION

=====

Scenario: GROUNDING08

Condition: Damage case 3

### Description note:

Damaged compartments.

FPT, DBWBT1P&S, Double bottom tunnel, Bow thruster

void under CH2P&S, void under CH3P&S, ER, void under CH1

## FLOATING CONDITION (ACTUAL)

Draft FP	8.19 m	KMT	7.328 m	Strength limits SEA	
Draft M	8.68 m	KG	5.656 m	SFmax	29.3 %
Draft AP	9.17 m	FSC	0.057 m	BMmax	45.3 %
		GMact	1.743 m	Outflow	0.0 t
Trim (aft+)	0.98 m	KGint	5.713 m	Sea Ingr.	2387.7 t
Heel (SB+)	1.08 deg			Gro Force	0.0 t

## INTACT DETAILS

### LOADS

Item	Weight (t)	L.C.G. (m)	T.C.G. (m)	V.C.G. (m)	Frs.mom. (tm)
Bulk cargo	5003.3	50.25	-0.00	5.50	0.0
Water Ballast	4.7	74.22	-0.00	2.04	210.2
Fresh Water	88.7	11.52	-0.26	4.32	18.4
Heavy Fuel Oil	108.5	36.52	-0.92	2.74	213.6
Diesel Oil	19.0	16.35	-3.05	0.57	18.0
Lubricating Oil	12.8	18.62	-1.99	3.49	3.5
MISCELLANEOUS	32.3	14.13	0.10	0.72	0.0
Constants	5.5	15.00	1.11	13.55	0.0
	118.1	35.97	4.29	5.63	0.0
Deadweight	5393.0	48.60	0.06	5.38	463.8
Lightweight	2748.6	39.74	-0.11	6.20	
Displacement (1.025 t/m3)	8141.7	45.60	-0.00	5.66	463.8





DNV

# DNV Emergency Response Service

ANNEX C

2009-03-23

17:45

Page 2

DNV.ID26559

CRETE CEMENT

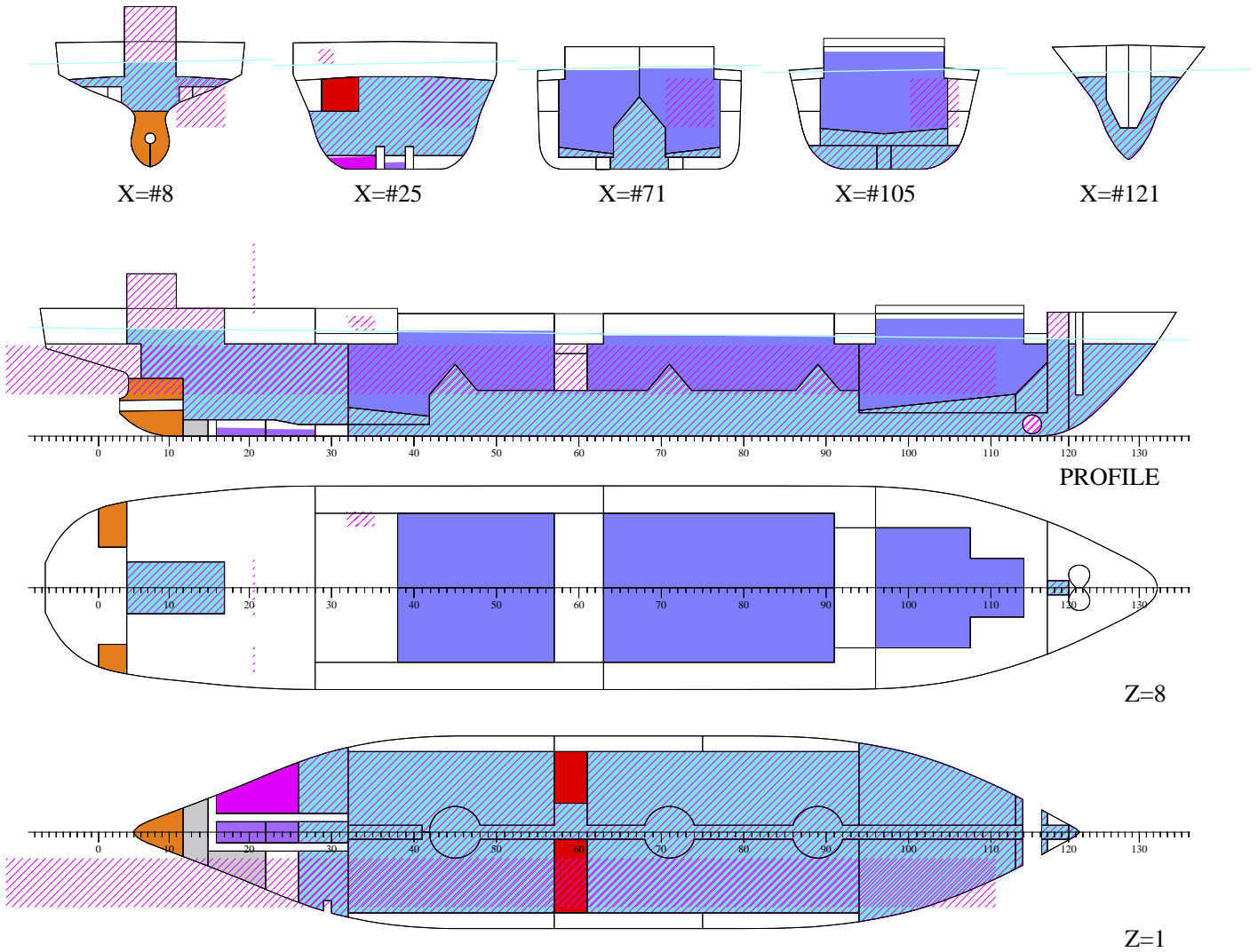

- |                |               |                 |
|----------------|---------------|-----------------|
| Bulk cargo     | Water Ballast | Fresh Water     |
| Heavy Fuel Oil | Diesel Oil    | Lubricating Oil |
| MISCELLANE     | Constants     |                 |



## COMPARTMENT LIST

ID	DES	MASS t	DENS t/m3	FILL %	LCG m	TCG m	VCG m	FRSM tm
CONTENTS : CAB=Bulk cargo (RHO=1.2)								
CH1	No1 cargo hold	996.5	1.200	95.0	72.64	0.00	6.38	0
CH2P	No2 C.Hold.P	1113.3	1.200	79.5	54.83	-3.52	5.17	0
CH2S	No2 C.Hold.S	1113.3	1.200	80.9	54.82	3.51	5.23	0
CH3P	No3 C.Hold.P	890.1	1.200	86.2	31.99	-3.44	5.38	0
CH3S	No3 C.Hold.S	890.1	1.200	86.2	31.99	3.44	5.38	0
SUBTOTAL		5003.3			50.25	-0.00	5.50	0

## CONTENTS : CHA=Chain Locker (RHO=1.025)

CLP	Chain Locker	0.0	1.025	0.0	85.10	-0.94	7.34	0
CLS	Chain Locker	0.0	1.025	0.0	85.10	0.94	7.34	0
SUBTOTAL		0.0			0.00	0.00	0.00	0

## CONTENTS : MASS=Constants (RHO=1)

CREW		4.5	1.000	0.0	15.00	0.00	14.00	0
PROV		1.0	1.000	0.0	15.00	6.11	11.50	0
SUBTOTAL		5.5			15.00	1.11	13.55	0

## CONTENTS : DO=Diesel Oil (RHO=0.85)

30DO1P	No30 DO.Stor..	0.0	0.850	0.0	0.00	0.00	0.00	0
31DO1S	No31 DO.Stor..	0.0	0.850	0.0	0.00	0.00	0.00	0
40DOSTP	No40 DO.Stor.P	19.0	0.850	79.2	16.35	-3.05	0.57	18
41DOS	No41 DO.Stor.S	0.0	0.850	0.0	0.00	0.00	0.00	0
42DOSTS	No42 DO.Stor.S	0.0	0.850	0.0	11.68	4.78	6.57	0
43DOSETP	No43 DO.Sett.P	0.0	0.850	0.0	10.88	-4.69	6.63	0
44DOSP	No44 DO.Serv.P	0.0	0.850	0.0	13.21	-4.95	6.48	0
45DOP	No45 DO.Serv.P	0.0	0.850	0.0	26.15	-5.74	9.65	0
SUBTOTAL		19.0			16.35	-3.05	0.57	18

## CONTENTS : FW=Fresh Water (RHO=1)

20FWT1P	No20 FWT.P	3.9	1.000	10.0	69.20	-6.13	3.07	1
21FWT1S	No21 FWT.S	3.9	1.000	10.0	69.20	6.13	3.07	1
22FWTP	No22 FWT.2P	15.4	1.000	50.0	3.06	-5.15	8.27	12
23DWTS	No23 FWT.2S	9.5	1.000	50.0	3.07	5.96	8.46	4
24APT	No24 Aft Peak	56.0	1.000	100.0	7.25	0.00	2.70	0



# DNV Emergency Response Service

ANNEX C

2009-03-23

17:45

Page 4



DNV.ID26559

CRETE CEMENT

SUBTOTAL		88.7			11.52	-0.26	4.32	18
----------	--	------	--	--	-------	-------	------	----

ID	DES	MASS t	DENS t/m3	FILL %	LCG m	TCG m	VCG m	FRSM tm
----	-----	-----------	--------------	-----------	----------	----------	----------	------------

CONTENTS : HFO=Heavy Fuel Oil (RHO=0.96)

32HFO2P	No32 HFO.St.2	6.5	0.960	10.3	36.78	-2.39	0.05	50
33HFO2S	No33 HFO.Stor.	6.5	0.960	9.6	37.14	2.33	0.05	55
34HFO3P	No34 HFO.Stor.	37.0	0.960	38.2	41.90	-3.72	2.21	54
35HFO3S	No35 HFO.Stor.	37.0	0.960	35.7	41.90	3.72	2.13	55
36FOSETP	No36 FO.Stl.P	0.0	0.960	0.0	16.07	-5.88	6.42	0
37FOS1P	No37 HFO.Serv.	8.6	0.960	100.0	18.80	-4.63	6.33	0
38FOS2P	No38 HFO.Serv.	12.9	0.960	100.0	17.05	-4.63	6.33	0
FOVS	No39 F.O.Over.	0.0	0.960	0.0	17.37	3.31	0.68	0
63FODRP	No63 Fo.Drain.	0.0	0.960	0.0	22.31	-4.58	0.53	0

SUBTOTAL		108.5			36.52	-0.92	2.74	214
----------	--	-------	--	--	-------	-------	------	-----

CONTENTS : LO=Lubricating Oil (RHO=0.9)

50RGLO	No50 RG.LO.P	0.0	0.900	0.0	7.25	-4.14	6.58	0
51DGLOP	No51 DG.LO.P	0.0	0.900	0.0	7.92	-2.99	6.20	0
52LOS	No52 LO.DG.S	0.0	0.900	0.0	7.92	2.99	6.20	0
53TCLOS	No53 TC L.O.S	0.0	0.900	0.0	7.25	4.14	6.58	0
54LOSTRS	No54 ME.LO.S	0.0	0.900	0.0	14.61	5.12	6.43	0
64LODRC	No64 LO.Drain	3.9	0.900	50.0	18.10	0.00	0.35	2
56WOC	No56 Waste.C	4.6	0.900	50.0	13.90	-0.00	0.35	2
57LUB.P		1.5	0.900	0.0	24.75	-5.84	9.56	0
58LUB.P		1.5	0.900	0.0	24.05	-5.84	9.56	0
59LUB.P		1.5	0.900	0.0	23.35	-5.84	9.56	0

SUBTOTAL		12.8			18.62	-1.99	3.49	4
----------	--	------	--	--	-------	-------	------	---

CONTENTS : MIS=MISCELLANEOUS (RHO=1)

60BT	No.60 Bilge T.	12.1	1.000	100.0	10.12	0.00	0.78	0
61SLUP	No61 Sludge.P	7.9	0.900	100.0	20.58	-3.79	0.53	0
62SEWS	No62 Sewage	12.3	1.000	100.0	13.96	2.69	0.79	0

SUBTOTAL		32.3			14.13	0.10	0.72	0
----------	--	------	--	--	-------	------	------	---

CONTENTS : MMA=Machinery Sp. (RHO=1)

ER	Engine Room	0.0	1.000	0.0	15.45	0.22	5.39	0
BTR	Bow.Thr.Rm	0.0	1.000	0.0	81.14	-0.00	3.14	0
SGR	Steer.Gear.Rm	0.0	1.000	0.0	0.61	0.19	9.37	0
TUNNEL	Void	0.0	1.000	0.0	52.08	-0.02	1.98	0
MACHAFT	Aft Machine R.	0.0	1.000	0.0	23.65	0.12	9.29	0
MACH-MID	Midship Machi.	0.0	1.000	0.0	42.60	0.00	9.10	0
MACH-FWD	Forward Deckh.	0.0	1.000	0.0	66.05	0.00	9.11	0

SUBTOTAL		0.0			0.00	0.00	0.00	0
----------	--	-----	--	--	------	------	------	---



# DNV Emergency Response Service

ANNEX C

2009-03-23

17:45

Page 5



DNV.ID26559

CRETE CEMENT

ID	DES	MASS t	DENS t/m3	FILL %	LCG m	TCG m	VCG m	FRSM tm
-----								
CONTENTS : STO=Stores (RHO=1)								
BSN	Bosun Store	0.0	1.000	0.0	86.64	0.00	9.28	0
CONTENTS : MASS= (RHO=0)								
(UNKNOWN_.		118.1	0.000	0.0	35.97	4.29	5.63	0
CONTENTS : VOID=Void (RHO=1.025)								
VSA	Void	0.0	1.025	0.0	13.03	0.00	9.27	0
VS#6	Void	0.0	1.025	0.0	2.78	0.13	7.10	0
CD#15	Void	0.0	1.025	0.0	17.24	-0.06	0.84	0
VS-CH1	Void	0.0	1.025	0.0	73.30	0.00	2.56	0
VS-CH2P	Void	0.0	1.025	0.0	54.28	-4.15	1.47	0
VS-CH2S	Void	0.0	1.025	0.0	54.28	4.15	1.47	0
VS-CH3P	Void	0.0	1.025	0.0	31.34	-3.90	1.54	0
VS-CH3S	Void	0.0	1.025	0.0	31.34	3.90	1.54	0
VS117P	Void	0.0	1.025	0.0	83.12	-1.14	1.47	0
VS117S	Void	0.0	1.025	0.0	83.12	1.14	1.47	0
COFF#57	Coff.above HF.	0.0	1.025	0.0	41.90	0.00	7.39	0
CD-H2S	Void	0.0	1.025	0.0	56.97	7.35	8.01	0
CD-H2P	Void	0.0	1.025	0.0	56.97	-7.35	8.01	0
CD-H3S	Void	0.0	1.025	0.0	32.47	7.49	8.00	0
CD-H3P	Void	0.0	1.025	0.0	32.47	-7.49	8.00	0
PASP	Passage Way P	0.0	1.025	0.0	57.32	-6.63	6.30	0
PASS	Passage Way S	0.0	1.025	0.0	57.32	6.63	6.30	0
CD-H1C	Void	0.0	1.025	0.0	75.97	0.00	8.14	0
-----								
SUBTOTAL		0.0			0.00	0.00	0.00	0
CONTENTS : WB=Water Ballast (RHO=1.025)								
FPT	01 Fore Peak	0.0	1.025	0.0	86.58	0.00	5.75	0
WBT1P	WB02.P	0.0	1.025	0.0	72.06	-3.32	1.08	0
WBT1S	WB03.S	0.0	1.025	0.0	72.06	3.32	1.08	0
WBT2P	WB04.P	0.0	1.025	0.0	59.57	-6.88	2.06	0
WBT2S	WB05.S	0.0	1.025	0.0	59.57	6.88	2.06	0
WBT3P	WB06.P	0.0	1.025	0.0	46.80	-6.92	2.04	0
WBT3S	WB07.S	0.0	1.025	0.0	46.80	6.92	2.04	0
WBT4P	WB08.P	0.0	1.025	0.0	32.13	-6.86	2.06	0
WBT4S	WB09.S	0.0	1.025	0.0	32.13	6.86	2.06	0
WBT5P	WB10.P	2.3	1.025	2.4	74.22	-4.91	2.04	102
WBT5S	WB11.S	2.3	1.025	2.3	74.22	4.91	2.04	108
-----								
SUBTOTAL		4.7			74.22	-0.00	2.04	210
-----								
TOTAL		5393.0			48.60	0.06	5.38	464



## STABILITY SUMMARY

=====

## CRITERIA LIST

Environment: INTACT  
Criteria group: CR\_I Defaults

LOADING CONDITION ER#GROUNDING08#1-TMP, Cond.5 Full.Arr

Heel (deg)	0.8	5.0	10.0	20.0	30.0	40.0	45.0
KN (m)	0.072	0.629	1.310	2.540	3.526	4.338	4.684
dGZ (m)	0.001	0.004	0.006	0.010	0.014	0.019	0.021
GZ (m)	-0.01	0.13	0.32	0.60	0.68	0.68	0.66
e(phi) (mrad)	-0.000	0.004	0.024	0.107	0.220	0.341	0.400

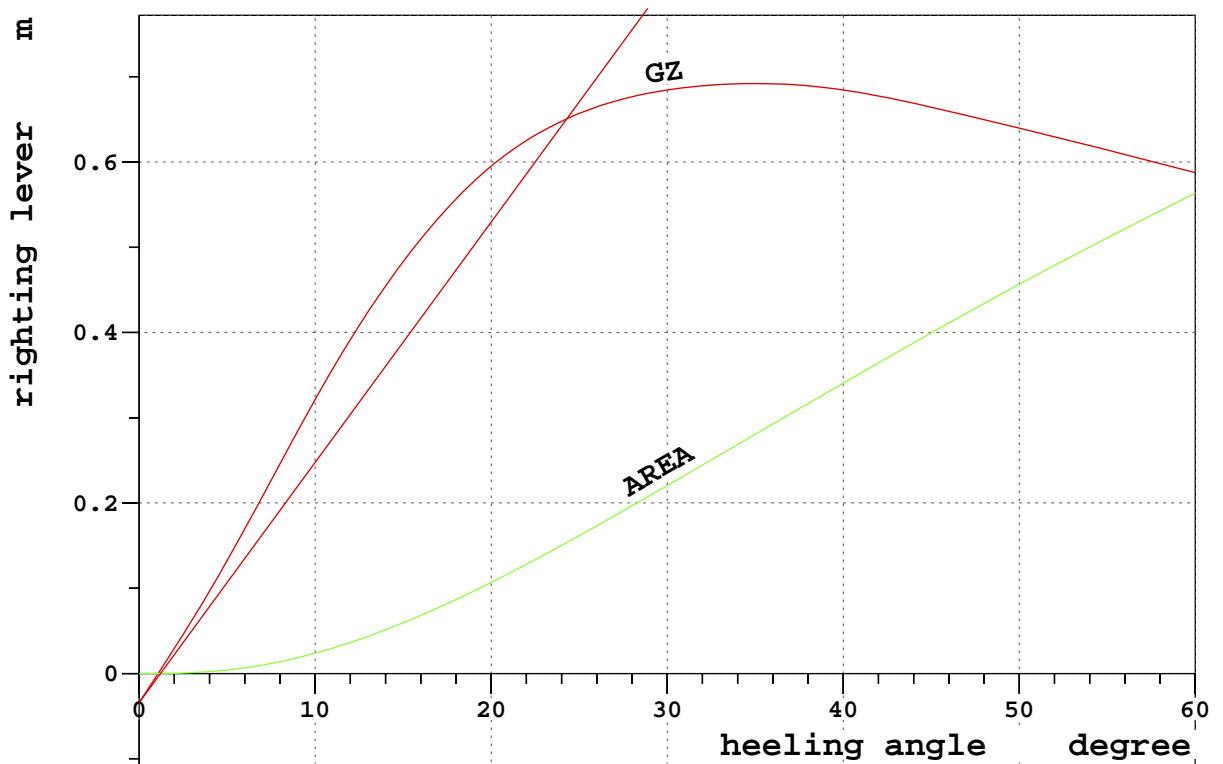



### STRENGTH SUMMARY

=====

LOADING CONDITION ER#GROUNDING08#1-TMP, Cond.5 Full.Arr

		POSITION:	X	FRAME
SHEAR FORCE (MIN)	-181.5 t		67.8 m	96
SHEAR FORCE (MAX)	176.7 t		40.5 m	57
MAX. REL. SHEAR FORCE	29.3 %		67.8 m	96
SAGGING MOMENT	-1.4 tm		91.6 m	132
HOGGING MOMENT	4520.2 tm		42.6 m	60
MAX. REL. SAGGING MOMENT	-			
MAX. REL. HOGGING MOMENT	45.3 %		42.6 m	60

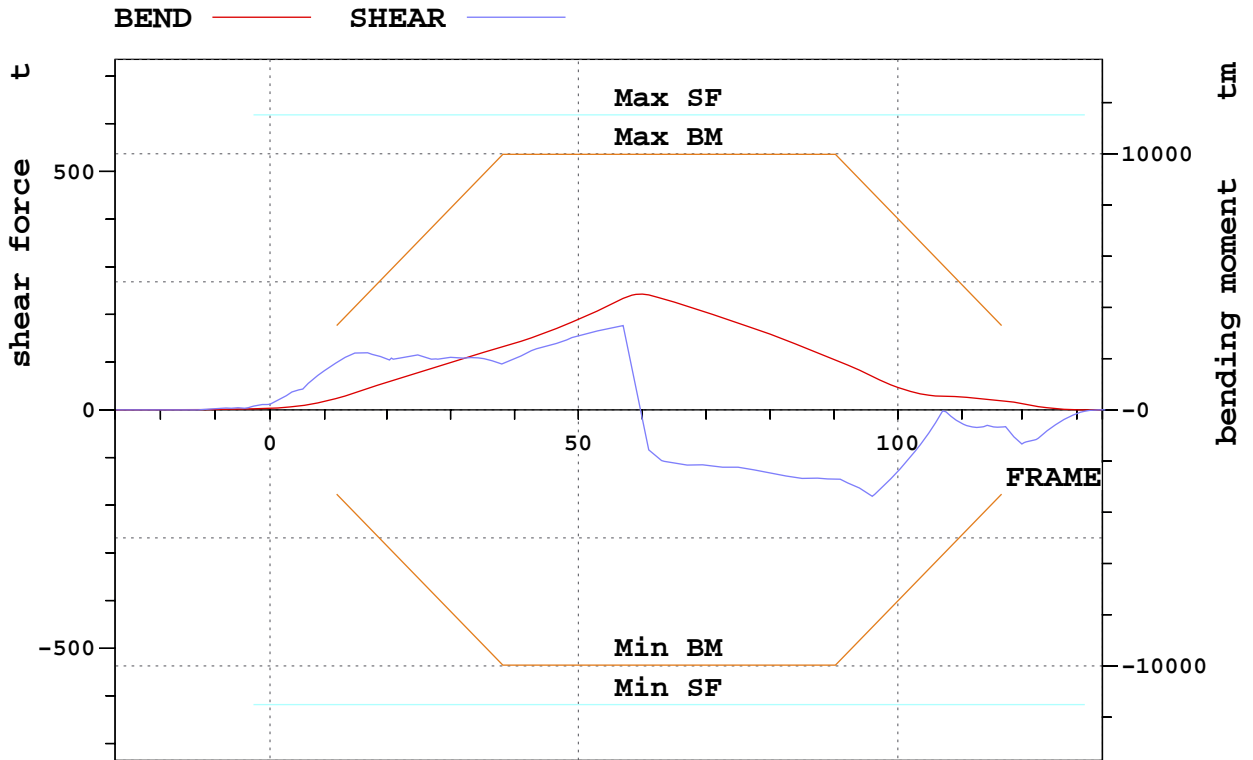



# DNV Emergency Response Service

DNV.ID26559

CRETE CEMENT

## CONDITION SUMMARY: DAMAGED CONDITION

=====

Scenario: GROUNDING08

Condition: Damage case 4

## Description note:

Same as damage case 1 but with max free surface  
Refer to filling of the tanks.

## FLOATING CONDITION (ACTUAL)

Draft FP	7.87 m	KMT	7.747 m	Strength limits SEA	
Draft M	7.32 m	KG	5.656 m	SFmax	53.6 %
Draft AP	6.77 m	FSC	0.057 m	BMmax	68.5 %
		GMact	1.622 m	Outflow	0.0 t
Trim (aft+)	-1.10 m	KGint	5.713 m	Sea Ingr.	400.1 t
Heel (SB+)	0.09 deg			Gro Force	0.0 t

## INTACT DETAILS

## LOADS

Item	Weight (t)	L.C.G. (m)	T.C.G. (m)	V.C.G. (m)	Frs.mom. (tm)
Bulk cargo	5003.3	50.25	-0.00	5.50	0.0
Water Ballast	4.7	74.22	-0.00	2.04	210.2
Fresh Water	88.7	11.52	-0.26	4.32	18.4
Heavy Fuel Oil	108.5	36.52	-0.92	2.74	213.6
Diesel Oil	19.0	16.35	-3.05	0.57	18.0
Lubricating Oil	12.8	18.62	-1.99	3.49	3.5
MISCELLANEOUS	32.3	14.13	0.10	0.72	0.0
Constants	5.5	15.00	1.11	13.55	0.0
	118.1	35.97	4.29	5.63	0.0
Deadweight	5393.0	48.60	0.06	5.38	463.8
Lightweight	2748.6	39.74	-0.11	6.20	
Displacement (1.025 t/m3)	8141.7	45.60	-0.00	5.66	463.8



DNV

# DNV Emergency Response Service

ANNEX C

2009-03-23

18:08

Page 2

DNV.ID26559

CRETE CEMENT

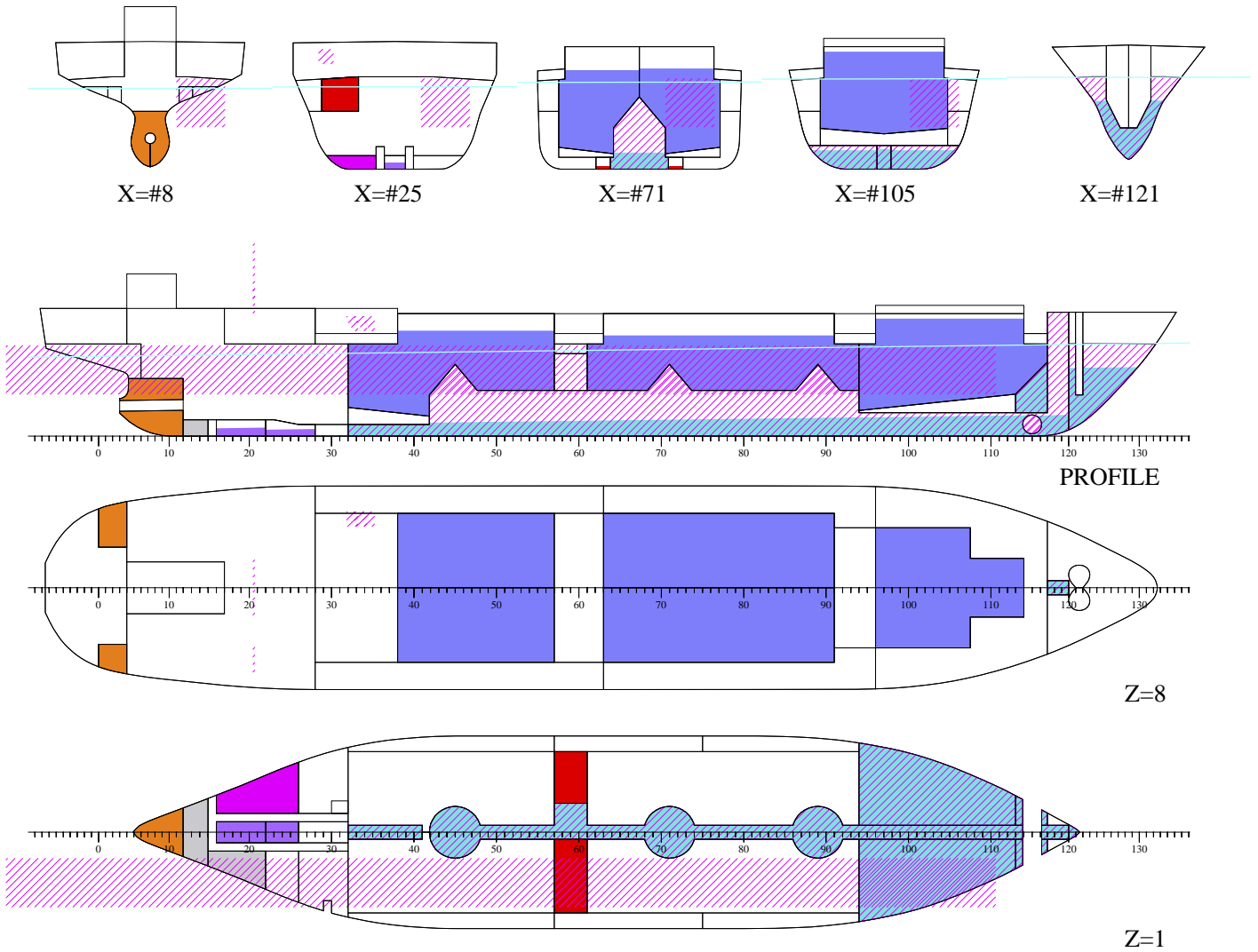

- |                |               |                 |
|----------------|---------------|-----------------|
| Bulk cargo     | Water Ballast | Fresh Water     |
| Heavy Fuel Oil | Diesel Oil    | Lubricating Oil |
| MISCELLANEOUS  | Constants     |                 |





## COMPARTMENT LIST

ID	DES	MASS t	DENS t/m3	FILL %	LCG m	TCG m	VCG m	FRSM tm
----	-----	-----------	--------------	-----------	----------	----------	----------	------------

## CONTENTS : CAB=Bulk cargo (RHO=1.2)

CH1	No1 cargo hold	996.5	1.200	95.0	72.64	0.00	6.38	0
CH2P	No2 C.Hold.P	1113.3	1.200	79.5	54.83	-3.52	5.17	0
CH2S	No2 C.Hold.S	1113.3	1.200	80.9	54.82	3.51	5.23	0
CH3P	No3 C.Hold.P	890.1	1.200	86.2	31.99	-3.44	5.38	0
CH3S	No3 C.Hold.S	890.1	1.200	86.2	31.99	3.44	5.38	0
SUBTOTAL		5003.3			50.25	-0.00	5.50	0

## CONTENTS : CHA=Chain Locker (RHO=1.025)

CLP	Chain Locker	0.0	1.025	0.0	85.10	-0.94	7.34	0
CLS	Chain Locker	0.0	1.025	0.0	85.10	0.94	7.34	0
SUBTOTAL		0.0			0.00	0.00	0.00	0

## CONTENTS : MASS=Constants (RHO=1)

CREW		4.5	1.000	0.0	15.00	0.00	14.00	0
PROV		1.0	1.000	0.0	15.00	6.11	11.50	0
SUBTOTAL		5.5			15.00	1.11	13.55	0

## CONTENTS : DO=Diesel Oil (RHO=0.85)

30DO1P	No30 DO.Stor..	0.0	0.850	0.0	0.00	0.00	0.00	0
31DO1S	No31 DO.Stor..	0.0	0.850	0.0	0.00	0.00	0.00	0
40DOSTP	No40 DO.Stor.P	19.0	0.850	79.2	16.35	-3.05	0.57	18
41DOS	No41 DO.Stor.S	0.0	0.850	0.0	0.00	0.00	0.00	0
42DOSTS	No42 DO.Stor.S	0.0	0.850	0.0	11.68	4.78	6.57	0
43DOSETP	No43 DO.Sett.P	0.0	0.850	0.0	10.88	-4.69	6.63	0
44DOSP	No44 DO.Serv.P	0.0	0.850	0.0	13.21	-4.95	6.48	0
45DOP	No45 DO.Serv.P	0.0	0.850	0.0	26.15	-5.74	9.65	0
SUBTOTAL		19.0			16.35	-3.05	0.57	18

## CONTENTS : FW=Fresh Water (RHO=1)

20FWT1P	No20 FWT.P	3.9	1.000	10.0	69.20	-6.13	3.07	1
21FWT1S	No21 FWT.S	3.9	1.000	10.0	69.20	6.13	3.07	1
22FWTP	No22 FWT.2P	15.4	1.000	50.0	3.06	-5.15	8.27	12
23DWTS	No23 FWT.2S	9.5	1.000	50.0	3.07	5.96	8.46	4
24APT	No24 Aft Peak	56.0	1.000	100.0	7.25	0.00	2.70	0



# DNV Emergency Response Service

ANNEX C

2009-03-23

18:08

Page 4



DNV.ID26559

CRETE CEMENT

SUBTOTAL		88.7			11.52	-0.26	4.32	18
----------	--	------	--	--	-------	-------	------	----

ID	DES	MASS t	DENS t/m3	FILL %	LCG m	TCG m	VCG m	FRSM tm
----	-----	-----------	--------------	-----------	----------	----------	----------	------------

CONTENTS : HFO=Heavy Fuel Oil (RHO=0.96)

32HFO2P	No32 HFO.St.2	6.5	0.960	10.3	36.78	-2.39	0.05	50
33HFO2S	No33 HFO.Stor.	6.5	0.960	9.6	37.14	2.33	0.05	55
34HFO3P	No34 HFO.Stor.	37.0	0.960	38.2	41.90	-3.72	2.21	54
35HFO3S	No35 HFO.Stor.	37.0	0.960	35.7	41.90	3.72	2.13	55
36FOSETP	No36 FO.Stl.P	0.0	0.960	0.0	16.07	-5.88	6.42	0
37FOS1P	No37 HFO.Serv.	8.6	0.960	100.0	18.80	-4.63	6.33	0
38FOS2P	No38 HFO.Serv.	12.9	0.960	100.0	17.05	-4.63	6.33	0
FOVS	No39 F.O.Over.	0.0	0.960	0.0	17.37	3.31	0.68	0
63FODRP	No63 Fo.Drain.	0.0	0.960	0.0	22.31	-4.58	0.53	0

SUBTOTAL		108.5			36.52	-0.92	2.74	214
----------	--	-------	--	--	-------	-------	------	-----

CONTENTS : LO=Lubricating Oil (RHO=0.9)

50RGLO	No50 RG.LO.P	0.0	0.900	0.0	7.25	-4.14	6.58	0
51DGLOP	No51 DG.LO.P	0.0	0.900	0.0	7.92	-2.99	6.20	0
52LOS	No52 LO.DG.S	0.0	0.900	0.0	7.92	2.99	6.20	0
53TCLOS	No53 TC L.O.S	0.0	0.900	0.0	7.25	4.14	6.58	0
54LOSTRS	No54 ME.LO.S	0.0	0.900	0.0	14.61	5.12	6.43	0
64LODRC	No64 LO.Drain	3.9	0.900	50.0	18.10	0.00	0.35	2
56WOC	No56 Waste.C	4.6	0.900	50.0	13.90	-0.00	0.35	2
57LUB.P		1.5	0.900	0.0	24.75	-5.84	9.56	0
58LUB.P		1.5	0.900	0.0	24.05	-5.84	9.56	0
59LUB.P		1.5	0.900	0.0	23.35	-5.84	9.56	0

SUBTOTAL		12.8			18.62	-1.99	3.49	4
----------	--	------	--	--	-------	-------	------	---

CONTENTS : MIS=MISCELLANEOUS (RHO=1)

60BT	No.60 Bilge T.	12.1	1.000	100.0	10.12	0.00	0.78	0
61SLUP	No61 Sludge.P	7.9	0.900	100.0	20.58	-3.79	0.53	0
62SEWS	No62 Sewage	12.3	1.000	100.0	13.96	2.69	0.79	0

SUBTOTAL		32.3			14.13	0.10	0.72	0
----------	--	------	--	--	-------	------	------	---

CONTENTS : MMA=Machinery Sp. (RHO=1)

ER	Engine Room	0.0	1.000	0.0	15.45	0.22	5.39	0
BTR	Bow.Thr.Rm	0.0	1.000	0.0	81.14	-0.00	3.14	0
SGR	Steer.Gear.Rm	0.0	1.000	0.0	0.61	0.19	9.37	0
TUNNEL	Void	0.0	1.000	0.0	52.08	-0.02	1.98	0
MACHAFT	Aft Machine R.	0.0	1.000	0.0	23.65	0.12	9.29	0
MACH-MID	Midship Machi.	0.0	1.000	0.0	42.60	0.00	9.10	0
MACH-FWD	Forward Deckh.	0.0	1.000	0.0	66.05	0.00	9.11	0

SUBTOTAL		0.0			0.00	0.00	0.00	0
----------	--	-----	--	--	------	------	------	---



# DNV Emergency Response Service

ANNEX C

2009-03-23

18:08

Page 5



DNV.ID26559

CRETE CEMENT

ID	DES	MASS t	DENS t/m3	FILL %	LCG m	TCG m	VCG m	FRSM tm
-----								
CONTENTS : STO=Stores (RHO=1)								
BSN	Bosun Store	0.0	1.000	0.0	86.64	0.00	9.28	0
CONTENTS : MASS= (RHO=0)								
(UNKNOWN_.		118.1	0.000	0.0	35.97	4.29	5.63	0
CONTENTS : VOID=Void (RHO=1.025)								
VSA	Void	0.0	1.025	0.0	13.03	0.00	9.27	0
VS#6	Void	0.0	1.025	0.0	2.78	0.13	7.10	0
CD#15	Void	0.0	1.025	0.0	17.24	-0.06	0.84	0
VS-CH1	Void	0.0	1.025	0.0	73.30	0.00	2.56	0
VS-CH2P	Void	0.0	1.025	0.0	54.28	-4.15	1.47	0
VS-CH2S	Void	0.0	1.025	0.0	54.28	4.15	1.47	0
VS-CH3P	Void	0.0	1.025	0.0	31.34	-3.90	1.54	0
VS-CH3S	Void	0.0	1.025	0.0	31.34	3.90	1.54	0
VS117P	Void	0.0	1.025	0.0	83.12	-1.14	1.47	0
VS117S	Void	0.0	1.025	0.0	83.12	1.14	1.47	0
COFF#57	Coff.above HF.	0.0	1.025	0.0	41.90	0.00	7.39	0
CD-H2S	Void	0.0	1.025	0.0	56.97	7.35	8.01	0
CD-H2P	Void	0.0	1.025	0.0	56.97	-7.35	8.01	0
CD-H3S	Void	0.0	1.025	0.0	32.47	7.49	8.00	0
CD-H3P	Void	0.0	1.025	0.0	32.47	-7.49	8.00	0
PASP	Passage Way P	0.0	1.025	0.0	57.32	-6.63	6.30	0
PASS	Passage Way S	0.0	1.025	0.0	57.32	6.63	6.30	0
CD-H1C	Void	0.0	1.025	0.0	75.97	0.00	8.14	0
-----								
SUBTOTAL		0.0			0.00	0.00	0.00	0
CONTENTS : WB=Water Ballast (RHO=1.025)								
FPT	01 Fore Peak	0.0	1.025	0.0	86.58	0.00	5.75	0
WBT1P	WB02.P	0.0	1.025	0.0	72.06	-3.32	1.08	0
WBT1S	WB03.S	0.0	1.025	0.0	72.06	3.32	1.08	0
WBT2P	WB04.P	0.0	1.025	0.0	59.57	-6.88	2.06	0
WBT2S	WB05.S	0.0	1.025	0.0	59.57	6.88	2.06	0
WBT3P	WB06.P	0.0	1.025	0.0	46.80	-6.92	2.04	0
WBT3S	WB07.S	0.0	1.025	0.0	46.80	6.92	2.04	0
WBT4P	WB08.P	0.0	1.025	0.0	32.13	-6.86	2.06	0
WBT4S	WB09.S	0.0	1.025	0.0	32.13	6.86	2.06	0
WBT5P	WB10.P	2.3	1.025	2.4	74.22	-4.91	2.04	102
WBT5S	WB11.S	2.3	1.025	2.3	74.22	4.91	2.04	108
-----								
SUBTOTAL		4.7			74.22	-0.00	2.04	210
-----								
TOTAL		5393.0			48.60	0.06	5.38	464



### STABILITY SUMMARY

=====

### CRITERIA LIST

Environment: INTACT  
Criteria group: CR\_I Defaults

### LOADING CONDITION ER#GROUNDING08#1-TMP, Cond.5 Full.Arr

Heel (deg)	0.8	5.0	10.0	20.0	30.0	40.0	45.0
KN (m)	0.099	0.632	1.248	2.357	3.419	4.310	4.679
dGZ (m)	0.001	0.004	0.006	0.010	0.014	0.019	0.021
GZ (m)	0.02	0.14	0.26	0.41	0.58	0.66	0.66
e(phi) (mrad)	0.000	0.006	0.023	0.082	0.169	0.278	0.336

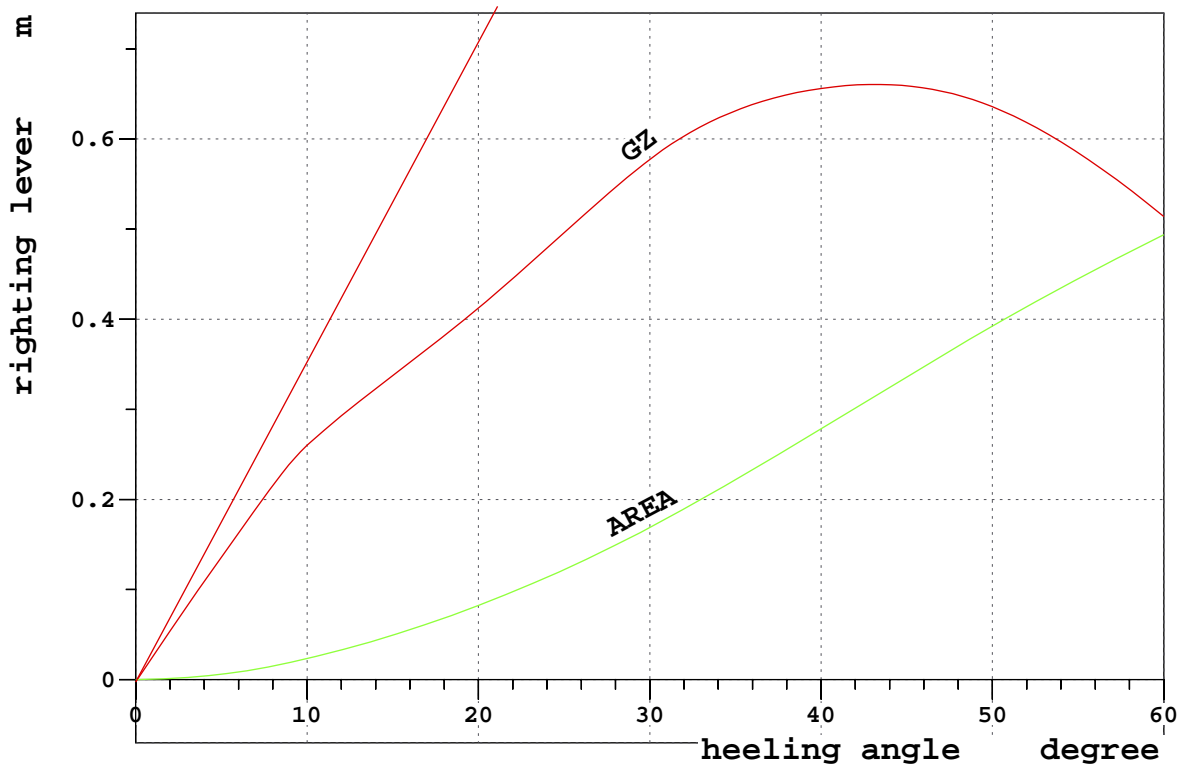



### STRENGTH SUMMARY

=====

LOADING CONDITION ER#GROUNDING08#1-TMP, Cond.5 Full.Arr

		POSITION:	X	FRAME
SHEAR FORCE (MIN)	-180.3 t		23.0 m	32
SHEAR FORCE (MAX)	331.7 t		10.1 m	14
MAX. REL. SHEAR FORCE	53.6 %		10.1 m	14
SAGGING MOMENT	-0.2 tm		92.6 m	134
HOGGING MOMENT	4572.5 tm		20.5 m	29
MAX. REL. SAGGING MOMENT	-			
MAX. REL. HOGGING MOMENT	68.5 %		15.1 m	21

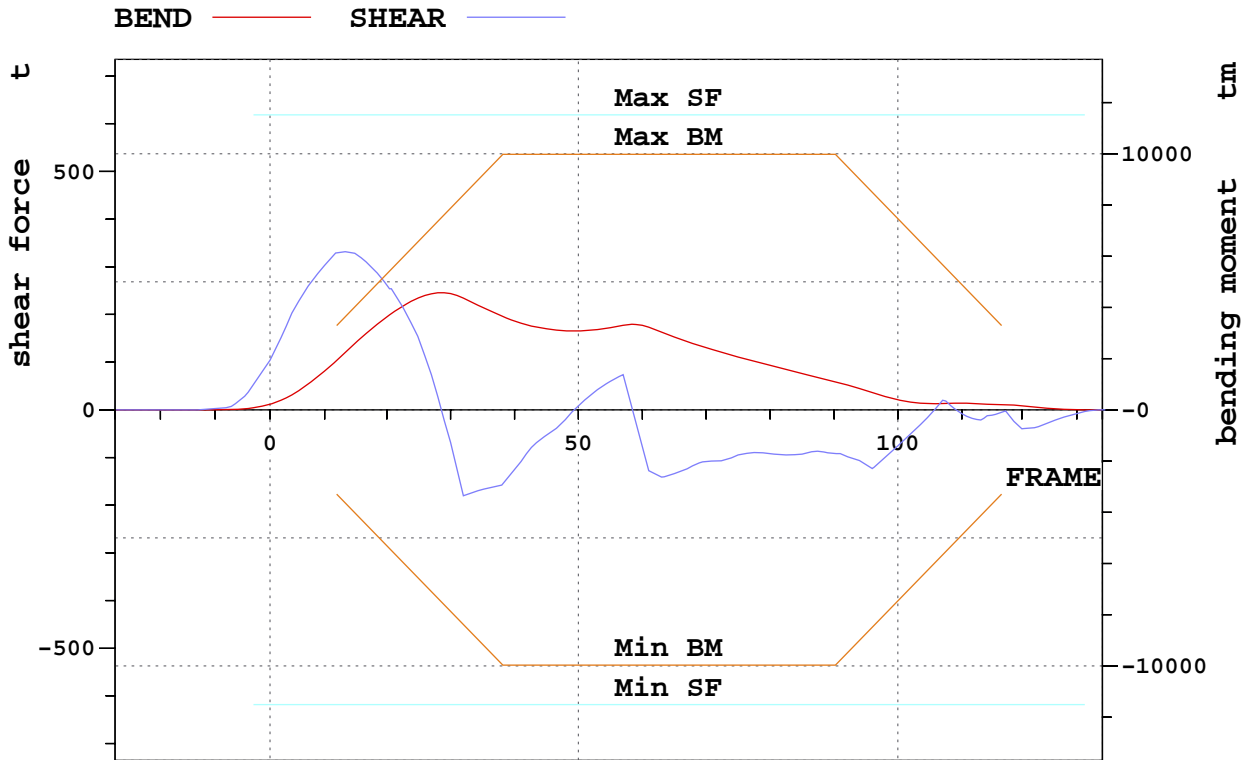



## CONDITION SUMMARY: DAMAGED CONDITION

=====

Scenario: GROUNDING08

Condition: Damage case 5

## Description note:

Same as damage case 2, but with max free surface effect

Refer to filling of tanks.

## FLOATING CONDITION (ACTUAL)

Draft FP	7.21 m	KMT	7.328 m	Strength limits SEA	
Draft M	7.70 m	KG	5.656 m	SFmax	28.5 %
Draft AP	8.19 m	FSC	0.057 m	BMmax	40.6 %
		GMact	1.072 m	Outflow	0.0 t
Trim (aft+)	0.98 m	KGint	5.713 m	Sea Ingr.	1016.7 t
Heel (SB+)	0.00 deg			Gro Force	0.0 t

## INTACT DETAILS

## LOADS

Item	Weight (t)	L.C.G. (m)	T.C.G. (m)	V.C.G. (m)	Frs.mom. (tm)
Bulk cargo	5003.3	50.25	-0.00	5.50	0.0
Water Ballast	4.7	74.22	-0.00	2.04	210.2
Fresh Water	88.7	11.52	-0.26	4.32	18.4
Heavy Fuel Oil	108.5	36.52	-0.92	2.74	213.6
Diesel Oil	19.0	16.35	-3.05	0.57	18.0
Lubricating Oil	12.8	18.62	-1.99	3.49	3.5
MISCELLANEOUS	32.3	14.13	0.10	0.72	0.0
Constants	5.5	15.00	1.11	13.55	0.0
	118.1	35.97	4.29	5.63	0.0
Deadweight	5393.0	48.60	0.06	5.38	463.8
Lightweight	2748.6	39.74	-0.11	6.20	
Displacement (1.025 t/m3)	8141.7	45.60	-0.00	5.66	463.8

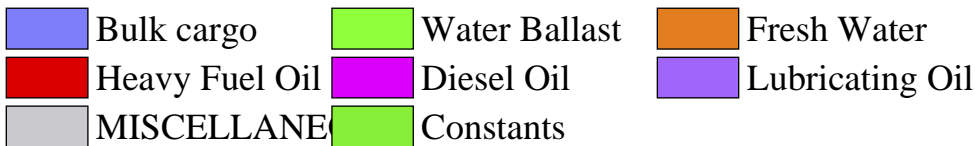
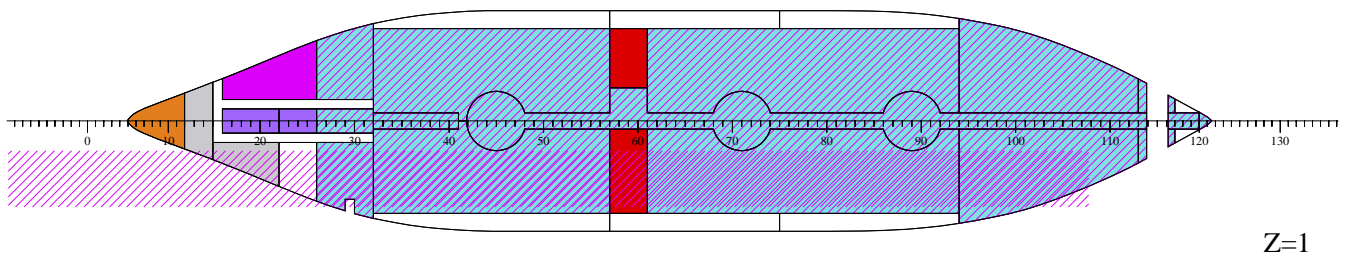
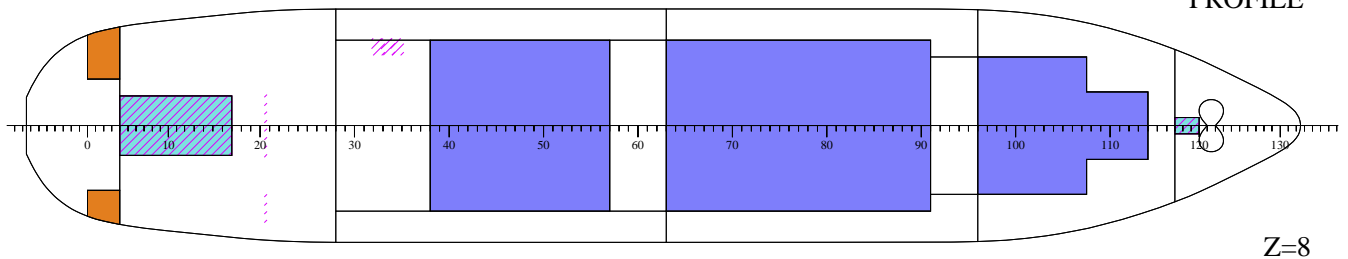
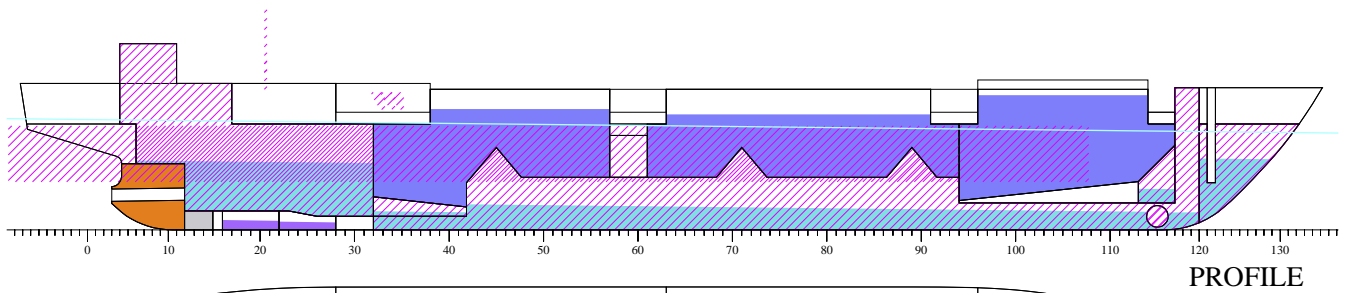
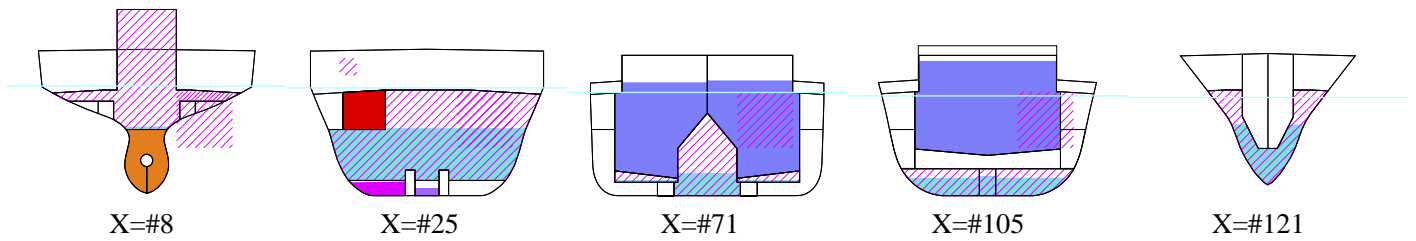



## COMPARTMENT LIST

ID	DES	MASS t	DENS t/m3	FILL %	LCG m	TCG m	VCG m	FRSM tm
CONTENTS : CAB=Bulk cargo (RHO=1.2)								
CH1	No1 cargo hold	996.5	1.200	95.0	72.64	0.00	6.38	0
CH2P	No2 C.Hold.P	1113.3	1.200	79.5	54.83	-3.52	5.17	0
CH2S	No2 C.Hold.S	1113.3	1.200	80.9	54.82	3.51	5.23	0
CH3P	No3 C.Hold.P	890.1	1.200	86.2	31.99	-3.44	5.38	0
CH3S	No3 C.Hold.S	890.1	1.200	86.2	31.99	3.44	5.38	0
SUBTOTAL		5003.3			50.25	-0.00	5.50	0

## CONTENTS : CHA=Chain Locker (RHO=1.025)

CLP	Chain Locker	0.0	1.025	0.0	85.10	-0.94	7.34	0
CLS	Chain Locker	0.0	1.025	0.0	85.10	0.94	7.34	0
SUBTOTAL		0.0			0.00	0.00	0.00	0

## CONTENTS : MASS=Constants (RHO=1)

CREW		4.5	1.000	0.0	15.00	0.00	14.00	0
PROV		1.0	1.000	0.0	15.00	6.11	11.50	0
SUBTOTAL		5.5			15.00	1.11	13.55	0

## CONTENTS : DO=Diesel Oil (RHO=0.85)

30DO1P	No30 DO.Stor..	0.0	0.850	0.0	0.00	0.00	0.00	0
31DO1S	No31 DO.Stor..	0.0	0.850	0.0	0.00	0.00	0.00	0
40DOSTP	No40 DO.Stor.P	19.0	0.850	79.2	16.35	-3.05	0.57	18
41DOS	No41 DO.Stor.S	0.0	0.850	0.0	0.00	0.00	0.00	0
42DOSTS	No42 DO.Stor.S	0.0	0.850	0.0	11.68	4.78	6.57	0
43DOSETP	No43 DO.Sett.P	0.0	0.850	0.0	10.88	-4.69	6.63	0
44DOSP	No44 DO.Serv.P	0.0	0.850	0.0	13.21	-4.95	6.48	0
45DOP	No45 DO.Serv.P	0.0	0.850	0.0	26.15	-5.74	9.65	0
SUBTOTAL		19.0			16.35	-3.05	0.57	18

## CONTENTS : FW=Fresh Water (RHO=1)

20FWT1P	No20 FWT.P	3.9	1.000	10.0	69.20	-6.13	3.07	1
21FWT1S	No21 FWT.S	3.9	1.000	10.0	69.20	6.13	3.07	1
22FWTP	No22 FWT.2P	15.4	1.000	50.0	3.06	-5.15	8.27	12
23DWTS	No23 FWT.2S	9.5	1.000	50.0	3.07	5.96	8.46	4
24APT	No24 Aft Peak	56.0	1.000	100.0	7.25	0.00	2.70	0





# DNV Emergency Response Service

ANNEX C

2009-03-23

18:14

Page 4



DNV.ID26559

CRETE CEMENT

SUBTOTAL		88.7		11.52	-0.26	4.32	18
----------	--	------	--	-------	-------	------	----

ID	DES	MASS t	DENS t/m3	FILL %	LCG m	TCG m	VCG m	FRSM tm
----	-----	-----------	--------------	-----------	----------	----------	----------	------------

CONTENTS : HFO=Heavy Fuel Oil (RHO=0.96)

32HFO2P	No32 HFO.St.2	6.5	0.960	10.3	36.78	-2.39	0.05	50
33HFO2S	No33 HFO.Stor.	6.5	0.960	9.6	37.14	2.33	0.05	55
34HFO3P	No34 HFO.Stor.	37.0	0.960	38.2	41.90	-3.72	2.21	54
35HFO3S	No35 HFO.Stor.	37.0	0.960	35.7	41.90	3.72	2.13	55
36FOSETP	No36 FO.Stl.P	0.0	0.960	0.0	16.07	-5.88	6.42	0
37FOS1P	No37 HFO.Serv.	8.6	0.960	100.0	18.80	-4.63	6.33	0
38FOS2P	No38 HFO.Serv.	12.9	0.960	100.0	17.05	-4.63	6.33	0
FOVS	No39 F.O.Over.	0.0	0.960	0.0	17.37	3.31	0.68	0
63FODRP	No63 Fo.Drain.	0.0	0.960	0.0	22.31	-4.58	0.53	0

SUBTOTAL		108.5		36.52	-0.92	2.74	214
----------	--	-------	--	-------	-------	------	-----

CONTENTS : LO=Lubricating Oil (RHO=0.9)

50RGLO	No50 RG.LO.P	0.0	0.900	0.0	7.25	-4.14	6.58	0
51DGLOP	No51 DG.LO.P	0.0	0.900	0.0	7.92	-2.99	6.20	0
52LOS	No52 LO.DG.S	0.0	0.900	0.0	7.92	2.99	6.20	0
53TCLOS	No53 TC L.O.S	0.0	0.900	0.0	7.25	4.14	6.58	0
54LOSTRS	No54 ME.LO.S	0.0	0.900	0.0	14.61	5.12	6.43	0
64LODRC	No64 LO.Drain	3.9	0.900	50.0	18.10	0.00	0.35	2
56WOC	No56 Waste.C	4.6	0.900	50.0	13.90	-0.00	0.35	2
57LUB.P		1.5	0.900	0.0	24.75	-5.84	9.56	0
58LUB.P		1.5	0.900	0.0	24.05	-5.84	9.56	0
59LUB.P		1.5	0.900	0.0	23.35	-5.84	9.56	0

SUBTOTAL		12.8		18.62	-1.99	3.49	4
----------	--	------	--	-------	-------	------	---

CONTENTS : MIS=MISCELLANEOUS (RHO=1)

60BT	No.60 Bilge T.	12.1	1.000	100.0	10.12	0.00	0.78	0
61SLUP	No61 Sludge.P	7.9	0.900	100.0	20.58	-3.79	0.53	0
62SEWS	No62 Sewage	12.3	1.000	100.0	13.96	2.69	0.79	0

SUBTOTAL		32.3		14.13	0.10	0.72	0
----------	--	------	--	-------	------	------	---

CONTENTS : MMA=Machinery Sp. (RHO=1)

ER	Engine Room	0.0	1.000	0.0	15.45	0.22	5.39	0
BTR	Bow.Thr.Rm	0.0	1.000	0.0	81.14	-0.00	3.14	0
SGR	Steer.Gear.Rm	0.0	1.000	0.0	0.61	0.19	9.37	0
TUNNEL	Void	0.0	1.000	0.0	52.08	-0.02	1.98	0
MACHAFT	Aft Machine R.	0.0	1.000	0.0	23.65	0.12	9.29	0
MACH-MID	Midship Machi.	0.0	1.000	0.0	42.60	0.00	9.10	0
MACH-FWD	Forward Deckh.	0.0	1.000	0.0	66.05	0.00	9.11	0

SUBTOTAL		0.0		0.00	0.00	0.00	0
----------	--	-----	--	------	------	------	---



# DNV Emergency Response Service



DNV.ID26559

CRETE CEMENT

ID	DES	MASS t	DENS t/m3	FILL %	LCG m	TCG m	VCG m	FRSM tm
-----								
CONTENTS : STO=Stores (RHO=1)								
BSN	Bosun Store	0.0	1.000	0.0	86.64	0.00	9.28	0
CONTENTS : MASS= (RHO=0)								
(UNKNOWN_.		118.1	0.000	0.0	35.97	4.29	5.63	0
CONTENTS : VOID=Void (RHO=1.025)								
VSA	Void	0.0	1.025	0.0	13.03	0.00	9.27	0
VS#6	Void	0.0	1.025	0.0	2.78	0.13	7.10	0
CD#15	Void	0.0	1.025	0.0	17.24	-0.06	0.84	0
VS-CH1	Void	0.0	1.025	0.0	73.30	0.00	2.56	0
VS-CH2P	Void	0.0	1.025	0.0	54.28	-4.15	1.47	0
VS-CH2S	Void	0.0	1.025	0.0	54.28	4.15	1.47	0
VS-CH3P	Void	0.0	1.025	0.0	31.34	-3.90	1.54	0
VS-CH3S	Void	0.0	1.025	0.0	31.34	3.90	1.54	0
VS117P	Void	0.0	1.025	0.0	83.12	-1.14	1.47	0
VS117S	Void	0.0	1.025	0.0	83.12	1.14	1.47	0
COFF#57	Coff.above HF.	0.0	1.025	0.0	41.90	0.00	7.39	0
CD-H2S	Void	0.0	1.025	0.0	56.97	7.35	8.01	0
CD-H2P	Void	0.0	1.025	0.0	56.97	-7.35	8.01	0
CD-H3S	Void	0.0	1.025	0.0	32.47	7.49	8.00	0
CD-H3P	Void	0.0	1.025	0.0	32.47	-7.49	8.00	0
PASP	Passage Way P	0.0	1.025	0.0	57.32	-6.63	6.30	0
PASS	Passage Way S	0.0	1.025	0.0	57.32	6.63	6.30	0
CD-H1C	Void	0.0	1.025	0.0	75.97	0.00	8.14	0
-----								
SUBTOTAL		0.0			0.00	0.00	0.00	0
CONTENTS : WB=Water Ballast (RHO=1.025)								
FPT	01 Fore Peak	0.0	1.025	0.0	86.58	0.00	5.75	0
WBT1P	WB02.P	0.0	1.025	0.0	72.06	-3.32	1.08	0
WBT1S	WB03.S	0.0	1.025	0.0	72.06	3.32	1.08	0
WBT2P	WB04.P	0.0	1.025	0.0	59.57	-6.88	2.06	0
WBT2S	WB05.S	0.0	1.025	0.0	59.57	6.88	2.06	0
WBT3P	WB06.P	0.0	1.025	0.0	46.80	-6.92	2.04	0
WBT3S	WB07.S	0.0	1.025	0.0	46.80	6.92	2.04	0
WBT4P	WB08.P	0.0	1.025	0.0	32.13	-6.86	2.06	0
WBT4S	WB09.S	0.0	1.025	0.0	32.13	6.86	2.06	0
WBT5P	WB10.P	2.3	1.025	2.4	74.22	-4.91	2.04	102
WBT5S	WB11.S	2.3	1.025	2.3	74.22	4.91	2.04	108
-----								
SUBTOTAL		4.7			74.22	-0.00	2.04	210
-----								
TOTAL		5393.0			48.60	0.06	5.38	464



STABILITY SUMMARY

=====

CRITERIA LIST

Environment: INTACT  
Criteria group: CR\_I Defaults

LOADING CONDITION ER#GROUNDING08#1-TMP, Cond.5 Full.Arr

Heel (deg)	0.8	5.0	10.0	20.0	30.0	40.0	45.0
KN (m)	0.094	0.591	1.155	2.270	3.272	4.117	4.482
dGZ (m)	0.001	0.004	0.006	0.010	0.014	0.019	0.021
GZ (m)	0.02	0.09	0.17	0.33	0.43	0.46	0.46
e(phi) (mrad)	0.000	0.004	0.016	0.059	0.126	0.205	0.245

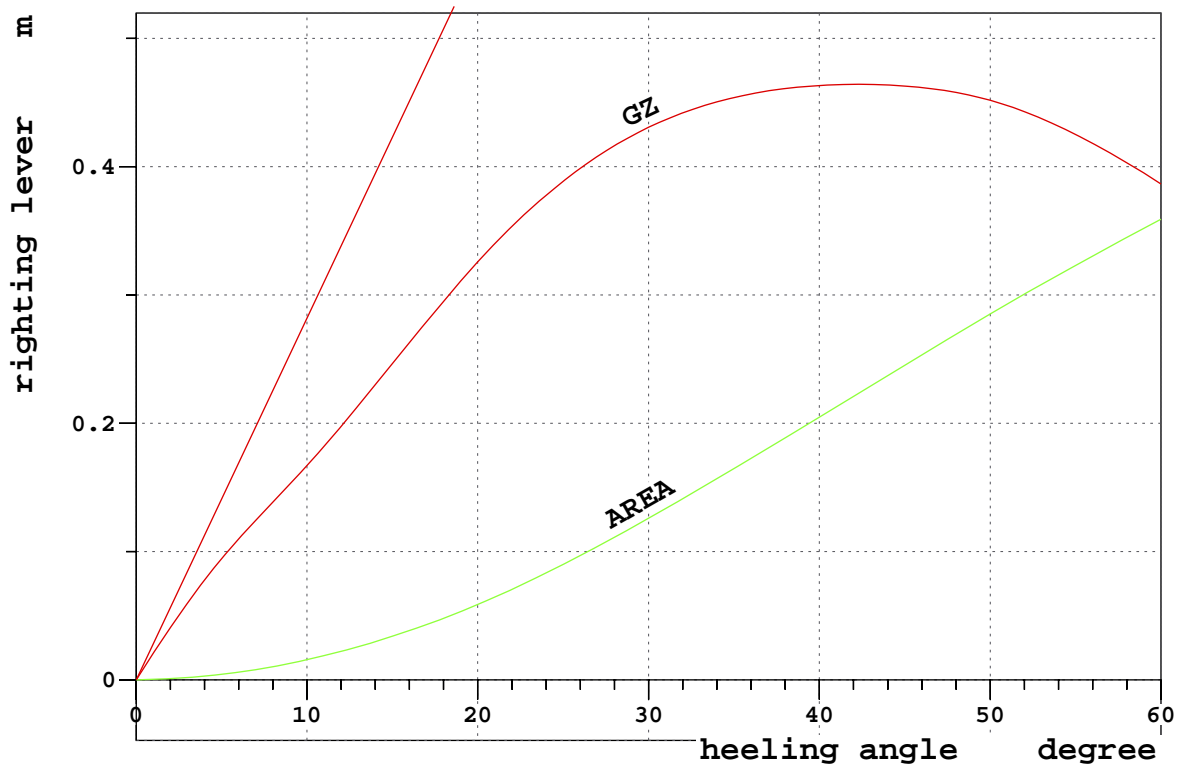



### STRENGTH SUMMARY

=====

LOADING CONDITION ER#GROUNDING08#1-TMP, Cond.5 Full.Arr

		POSITION:	X	FRAME
SHEAR FORCE (MIN)	-144.3 t		67.8 m	96
SHEAR FORCE (MAX)	176.5 t		11.1 m	15
MAX. REL. SHEAR FORCE	28.5 %		11.1 m	15
SAGGING MOMENT	-5.0 tm		91.6 m	132
HOGGING MOMENT	3903.5 tm		41.9 m	59
MAX. REL. SAGGING MOMENT	-			
MAX. REL. HOGGING MOMENT	40.4 %		17.0 m	24

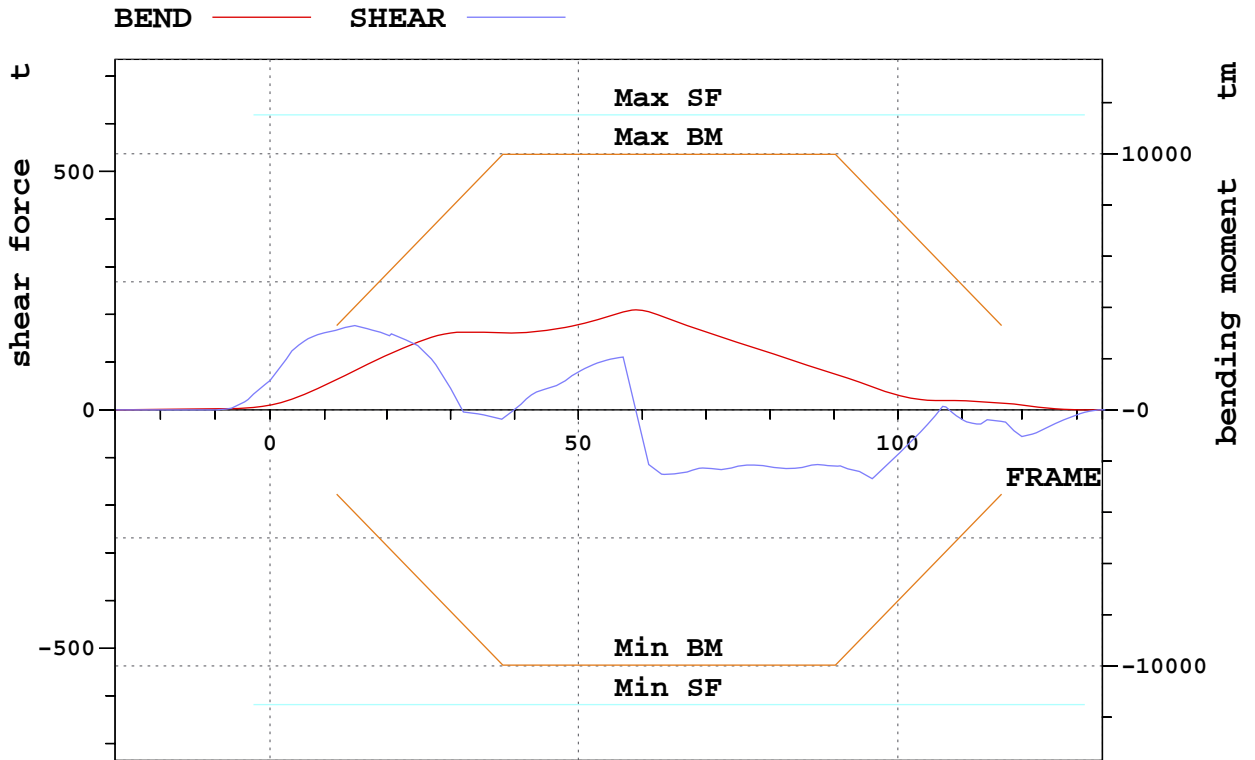



## CONDITION SUMMARY: DAMAGED CONDITION

=====

Scenario: GROUNDING08

Condition: Damage case 6

## Description note:

Same as damage case 3, but with max free surface effect

Refer to tank filling.

## FLOATING CONDITION (ACTUAL)







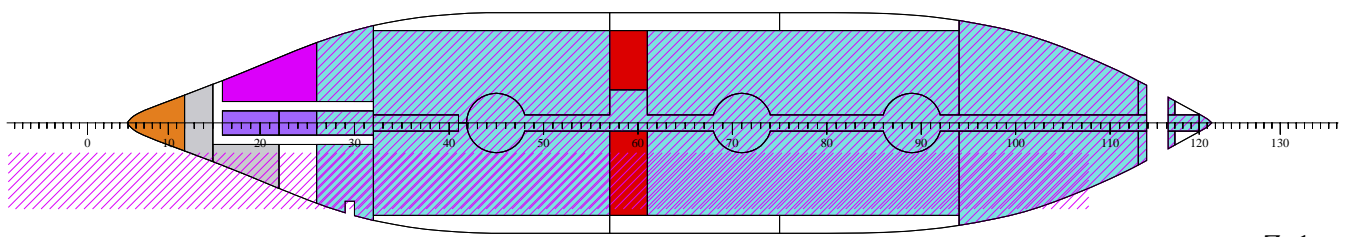
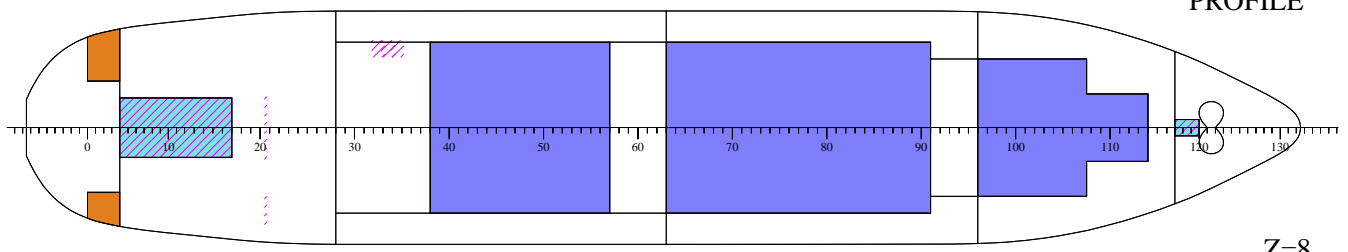
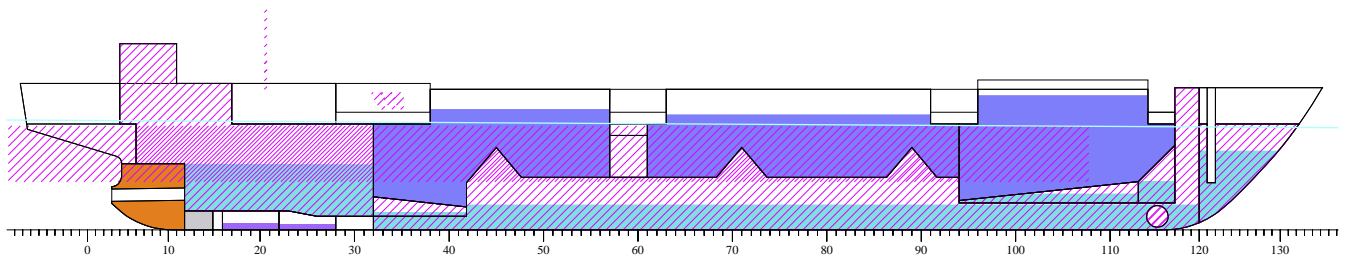
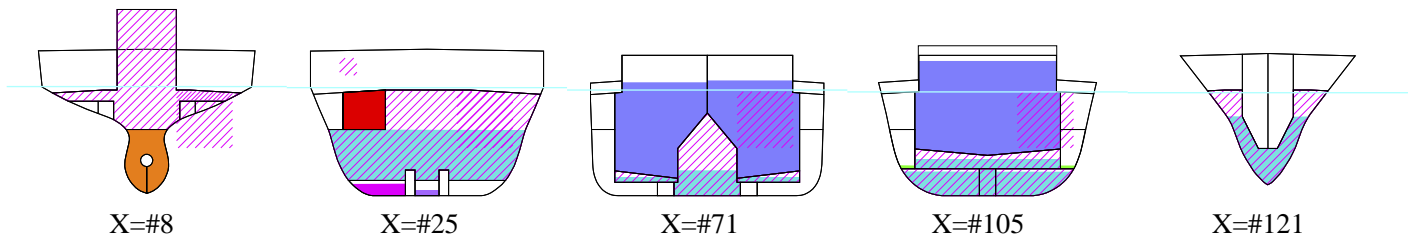

Draft FP	7.59 m	KMT	7.328 m	Strength limits SEA	
Draft M	7.86 m	KG	5.656 m	SFmax	30.1 %
Draft AP	8.12 m	FSC	0.057 m	BMmax	42.1 %
		GMact	1.091 m	Outflow	0.0 t
Trim (aft+)	0.52 m	KGint	5.713 m	Sea Ingr.	1219.4 t
Heel (SB+)	0.00 deg			Gro Force	0.0 t

## INTACT DETAILS

## LOADS

Item	Weight (t)	L.C.G. (m)	T.C.G. (m)	V.C.G. (m)	Frs.mom. (tm)
Bulk cargo	5003.3	50.25	-0.00	5.50	0.0
Water Ballast	4.7	74.22	-0.00	2.04	210.2
Fresh Water	88.7	11.52	-0.26	4.32	18.4
Heavy Fuel Oil	108.5	36.52	-0.92	2.74	213.6
Diesel Oil	19.0	16.35	-3.05	0.57	18.0
Lubricating Oil	12.8	18.62	-1.99	3.49	3.5
MISCELLANEOUS	32.3	14.13	0.10	0.72	0.0
Constants	5.5	15.00	1.11	13.55	0.0
	118.1	35.97	4.29	5.63	0.0
Deadweight	5393.0	48.60	0.06	5.38	463.8
Lightweight	2748.6	39.74	-0.11	6.20	
Displacement (1.025 t/m3)	8141.7	45.60	-0.00	5.66	463.8



- |  |   |   |
|--|---|---|
|  Bulk cargo     |  Water Ballast |  Fresh Water     |
|  Heavy Fuel Oil |  Diesel Oil    |  Lubricating Oil |
|  MISCELLANE     |  Constants     |   |



## COMPARTMENT LIST

ID	DES	MASS t	DENS t/m3	FILL %	LCG m	TCG m	VCG m	FRSM tm
CONTENTS : CAB=Bulk cargo (RHO=1.2)								
CH1	No1 cargo hold	996.5	1.200	95.0	72.64	0.00	6.38	0
CH2P	No2 C.Hold.P	1113.3	1.200	79.5	54.83	-3.52	5.17	0
CH2S	No2 C.Hold.S	1113.3	1.200	80.9	54.82	3.51	5.23	0
CH3P	No3 C.Hold.P	890.1	1.200	86.2	31.99	-3.44	5.38	0
CH3S	No3 C.Hold.S	890.1	1.200	86.2	31.99	3.44	5.38	0
SUBTOTAL		5003.3			50.25	-0.00	5.50	0

## CONTENTS : CHA=Chain Locker (RHO=1.025)

CLP	Chain Locker	0.0	1.025	0.0	85.10	-0.94	7.34	0
CLS	Chain Locker	0.0	1.025	0.0	85.10	0.94	7.34	0
SUBTOTAL		0.0			0.00	0.00	0.00	0

## CONTENTS : MASS=Constants (RHO=1)

CREW		4.5	1.000	0.0	15.00	0.00	14.00	0
PROV		1.0	1.000	0.0	15.00	6.11	11.50	0
SUBTOTAL		5.5			15.00	1.11	13.55	0

## CONTENTS : DO=Diesel Oil (RHO=0.85)

30DO1P	No30 DO.Stor..	0.0	0.850	0.0	0.00	0.00	0.00	0
31DO1S	No31 DO.Stor..	0.0	0.850	0.0	0.00	0.00	0.00	0
40DOSTP	No40 DO.Stor.P	19.0	0.850	79.2	16.35	-3.05	0.57	18
41DOS	No41 DO.Stor.S	0.0	0.850	0.0	0.00	0.00	0.00	0
42DOSTS	No42 DO.Stor.S	0.0	0.850	0.0	11.68	4.78	6.57	0
43DOSETP	No43 DO.Sett.P	0.0	0.850	0.0	10.88	-4.69	6.63	0
44DOSP	No44 DO.Serv.P	0.0	0.850	0.0	13.21	-4.95	6.48	0
45DOP	No45 DO.Serv.P	0.0	0.850	0.0	26.15	-5.74	9.65	0
SUBTOTAL		19.0			16.35	-3.05	0.57	18

## CONTENTS : FW=Fresh Water (RHO=1)

20FWT1P	No20 FWT.P	3.9	1.000	10.0	69.20	-6.13	3.07	1
21FWT1S	No21 FWT.S	3.9	1.000	10.0	69.20	6.13	3.07	1
22FWTP	No22 FWT.2P	15.4	1.000	50.0	3.06	-5.15	8.27	12
23DWTS	No23 FWT.2S	9.5	1.000	50.0	3.07	5.96	8.46	4
24APT	No24 Aft Peak	56.0	1.000	100.0	7.25	0.00	2.70	0



# DNV Emergency Response Service

ANNEX C

2009-03-23

18:19

Page 4



DNV.ID26559

CRETE CEMENT

SUBTOTAL		88.7		11.52	-0.26	4.32	18
----------	--	------	--	-------	-------	------	----

ID	DES	MASS t	DENS t/m3	FILL %	LCG m	TCG m	VCG m	FRSM tm
----	-----	-----------	--------------	-----------	----------	----------	----------	------------

CONTENTS : HFO=Heavy Fuel Oil (RHO=0.96)

32HFO2P	No32 HFO.St.2	6.5	0.960	10.3	36.78	-2.39	0.05	50
33HFO2S	No33 HFO.Stor.	6.5	0.960	9.6	37.14	2.33	0.05	55
34HFO3P	No34 HFO.Stor.	37.0	0.960	38.2	41.90	-3.72	2.21	54
35HFO3S	No35 HFO.Stor.	37.0	0.960	35.7	41.90	3.72	2.13	55
36FOSETP	No36 FO.Stl.P	0.0	0.960	0.0	16.07	-5.88	6.42	0
37FOS1P	No37 HFO.Serv.	8.6	0.960	100.0	18.80	-4.63	6.33	0
38FOS2P	No38 HFO.Serv.	12.9	0.960	100.0	17.05	-4.63	6.33	0
FOVS	No39 F.O.Over.	0.0	0.960	0.0	17.37	3.31	0.68	0
63FODRP	No63 Fo.Drain.	0.0	0.960	0.0	22.31	-4.58	0.53	0

SUBTOTAL		108.5		36.52	-0.92	2.74	214
----------	--	-------	--	-------	-------	------	-----

CONTENTS : LO=Lubricating Oil (RHO=0.9)

50RGLO	No50 RG.LO.P	0.0	0.900	0.0	7.25	-4.14	6.58	0
51DGLOP	No51 DG.LO.P	0.0	0.900	0.0	7.92	-2.99	6.20	0
52LOS	No52 LO.DG.S	0.0	0.900	0.0	7.92	2.99	6.20	0
53TCLOS	No53 TC L.O.S	0.0	0.900	0.0	7.25	4.14	6.58	0
54LOSTRS	No54 ME.LO.S	0.0	0.900	0.0	14.61	5.12	6.43	0
64LODRC	No64 LO.Drain	3.9	0.900	50.0	18.10	0.00	0.35	2
56WOC	No56 Waste.C	4.6	0.900	50.0	13.90	-0.00	0.35	2
57LUB.P		1.5	0.900	0.0	24.75	-5.84	9.56	0
58LUB.P		1.5	0.900	0.0	24.05	-5.84	9.56	0
59LUB.P		1.5	0.900	0.0	23.35	-5.84	9.56	0

SUBTOTAL		12.8		18.62	-1.99	3.49	4
----------	--	------	--	-------	-------	------	---

CONTENTS : MIS=MISCELLANEOUS (RHO=1)

60BT	No.60 Bilge T.	12.1	1.000	100.0	10.12	0.00	0.78	0
61SLUP	No61 Sludge.P	7.9	0.900	100.0	20.58	-3.79	0.53	0
62SEWS	No62 Sewage	12.3	1.000	100.0	13.96	2.69	0.79	0

SUBTOTAL		32.3		14.13	0.10	0.72	0
----------	--	------	--	-------	------	------	---

CONTENTS : MMA=Machinery Sp. (RHO=1)

ER	Engine Room	0.0	1.000	0.0	15.45	0.22	5.39	0
BTR	Bow.Thr.Rm	0.0	1.000	0.0	81.14	-0.00	3.14	0
SGR	Steer.Gear.Rm	0.0	1.000	0.0	0.61	0.19	9.37	0
TUNNEL	Void	0.0	1.000	0.0	52.08	-0.02	1.98	0
MACHAFT	Aft Machine R.	0.0	1.000	0.0	23.65	0.12	9.29	0
MACH-MID	Midship Machi.	0.0	1.000	0.0	42.60	0.00	9.10	0
MACH-FWD	Forward Deckh.	0.0	1.000	0.0	66.05	0.00	9.11	0

SUBTOTAL		0.0		0.00	0.00	0.00	0
----------	--	-----	--	------	------	------	---





# DNV Emergency Response Service

ANNEX C

2009-03-23

18:19

Page 5



DNV.ID26559

CRETE CEMENT

ID	DES	MASS t	DENS t/m3	FILL %	LCG m	TCG m	VCG m	FRSM tm
-----								
CONTENTS : STO=Stores (RHO=1)								
BSN	Bosun Store	0.0	1.000	0.0	86.64	0.00	9.28	0
CONTENTS : MASS= (RHO=0)								
(UNKNOWN_.		118.1	0.000	0.0	35.97	4.29	5.63	0
CONTENTS : VOID=Void (RHO=1.025)								
VSA	Void	0.0	1.025	0.0	13.03	0.00	9.27	0
VS#6	Void	0.0	1.025	0.0	2.78	0.13	7.10	0
CD#15	Void	0.0	1.025	0.0	17.24	-0.06	0.84	0
VS-CH1	Void	0.0	1.025	0.0	73.30	0.00	2.56	0
VS-CH2P	Void	0.0	1.025	0.0	54.28	-4.15	1.47	0
VS-CH2S	Void	0.0	1.025	0.0	54.28	4.15	1.47	0
VS-CH3P	Void	0.0	1.025	0.0	31.34	-3.90	1.54	0
VS-CH3S	Void	0.0	1.025	0.0	31.34	3.90	1.54	0
VS117P	Void	0.0	1.025	0.0	83.12	-1.14	1.47	0
VS117S	Void	0.0	1.025	0.0	83.12	1.14	1.47	0
COFF#57	Coff.above HF.	0.0	1.025	0.0	41.90	0.00	7.39	0
CD-H2S	Void	0.0	1.025	0.0	56.97	7.35	8.01	0
CD-H2P	Void	0.0	1.025	0.0	56.97	-7.35	8.01	0
CD-H3S	Void	0.0	1.025	0.0	32.47	7.49	8.00	0
CD-H3P	Void	0.0	1.025	0.0	32.47	-7.49	8.00	0
PASP	Passage Way P	0.0	1.025	0.0	57.32	-6.63	6.30	0
PASS	Passage Way S	0.0	1.025	0.0	57.32	6.63	6.30	0
CD-H1C	Void	0.0	1.025	0.0	75.97	0.00	8.14	0
-----								
SUBTOTAL		0.0			0.00	0.00	0.00	0
CONTENTS : WB=Water Ballast (RHO=1.025)								
FPT	01 Fore Peak	0.0	1.025	0.0	86.58	0.00	5.75	0
WBT1P	WB02.P	0.0	1.025	0.0	72.06	-3.32	1.08	0
WBT1S	WB03.S	0.0	1.025	0.0	72.06	3.32	1.08	0
WBT2P	WB04.P	0.0	1.025	0.0	59.57	-6.88	2.06	0
WBT2S	WB05.S	0.0	1.025	0.0	59.57	6.88	2.06	0
WBT3P	WB06.P	0.0	1.025	0.0	46.80	-6.92	2.04	0
WBT3S	WB07.S	0.0	1.025	0.0	46.80	6.92	2.04	0
WBT4P	WB08.P	0.0	1.025	0.0	32.13	-6.86	2.06	0
WBT4S	WB09.S	0.0	1.025	0.0	32.13	6.86	2.06	0
WBT5P	WB10.P	2.3	1.025	2.4	74.22	-4.91	2.04	102
WBT5S	WB11.S	2.3	1.025	2.3	74.22	4.91	2.04	108
-----								
SUBTOTAL		4.7			74.22	-0.00	2.04	210
-----								
TOTAL		5393.0			48.60	0.06	5.38	464



### STABILITY SUMMARY

=====

### CRITERIA LIST

Environment: INTACT  
Criteria group: CR\_I Defaults

### LOADING CONDITION ER#GROUNDING08#1-TMP, Cond.5 Full.Arr

Heel (deg)	0.8	5.0	10.0	20.0	30.0	40.0	45.0
KN (m)	0.092	0.578	1.138	2.257	3.260	4.105	4.472
dGZ (m)	0.001	0.004	0.006	0.010	0.014	0.019	0.021
GZ (m)	0.01	0.08	0.15	0.31	0.42	0.45	0.45
e(phi) (mrad)	0.000	0.004	0.014	0.054	0.119	0.196	0.235

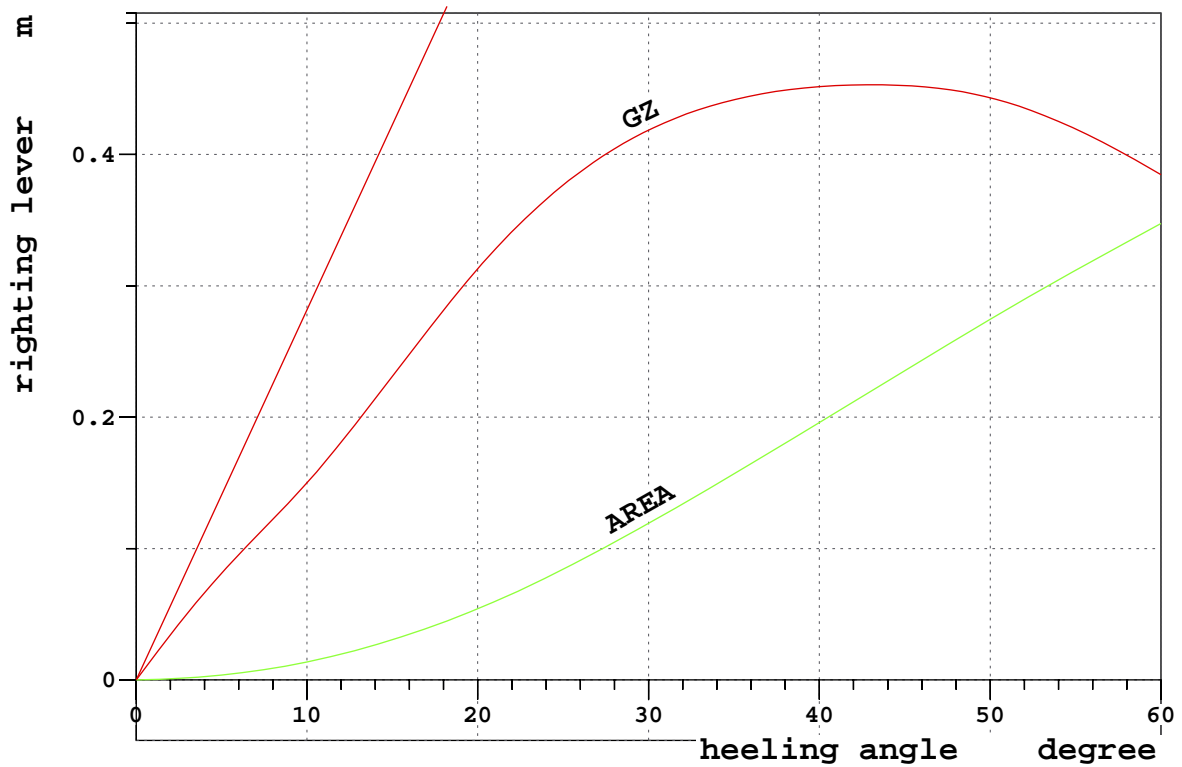



### STRENGTH SUMMARY

=====

LOADING CONDITION ER#GROUNDING08#1-TMP, Cond.5 Full.Arr

		POSITION:	X	FRAME
SHEAR FORCE (MIN)	-164.2 t		67.8 m	96
SHEAR FORCE (MAX)	185.9 t		11.1 m	15
MAX. REL. SHEAR FORCE	30.1 %		11.1 m	15
SAGGING MOMENT	-3.5 tm		91.6 m	132
HOGGING MOMENT	4124.1 tm		41.9 m	59
MAX. REL. SAGGING MOMENT	-			
MAX. REL. HOGGING MOMENT	42.1 %		17.3 m	24

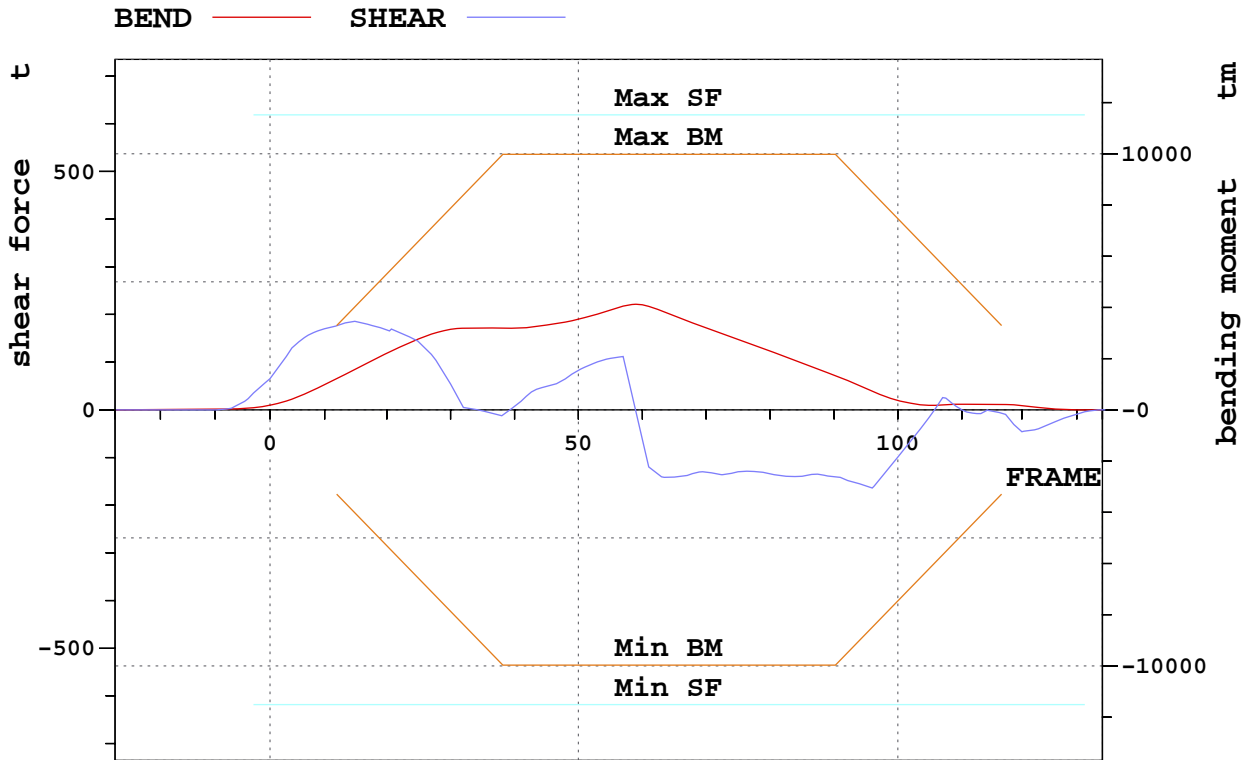

## **SÆRAVTALE FOR ARBEIDSTAKERE SOM GJØR TJENESTE SOM STATSLOSER OG STATSLOSASPIRANTER I KYSTVERKET**

### **§ 1 Parter**

1. Parter etter denne særavtalen er Kystverket og Norsk Losforbund.

### **§ 2 Virkeområde**

1. Særavtalen omfatter alle statslosere som er ansatt i Kystverket. Alle statslosere er statstjenestemenn. En statsloser er en ansatt som har gjennomført opplæringstid som statslosaspirant og som har avlagt 1. deleksamen.
2. Særavtalen omfatter alle statslosaspiranter som er ansatt i Kystverket.

### **§ 3 Varighet**

1. Særavtalen gjelder fra og med 01.11.2008 til og med 31.10.2010.
2. Denne avtalen erstatter alle tidligere avtaler med særavtaleinnhold som omhandler statslosere.

### **§ 4 Formål**

1. Særavtalen skal bidra til å skape gode samarbeidsvilkår mellom Kystverket og Norsk Losforbund.
2. Særavtalen skal bidra til å skape godt samarbeid mellom Kystverket som arbeidsgiver og statslosere og statslosaspiranter som arbeidstakere slik at alle årsverk blir levert som forutsatt og at alle arbeidsoppgaver kan utføres på en sikker og god måte i et godt arbeidsmiljø.
3. Særavtalen skal bidra til å skape god forutsigbarhet på personalområdet for både Kystverket som arbeidsgiver, for Norsk Losforbund som arbeidstakerorganisasjon og for alle ansatte statslosere og statslosaspiranter som arbeidstakere.
4. Særavtalen skal bidra til å fremme effektivitet i arbeidet og økt produktivitet blant statslosaspiranter og statslosere. Økt effektivitet i tjenesten er av avgjørende betydning for særavtalens innhold. Det forventes økt effektivitet med de insentiver som ligger i særavtalen i form av økt brotid, mindre relativ bruk av overtid og mindre relativ reisetid.

## § 5 Arbeidstid

1. Arbeidstid defineres som losingstid, reisetid, uforutsett ventetid, samt administrativt arbeid i forbindelse med tilvist losingsoppdrag under forutsetning av at reisetiden og/eller ventetiden ikke nyttes til hvile, samt annet administrativt arbeid for de statsloser som har administrativt arbeid som del av sine arbeidsoppgaver.
2. Den årlige arbeidstiden for statslosaspiranter og statsloser uten rett til å avvikle den 6. ferieuke baseres på gjennomsnittsberegning med 131 vakt døgn pr. år. Den enkelte statslos står da til disposisjon 24 timer pr. døgn i vaktperiodene med uttak av 12 timers arbeidstid pr. 24 timer. Dette gir et faktisk årsverk på 1572 timer. Dette utgjør en full stilling, jf. HTA Fellesbestemmelsene § 7 nr. 3.
3. Den årlige arbeidstiden for statsloser med rett til å avvikle den 6. ferieuke tar utgangspunkt i den samme arbeidstidsordning som for andre statsloser. Den 6. ferieuke avvikles etter lovlig varsel til arbeidsgiver.
4. Losoldermannen setter opp vaktplaner i samråd med tillitsvalgte. Vaktplaner skal så langt som mulig tilpasses trafikkmønsteret ved den enkelte losstasjon.
5. Ferie og fritid for statslosaspiranter og statsloser avvikles i løpet av de 33 uker og 2 dager av kalenderåret de ikke har vaktperioder. De særlige lovbestemte regler om den 6. ferieuke ivaretas.
6. Brotjeneste
  - a. Av sikkerhetshensyn kan en statslos ikke pålegges sammenhengende aktiv brotjeneste i mer enn 10 timer.
  - b. For oppdrag som påbegynnes mellom kl 20:00 og kl 06:00 kan en statslos ikke pålegges sammenhengende aktiv brotjeneste i mer enn 9 timer, jf. for øvrig loslovens § 10.
  - c. Med aktiv brotjeneste forstås den tid som losen utøver losingsarbeid på broen, herunder i kompensasjonssammenheng, også opplæring av statslosaspiranter.
  - d. Ved tomannslosing blir aktiv brotjeneste satt lik oppdragstiden delt på 2.

## § 6 Lønnplassering

1. Statsloser avlønnes etter lønnsplan 03.215 med stillingskode 0111.
2. Statslosaspiranter lønnes i stillingskode 1335 – LR 12, alt. 12.
3. Statsloser med tjenestested ved losstasjoner i Finnmark (Honningsvåg, Hammerfest, og Kirkenes) gis et tillegg på B-tabellen - ltr. 15.

4. Statsloser med tjenestested ved Fedje, Slagentangen, Narvik (og statsloser som er utsjekket for stortonnasje og som gjør oppdrag i Narvik), Sarpsborg og/eller Halden, samt Tananger gis et tillegg på B-tabellen – ltr. 25.
5. Statsloser ved Bergen og Viksøy losstasjon som er sjekket ut for stortonnasje til Mongstad og Sture gis et tillegg på B-tabellen – ltr. 25. Arbeidsgiver setter opp lister over statsloser som inngår i denne ordningen. I dette ligger at statslosen, etter arbeidsgivers anvisning, ved behov utfører tjeneste ved Fedje herunder kan inngå i tørnlisten for Fedje.
6. Statsloser ved Ålesund, Fedje, Bergen og Viksøy losstasjon som utfører tjeneste ved Florø losstasjon gis et tillegg på B-tabellen – ltr. 25. Arbeidsgiver setter opp lister over statsloser som inngår i denne ordningen. I dette ligger at statslosen, etter arbeidsgivers anvisning, ved behov utfører tjeneste ved Florø herunder kan inngå i tørnlisten for Florø.
7. Statsloser med tjenestested Fedje og de som gjør tjeneste som omtalt i nr. 5 som inngår i ordningen omtalt i nr. 6 gis et samlet tillegg på B-tabellen – ltr. 35.
8. Alle B-tillegg i denne paragrafen faller helt eller delvis bort ved endring av tjenestested og/eller deltakelse i ordningene omtalt i nr. 5. og nr. 6.

## § 7 Overtid

1. All bruk av overtid skal være pålagt.
2. Når bemanningen ved en stasjon er under minimum (se § 12 nr. 5), tas det inn loser i avtørn på vaktplanen. Dette kompenseres med overtidsgodtgjørelse.
3. I perioder hvor etterspørselen etter lostjenester er stort, for eksempel i cruise sesongen, er det fra begge parter side ønskelig med større forutsigbarhet. Losoldermannen kan derfor etter avtale med tillitsvalgt og med samtykke fra den enkelte los setter opp lister over loser som på overtid blir tatt inn på vaktplanen.
4. Arbeidsgiver kan pålegge statslos overtid i vaktperioden der hvor tiden blir benyttet til reise frem til nytt oppdragssted. Arbeidsgiver vurderer dette i hvert enkelt tilfelle.
5. Ved utkalling på overtid skal trekk av hviletid ikke overstige 1/3 av den totale tid losen er pålagt overtid. Pålagt overtid er også den tid vedkommende står på tørnliste.

## § 8 Overtidsgodtgjørelse

1. Overtidsgodtgjørelse er vanlig timelønn tillagt 50 %.
2. Forhøyet overtidsgodtgjørelse er vanlig timelønn tillagt 100 %.
3. Pålagt tjeneste utenom vaktperioder kompenseres med forhøyet overtidsgodtgjørelse.

4. Statsloser som utkalles på overtid på ukefriday utbetales minimum en total kompensasjon som tilsvarer 4 timer forhøyet overtidsgodtgjørelse. Denne godtgjørelse utbetales i disse tilfeller også ved kansellering av oppdraget. Hvis arbeidet avbrytes, betales ikke ekstra for nytt overtidsarbeid dersom dette på begynnes innenfor de beregnede 4 timer.

## § 9 Tilleggs lønn

1. Statsloser med avlagt 1. deleksamen utbetales et tillegg på B 110 + B 32 til dekning av forhold forbundet med tjeneste på lørdager, søndager, helge- og høytidsdager, nattarbeid m.v.
2. Statsloser med bestått siste deleksamen utbetales et tillegg på B 110 + B 64 til dekning av forhold forbundet med tjeneste på lørdager, søndager, helge- og høytidsdager, nattarbeid m.v.
3. Det utbetales et brotillegg på NOK 110,- pr. time for aktiv brotjeneste i tidsrommet mellom kl. 06.00 og 20.00.
4. Det utbetales et brotillegg på NOK 160,- pr. time for aktiv brotjeneste i tidsrommet mellom kl. 20.00 og kl. 06.00.
5. Det utbetales et tillegg for bording/kvitting med losbåt på NOK 160,- pr. bording/kvitting.
6. Det utbetales et tillegg for bording/kvitting med helikopter på NOK 430,- pr. oppdrag.

## § 10 Kostgodtgjørelse

1. Kostgodtgjørelse gis i henhold til Særavtale for reiser innenlands for statens regning for hele inntektsåret.
2. Alternativt kan fast kostgodtgjørelse gis med NOK 2.175,- pr. måned under forutsetning av at dette skriftlig er meddelt losoldermannen (avdelingssjefen) senest 1. desember året før.
3. Statsloser som utkalles på ukefriday og som oppebærer kronetillegg etter nr. 2, får dekket kostgodtgjørelsen i henhold til Særavtale for reiser innenlands for statens regning. Reisetid beregnes fra bopel.
4. Det kan beregnes sammenhengende kostgodtgjøring hvis ventetiden mellom to losoppdrag ikke overstiger 1/2 time.

## § 11 Reisegodtgjørelse

1. Legitimerte reiseutgifter i forbindelse med oppdrag eller annen tjeneste refunderes med hjemmel i særavtale for reiser innenlands for statens regning.
2. Utgangspunkt/endepunkt for reisen er den enkelte statslos' tjenestested. Reiseutgifter/kost kan beregnes fra bopel når bopel ligger innenfor en strekning langs vei på 60 km fra tjenestestedet, dog ikke ut over en reisetid på 2 timer med offentlig kommunikasjonsmidler eller egen transport.
3. Egen bil kan benyttes hvis alternativet er dyrere, jf. SPH pkt. 9.2.6.
4. Ved utkalling til overtid i avspaseringsperioden dekkes reiseutgifter fra bopel.
5. Dersom ikke arbeidsgiver stiller tilfredsstillende kvarter til disposisjon, kan det beregnes ulempetillegg med NOK 400,-. Statslosene kan ikke kreve kvarter for hvile av oppdragsgiver dersom det skal arbeides kontinuerlig under oppdraget. På tomannslosing av cruiseskip betales kun ulempetillegg når to statsloser må dele lugar.
6. Statslosen får dekket legitime utlegg til dagopphold på minst 3 timer dersom timene går til fradrag i arbeidstiden (hviletid). Ulegitimerte utlegg til dagopphold på minst 3 timer dekkes med NOK 400,- dersom timene går til fradrag i arbeidstiden (hviletid).
7. En los som søker seg fra en losstasjon til en annen losstasjon får i forbindelse med opplæringen dekket reiseutgifter etter statens reiseregulativ innenfor omsøkt sertifikatområde.

## § 12 Andre bestemmelser

1. Arbeidsgiver dekker dokumenterte utgifter til ett par reservebriller til statsloser for bruk om bord. Brillerglass dekkes fullt ut, samt innfatninger med øvre prisgrense NOK 1.000,-. Med reservebriller menes brillepar nummer 2 ved nykjøp av briller.
2. På tider av året der tjenesten tillater det kan statsloser ta seg annet lønnet arbeid når det ikke strider mot de regler som er omtalt i Statens personalhåndbok om bierverv og ekstraerverv for statstjenestemenn.
3. Statsloser som gjør tjeneste som fadder for losaspiranter utbetales NOK 4.000,- pr. måned i det tidsrommet denne tjenesten utføres.
4. Statsloser utbetales uniformsgodtgjørelse på NOK 5.000,- pr. år. Losjakker (sommer/vinter) utleveres ved tiltredelse og fornyes med en slitetermin på 3 år.
5. Losoldermannen må i samarbeid med de tillitsvalgte definere minimumsbemanning ved hver losstasjon. Med minimumsbemanning menes her minimum antall loser på vakt til enhver tid.
6. For hver statslosaspirant utbetaler Kystverket NOK 20.000,- til Norsk Losforbund etter fullført opplæring.
7. Tørnreiser dekkes med inntil NOK 5.000,- tur/retur.



8. For avtalt ekstra uttak av 6 dagers tjeneste utbetales 2 lønnstrinn på A-tabellen første året og 2 nye lønnstrinn på A-tabellen andre året, og deretter 1 lønnstrinn på A-tabellen hvert år så lenge ordningen varer.

Ålesund, 30.10.2008



Vigdis T. Bye  
Avdelingsdirektør  
Økonomi- og administrasjonsavdelingen  
Kystverket

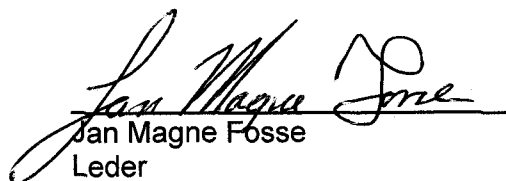

Jan Magne Fosse  
Leder  
Norsk Losforbund

## Annex E

### Overview of the current status of production of temporary (T) and preliminary (P) notices for each nation

In order to inform the users about the status of production of T&P notices in the ENC update files, the two RENCs have collected information from the individual HOs distributing ENCs through the RENCs. The result is presented in the table below.

Nation	T (Temporary) notices included in EN/ER files	P (Preliminary) notices included in EN/ER files	Additional comments
Argentina	Yes	Yes	Notices to Mariners including Temporary and Preliminary Notices, if any, are published in the Servicio de Hidrografia Naval webpage ( <a href="http://www.hidro.gov.ar">www.hidro.gov.ar</a> ).
Belgium	No	No	Temporary and Preliminary notices are found in NtM booklet paper or website: <a href="http://www.vlaamsehydrografie.be/welkom.aspx">http://www.vlaamsehydrografie.be/welkom.aspx</a>
Canada			
Croatia	Yes	Yes	
Denmark	Yes/No	Yes/ No	P & T notices will be included if necessary but is considered case by case.
Estonia	Yes	No	
Finland	Yes	Yes/ No	P notices can be included if necessary but it is considered case by case.
France	No	No	NtM booklet section 1.3 (paper or website : <a href="https://www.shom.fr/GanHtdocs/">https://www.shom.fr/GanHtdocs/</a> )
Germany	Yes	Yes	
Greece	No	No	
Iceland	No	No	Temporary and Preliminary notices are found in NtM booklet paper or website: <a href="http://www.lhg.is/starfsemi/sjomaelingasvidts/">http://www.lhg.is/starfsemi/sjomaelingasvidts/</a>
Italy	No	No	Temporary notices are found in NtM booklet section B2 and C (paper or website: <a href="http://www.maridrografico.genova.marina.difesa.it">http://www.maridrografico.genova.marina.difesa.it</a> Can link to Avvisi ai Naviganti from here
Japan	No	No	see NtM booklet section 3 or website ( <a href="http://www.kaiho1.mlit.go.jp/TUHO/tuho/html/tuho/keiho_index.html">http://www.kaiho1.mlit.go.jp/TUHO/tuho/html/tuho/keiho_index.html</a> )
Korea	No	No	
Malacca. and Singapore	Yes	Yes	

<b>Nation</b>	<b>T (Temporary) notices included in EN/ER files</b>	<b>P (Preliminary) notices included in EN/ER files</b>	<b>Additional comments</b>
Straits			
Netherlands	No	No	Temporary and Preliminary notices are available via our chart agents and can also be found on our website: <a href="http://www.hydro.nl/pdfs/PT_NTm.pdf">www.hydro.nl/pdfs/PT_NTm.pdf</a>
Norway	No	No	Temporary and Preliminary notices are found in NtM booklet paper or website: <a href="http://www.statkart.no/efs/efs.html">http://www.statkart.no/efs/efs.html</a>
Poland	Yes- but only the most important from navigational point of view	No	The Polish NtM you can find - <a href="http://bhmw.mw.mil.pl/">http://bhmw.mw.mil.pl/</a>
Portugal	No	No	Temporary and Preliminary notices are found in paper NtM booklet or website: <a href="http://www.hidrografico.pt/ldamar/AnavNet/ENC-En.aspx">http://www.hidrografico.pt/ldamar/AnavNet/ENC-En.aspx</a>
Russia	No	No	
South Africa.	Yes	Yes	Also contained in our Monthly Notices to Marines publication, available on our web site <a href="http://www.sanho.co.za/">http://www.sanho.co.za/</a>
Spain	Yes	No	
Sweden	No	No	Temporary and preliminary notices are found:  <a href="http://www.sjofartsverket.se/templates/SFVXIFramePage_5302.aspx">http://www.sjofartsverket.se/templates/SFVXIFramePage_5302.aspx</a>
South China Sea ENC	Yes	Yes	
Turkey	No	No	T & P notices are found in NtMs booklet paper or website: <a href="http://www.shodb.gov.tr">http://www.shodb.gov.tr</a>
United Kingdom	Yes	Yes	Temporary and Preliminary notices can also be found in NtM booklet or website: <a href="http://www.ukho.gov.uk">www.ukho.gov.uk</a>
USA	No	No– not published in the US	Temp notices are found: <a href="http://www.navcen.uscg.gov/lnm/default.htm">http://www.navcen.uscg.gov/lnm/default.htm</a>  Can link to the Canadian Notices and to the NGA National Notices from here

## Annex F

Bergen, 8.10.09

### Faglig vurdering av Crete cement-ulykken

Det er store forskjeller fra person til person i søvnlengde, søvnbehov og tretthet/søvnighet. Noen trenger mye søvn for å fungere på dagtid, mens andre langt mindre. Man skal derfor være forsiktig med å vurdere hvor mye søvn en enkelt person må ha for å bli uthvilt. Likevel viser forskning at de aller fleste sover 6 timer eller mer per natt. Det vil si at sover man mindre enn 6 timer kan det sees på som uvanlig lite, og noe som ofte assosiert med nedsatt funksjon på dagtid.

Det er videre viktig å skille mellom begrepene ”tretthet” og ”søvnighet”. Mange bruker disse begrepene om hverandre. Søvnighet peker på faren for å sovne av, mens tretthet er et mer uspesifikt begrep. Det er mulig å være trett, uten å være søvnig. Hvis man for eksempel har vært på en hard treningstur vil man kunne føle seg veldig trett, men samtidig være våken og klar (og uten risiko for å sovne av). Søvnighet er noe man ser hvis man har søvnunderskudd, for eksempel hvis man har sovet lite. Personen vil da føle et behov for å duppe av/sovne. Tretthet kan skyldes en rekke faktorer, ikke bare lite eller dårlig søvn. Det betyr at man kan være trett selv om søvnen har vært normal/god. I denne aktuelle saken er det søvnighet som spiller størst rolle.

Grad av søvnighet viser en tydelig døgnrytme. Det betyr at søvnigheten ikke bare er avhengig av hvor mye søvn man har fått, men vel så mye hva klokken er når søvnigheten skal bestemmes. Ved å studere nattarbeidere sees bl.a. at under normale forhold øker søvnigheten fra ca. kl. 23 fram til et makspunkt ca. kl. 05 om natten, for deretter å reduseres utover morgenen/formiddagen. Dette kan fremstilles grafisk, se under. Her sees endringene i kroppstemperaturen, og grad av våkenhet følger samme kurve. Det vil si at ca. kl. 05 vil de fleste ha størst problemer med å holde seg våkne. Det gjelder hos personer med normal døgnrytme. For B-mennesker vil dette tidspunktet for maks søvnighet være senere på morgenen, mens for A-menneskene tidligere.

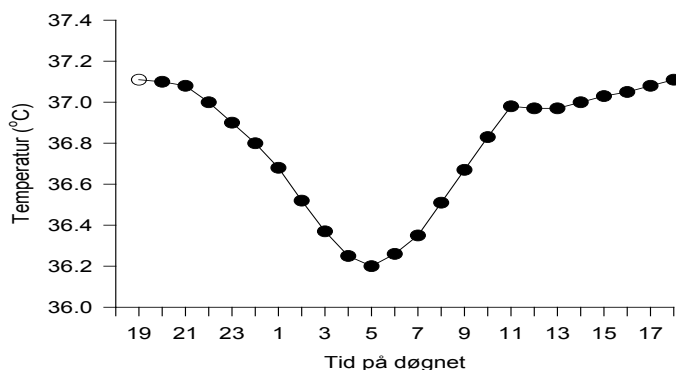

Flere vitenskapelige undersøkelser viser at risikoen for uhell eller feil er økt rundt dette makspunktet og de første 1-2 timer etterpå. Dvs i 5-6-tiden på morgenkvisten for en person med normal døgnrytme. Dette er ikke overraskende; ekstrem søvnighet gir nedsatt prestasjonsevne.

Studier har sammenliknet prestasjonsnivået ved inntak av alkohol med antall timer i våken tilstand. Ved alkoholinntak sees en gradvis reduksjon i prestasjonsnivået avhengig av promillen til den enkelte. Ved søvndeprivasjon (=uten søvn) sees liten endring i prestasjonsnivået i løpet av de første ca. 16 timene med sammenhengende våkenhet. Men etter 17-18 timer uten søvn sees et prestasjonsnivå tilsvarende en promille på 0,5, og etter 24 timer uten søvn er prestasjonsnivået tilsvarende en promille på 1,0. Prestasjonsnivået er her testet ved hjelp av reaksjonstestmålinger. Dette betyr at evnen til å fungere optimalt reduseres kraftig uten søvn, og nedsatte prestasjoner (feil/uhell) sees spesielt sent på natten/tidlig om morgenen. Og effekten på prestasjonsevne kan sammenliknes med å være beruset.

Slike undersøkelser som nevnt over er gjort under kontrollerte og standardiserte forhold. I arbeidslivet vil arbeiderne prøve å kompensere økt søvnighet/reduisert prestasjonsevne med ulike tiltak. For eksempel vil inntak av koffein (kaffe, te, cola) kunne redusere søvnigheten. Andre metoder er å skru opp lyset, bevege seg rundt, snakke med kolleger etc. Ingenting er imidlertid mer effektivt enn en liten høneblund. Kortvarige søvnepisoder reduserer søvnigheten effektivt. Men dette kan ikke erstatte viktigheten av å oppnå god søvn – hver natt.

I forbindelse med nattarbeid har flere undersøkelser vist at nattarbeidere kan falle i kortvarig søvn, uten at de selv er klar over det. Det er dette som er så farlig i trafikken. Bil/buss/togføreren kan gjerne kjenne seg trett på forhånd, men søvnen kan likevel komme uventet og plutselig. Studier med simulert bilkjøring viser at personer kan "sove" med øynene åpne, og uten at de selv registrerer at de sover. Øynene kan i slike tilfeller bli noe blasse, og virke fjerne, men det er ikke et krav at man må ha lukkede øyne for å si at det er søvn. Det kalles gjerne mikrosøvn, hvis søvnperioden er kortvarig (ofte definert som under 15 sekunder i varighet). Men lengre søvnperioder kan også sees, uten at personen på forhånd merker tydelige forvarslar.

Svar på de spesifikke spørsmålene:

- 1. Kan tretthet og eventuelt mikrosøvn være en medvirkende faktor til "ble borte" perioden på ca. 70-90 sekunder, som losen hadde på ulykkestidspunktet? Hva taler for og imot det av det man vet fra forskning på ditt felt*

Ja, lite søvn og økt søvnighet kan resultere i at en arbeider kan sovne av, selv i stående posisjon med åpne øyne. Det vil neppe kalles mikrosøvn hvis episoden var så lang som 70 sekunder, da snakker vi mer om ordinær søvn. Men det er mulig at han var i søvn en kortere periode, og at han var delvis våken resten av perioden, men fremdeles med redusert evne til å vurdere hva som skjedde. Det som taler for er at han har hatt lite søvn de siste dagene før hendelsen. I følge arbeidstidsskjemaet har muligheten for søvn vært svært begrenset den siste uken. I tillegg har friperiodene vært varierende i varighet, og det synes som om han har måttet sove delvis på dagtid og av og til på tidspunkt hvor søvn vanligvis er vanskelig å få til. Et annet viktig moment som taler for at søvn/søvnighet kan være en medvirkende faktor er at ulykken skjedde kl. 06.40. Ut fra det vi vet om døgnrytmeregulering er det et tidspunkt hvor

uhell/ulykker lettere kan inntreffe, fordi søvnigheten er klart økt da. Han hadde da gått flere timer uten søvn, og var på et tidspunkt hvor mange nattarbeidere rapporterer problematisk søvnighet. Ved underskudd på søvn fra dagene før vil denne søvnigheten på morgenkvisten forsterkes.

Det som vil kunne tale mot at søvnighet/søvn spiller en rolle for ulykken vil være personlige egenskaper hos arbeidstakeren. Hvis han er en person som takler lite søvn og uregelmessig døgnrytme veldig godt, vil hans risiko for å sovne være klart redusert. Enkelte takler nattarbeid og uregelmessig skiftordninger godt, og faren for uhell er relativt lav.

*2. Kan arbeidstiden til losen i forveien av ulykken være medvirkende til eventuell tretthet? Hva taler for og imot det av det man vet fra forskning på ditt felt*

Ja, slik jeg leser arbeidstiden hans siste uke har det vært svært lite muligheter for søvn. Vaktperiodene har kommet tett og uregelmessig. Tiden han har hatt hjemme til søvn har vært svært begrenset, og ofte har han måtte sove på tider av døgnet hvor søvn vanligvis er vanskelig å få til, for eksempel i tidsrommet kl 20-22 (the sleep forbidden zone). Det er viktig at nattarbeid etterfølges av tilstrekkelig tid til å restituere seg. Jeg kan ikke se at losen har hatt nok anledning til det siste uken før ulykken. Dette betyr at han sannsynligvis har opparbeidet seg et stort søvnunderskudd i dagene forut for hendelsen. Dette vil åpenbart kunne øke faren for at han sovner på jobb. Og da spesielt i 5-6-tiden om morgenen.

Litteratur:

Bjorvatn B, Pallesen S. A practical approach to circadian rhythm sleep disorders. *Sleep Med Rev*, 2009; 13: 47-60.

Philip P, Akerstedt T. Transport and industrial safety, how are they affected by sleepiness and sleep restriction? *Sleep Med Rev*, 2006; 10: 347-56.

Rajaratnam SM, Arendt J. Health in a 24-h society. *Lancet*, 2001; 358: 999-1005.

Van Dongen HP, Maislin G, Mullington JM, Dinges DF. The cumulative cost of additional wakefulness: dose-response effects on neurobehavioral functions and sleep physiology from chronic sleep restriction and total sleep deprivation. *Sleep*, 2003; 26: 117-26.

Van Dongen HP, Baynard MD, Maislin G, Dinges DF. Systematic interindividual differences in neurobehavioral impairment from sleep loss: evidence of trait-like differential vulnerability. *Sleep*, 2004; 27: 423-33.

Med vennlig hilsen

Bjørn Bjorvatn  
Professor, dr.med.  
Universitetet i Bergen  
og  
Leder, Nasjonalt Kompetansesenter for Søvn sykdommer  
Haukeland Universitetssykehus

 <b>KYSTVERKET</b>	<b>Kapittel 7</b> <b>INSTRUKSER OG BESTEMMELSER</b>  <b>7.8 Tjenesteinstruks for statsloser</b>	Dok. nr. MT-HB-7.8
		Rev. 0
		Dato: 09.01.2006
		Utgitt av: Sentral Los/VTS
		Side 1 av 2

## 7.8 Tjenesteinstruks for statsloser

Instruksen er vedtatt av Kystdirektoratet 2. desember 1991, og trer i kraft 1. januar 1992. Punkt 6 er endret pr. 10. februar 1992. I Kgl. res. av 27. september 1991 er det fastsatt at Tjenesteinstruksen, ved ikrafttredelsen, opphever «Forskrift om tjenesteinstruks for losvesenet», som er gitt i Kgl. res. av 25. august 1967.

1. En statslos skal ta den losing han blir tilvist (jf. instruksens punkt 4). Ingen statslos må ta losoppdrag fra andre enn losformidlingsapparatet, og ikke lose istedenfor en annen uten samtykke fra losoldermannen, eller den han bemyndiger.
2. Under losing skal losen bære uniform etter det til enhver tid gjeldende reglement, samt ha med Kystverkets identitetskort. Uniform skal også bæres ved deltagelse i offisielle anledninger, f.eks; befaringer, loseksamen, representasjon m.v.
3. En statslos plikter å søke opplysninger hos losoldermannen/losformidlingstjenesten om skipet og losoppdraget slik at han er best mulig forberedt for oppdraget.
4. En statslos plikter å gjøre sin foresatte oppmerksom på forhold som kan medføre at et tilvist losoppdrag ikke vil kunne gjennomføres med sikkerhet, herunder forhold som egen kompetanse, sykdom og tretthet, samt forhold ved fartøy og besetning m.v. En statslos skal ikke påta seg et losoppdrag han ikke selv anser seg kompetent eller skikket til å utføre.
5. En statslos skal i vaktperioden holde losformidlingsapparatet informert om utførelsen av oppdraget mv., så som ankomststidspunkt for fartøyet, oppholdssted, planlagt reise og andre forhold av betydning, slik at formidlingsentralene kan disponere ressursene på en mest mulig effektiv måte.
6. Statslos med mindre enn 3 års tjenestetid kan lose fartøyer med største lengde inntil 120 meter og største dypgående inntil 7 meter. Nyutdannede statsloser som har fulgt trinnvis opplæring, kan etter første deleksamen lose fartøyer med største lengde inntil 105 meter og største dypgående inntil 6,5 meter. Etter andre deleksamen og fram til 2 år etter siste deleksamen er avholdt, og losen er fast tilsatt, kan losen lose fartøyer med største lengde inntil 120 meter og største dypgående inntil 7 meter. Det distriktskontor som losen hører inn under, kan dispensere fra disse grensene.
7. Når en statslos er kommet ombord for å lose, skal han søke de opplysninger om fartøyet hos skipsføreren som er av betydning for oppdraget. Det tenkes spesielt på at det er nødvendig å avklare eventuelle avvik mellom informasjon gitt av formidlingstjenesten/megler og de faktiske forhold ombord. Dette kan gjelde dypgående, bredde, lengde, høyde, fart, last og eventuelle andre forhold som kan ha innflytelse på sikker seilas. Jf. rundskriv LB 16/85 av 30. juni 1985. Vesentlige avvik fra gitte opplysninger skal tilbakemeldes til losformidlingstjenesten.
8. Dersom et skip av sikkerhetsmessige årsaker må dirigeres lenger inn enn det normale bordingsfelt, plikter losen hvis mulig, også når ombord i losbåten, å rettledede skipet med de hjelpemidler han rår over inntil bording kan finne sted. Likeledes om losen må debarkere i annen posisjon enn bordingsfeltet plikter losen å rettledede skipet frem til normalt bordingsfelt fra losbåten. Losen kan i spesielle tilfeller, når det teknisk er lagt til rette for det, bli pålagt å veilede fartøyet med radar fra landsentral (losing over distanse).
9. Losen skal være på brua under hele seilassen, med unntak av korte, nødvendige ærend. Dersom ansvarshavende offiser overtar navigeringen eller manøvreringen av fartøyet, skal losen normalt fortsatt være tilstede på brua som rådgiver. Dette medmindre oppdraget er av en slik varighet at losen må hvile underveis. Slike oppdrag kan kun gjennomføres etter overenskomst mellom skipsfører/mekler og losoldermann i forbindelse med losbestilling.
10. Losen skal gi råd om bruk av taubåt i de tilfelle taubåtsassistanse ikke følger av seilingsregler. Dersom kapteinen ikke tar losens råd til følge ved ikke å ta taubåt, evt. bestille taubåtkapasitet som ikke fyller de sikkerhetsmessige krav som losen stiller, kan losen kreve seg fritatt for manøvrering. Han skal likevel være tilstede på brua og bidra med opplysninger og assistanse til skipsfører.
11. Losen plikter å opplyse navn og sertifikatnr. på forespørsel fra off. myndighet.
12. Losen plikter å påse at skjemaer som skal nyttes i forbindelse med losoppdrag blir riktig utfylt.

 <b>KYSTVERKET</b>	<b>Kapittel 7</b> <b>INSTRUKSER OG BESTEMMELSER</b>  <b>7.8 Tjenesteinstruks for statsloser</b>	Dok. nr. MT-HB-7.8 Rev. 0 Dato: 09.01.2006 Utgitt av: Sentral Los/VTS Side 2 av 2
---	--	--

13. Dersom et fartøy med statslos ombord får ordre fra norsk forsvarspoliti,- eller tollmyndighet om å stoppe eller å foreta annen manøver og statslosen blir kjent med dette, plikter han å gjøre sitt til at ordren blir etterkommet. Han må i et slikt tilfelle ikke assistere fartøyets fører i annet enn den hensikt å etterkomme ordre som er gitt av vedkommende norske myndighet
14. Dersom et skip under veiledning av statslos blir utsatt for en ualminnelig hendelse, så som f.eks. grunnstøting eller kollisjon, skal losen ihht. retningslinjer for saksbehandling ved sjøulykker og uhell der statslos er involvert (Rundskriv LB 16/90 av 19. mars 1991), så snart råd er på fastsatt skjema melde fra til nærmeste foresatt. Melding skal gis selv om det inntrufne ikke har ført med seg skade på liv eller materiell, og enten fartøyet er norsk eller utenlandsk. Statslosen skal snarest mulig sørge for at nærmeste foresatte muntlig blir gjort kjent med hendelsen. Dersom en ualminnelig hendelse har inntruffet under utseiling fra riket og dersom hendelsen har eller antas å ha ført til skade på norsk liv eller eiendom, skal statslosen melde fra om dette. Han skal så avvente nærmere ordre om tillatelse for fartøyet til å forlate riket.
15. Enhver statslos plikter å gi godkjente losaspiranter instruksjon og faglig støtte under opplæring. På samme måte plikter enhver statslos å virke som instruktør for godkjente losaspiranter når særskilte farvannsbefaringer arrangeres av Kystverket. Det samme gjelder for instruktørtjeneste ved den teoretiske del av losutdanningen.



 <b>KYSTVERKET</b>	<b>Kapittel 7</b> <b>INSTRUKSER OG BESTEMMELSER</b>  <b>7.4 Instruks for losformidlingstjenesten</b>	Dok. nr. MT-HB-7.4
		Rev. 0
		Dato: 09.01.2006
		Utgitt av: Sentral Los/VTS
		Side 1 av 3

## 7.4 Instruks for losformidlingstjenesten

Fastsatt av Kystdirektoratet 19. august 1991, med virkning fra 1. september 1991.

### 1. Formål

Losformidlingstjenesten er en del av lostjenesten. Losformidlingstjenestens hovedoppgave er å sikre en effektiv, fleksibel og rasjonell utnyttelse av loskorpset innenfor rammen av gjeldende lov- og avtaleverk og øvrige gitte bestemmelser.

### 2. Instruksen gjelder for

- Losoldermennene
- Losformidlerene
- Statslosene
- Losbåtførerene
- Personell i trafikksentralene

### 3. Ansvarsområde

Losoldermannen disponerer alt personell nevnt under punkt 2, og har det overordnede administrative og operative ansvaret for at tjenesten fungerer i samsvar med formålet. Han skal påse at losene til enhver tid har gyldige sertifikater. I samråd med de tillitsvalgte skal han, om nødvendig, fastsette lokale detaljert bestemmelser om losformidlingstjenesten. Han bestemmer bruk av overtid ihht. gjeldene retningslinjer. Han skal dessuten føre statistikk etter nærmere bestemmelser.

Losformidleren skal:

- a. Registrere og journalføre losbestillinger.
- b. Planlegge disponeringen av vaktstyrken.
- c. Kontrollere at utenlandske fartøyer har lovlig adgang til norsk territorium ihht. Forskrift om fremmede ikke-militære fartøyers anløp av og ferdsel i norsk territorialfarvann under fredsforhold (FOR-1994-12-23-1130) og Forskrift om fremmede militære fartøyers og luftfartøyers adgang til norsk territorium under fredsforhold (FOR-1997-05-02-396), samt varsle politi/forsvar ved mistanke om at skip uten klarering går inn i norsk farvann.
- d. Prioritere oppdrag i samsvar med gitte bestemmelser.
- e. Tilvise losoppdrag etter nærmere bestemmelser (jf. pkt. 6), samt, om mulig skaffe los med dekkende sertifikat.
- f. Innhente relevante opplysninger om skipet og losoppdraget og formidle disse til losen i forbindelse med tilvisningen. Slike opplysninger kan være:
  - Skipstype
  - Registreringshavn (nasjon)
  - Skipets mål (lgd. bredde, maks.høyde)
  - Skipets fart
  - Dypgang
  - Last (jf. Skipperbeviset pkt. 17 a og 17 b)
  - Manøveregenskaper (baugpropell, Becker-ror o.l.)
  - Anløpssted
  - Kai, side til kai
  - Eventuelle opplysninger om havneforhold
  - Eventuelt bestilte taubåter
  - Eventuelt bestilt båtmann.
  - Los med begrenset sertifikat som er i losopplæringsfase disponeres etter spesielle kriterier.

 <b>KYSTVERKET</b>	<b>Kapittel 7</b> <b>INSTRUKSER OG BESTEMMELSER</b>  <b>7.4 Instruks for losformidlingstjenesten</b>	Dok. nr. MT-HB-7.4
		Rev. 0
		Dato: 09.01.2006
		Utgitt av: Sentral Los/VTS
		Side 2 av 3

(Jf. opplæringsplan lostjenesten).

- g. På losenes anmodning koordinere transport av los til/fra skip.
- h. På losens anmodning koordinere transport av los tilbake til stasjon, hjem eller nytt oppdrag, herunder bestilling av billetter når dette er aktuelt.
- i. På losens anmodning reservere hotellrom eller rom på losvakthus når dette er aktuelt.
- j. Føre oversikt over forbrukt arbeidstid for den enkelte los.
- k. Samle materiale for statistikk ihht. instruks.
- l. Føre oversikt over sertifikatdekningen for den enkelt los.

Statslosen skal:

- Gi losformidler beskjed ved endring av oppdrag
- Varsle losformidler ved avsluttet oppdrag

Losbåtførerne skal:

- Gi beskjed til losformidler ved uforutsette hendelser

#### 4. Tilvisning av losoppdrag

- a. Tilvisning av losoppdrag skjer som regel etter oppsatt tørnliste. Denne regel skal imidlertid fravikes når tjenestlige forhold tilsier det. Slike forhold kan være at:
  - en los bedømmer og tilkjennegir at han ikke har den nødvendige kompetanse for oppdraget
  - spesielle oppdrag forutsetter los med spesiell kompetanse
  - en los tilkjennegir at han ønsker oppdrag i spesielle farvann i den hensikt å vedlikeholde sitt sertifikat
  - et oppdrag med sannsynlighet vil overskride den lovbestemte arbeidstid
  - rasjonelle hensyn tilsier det, f.eks. ved returlosing eller dobbelt oppdrag, eller for å unngå dyre og tidsforbrukende fremreiser ved å tilvise oppdraget til en los som befinner seg i nærheten av skipet.

#### 5. Varsling

- a. En rasjonell, smidig, effektiv og sikker lostjeneste er for en stor del avhengig av planlegging. Dette gjelder også losens rolle. Så langt det er mulig skal losen være i en situasjon der han kan
  - planlegge hviletid
  - planlegge losoppdrag
  - planlegge fremreise
  - planlegge tilbakereise.
 En slik situasjon setter losen i stand til å yte maksimalt og være klar til nytt oppdrag på en raskest mulig måte. Det må derfor legges stor vekt på at varslings- og informasjonsrutiner mellom losformidlingstjeneste og los er gode og fleksible.
- b. Bosetning og fremreisemuligheter gjør at losene ofte vil ha forskjellige behov når det gjelder varslingstid. Den enkelte los må derfor ha anledning til å avtale med losformidlingstjenesten om hva slags varsling han ønsker. Dersom ikke annet er avtalt, skal losen under alle omstendigheter varsles minst 2 timer før oppdraget.
- c. Behovet for forhåndsvarsling om sannsynlig oppdrag kan variere på de forskjellige losstasjoner. Losenes behov for slik forhåndsvarsling kan være individuelt. Rutiner for forhåndsvarsling etableres i samråd med losene.
- d. Varsling av returlosing eller påfølgende oppdrag eller mulige oppdrag av slik art skal så vidt mulig skje senest ved tilvisning av fast oppdrag, og under alle omstendigheter så tidlig at losen får anledning til nødvendige forberedelser.
- e. Losene må til enhver tid ha anledning til å holde seg orientert om trafikksituasjonen ved å ringe losformidlingstjenesten. Dette er nødvendig pga. losenes spesielle arbeidssituasjon. Losformidlerne skal aktivt sørge for at den informasjon som gis eller blir etterspurt er så oppdatert som mulig.

 <b>KYSTVERKET</b>	<b>Kapittel 7</b> <b>INSTRUKSER OG BESTEMMELSER</b>  <b>7.4 Instruks for losformidlingstjenesten</b>	Dok. nr. MT-HB-7.4
		Rev. 0
		Dato: 09.01.2006
		Utgitt av: Sentral Los/VTS
		Side 3 av 3

### *6. Prioritering av oppdrag*

Som hovedregel skal los tildeles etter følgende prioritering; Til/fra havn, cruise fartøy, transitt-/kystlosing. Ved losmangel skal oppdrag som er forårsaket av rene militære bestemmelser nedprioriteres. Forøvrig må fartøy som overholder bestillingsfristen for losing prioriteres. Innenfor disse grupper kan det være aktuelt å prioritere fartøyer som er en potensiell forurensningsfare.

### *7. Spesialoppdrag*

Jf. Kystdirektoratets instruks for gjennomføring av uvanlige losoppdrag av 20. desember 1984.

### *8. Kjentmann*

I spesielle tilfeller kan kjentmann i form av los uten sertifikat for området tildeles ihht. forskrifter om losveiledning under losmangel.

### *9. Fravik*

Eventuelle fravik fra denne instruks skal godkjennes av Kystdirektoratet.



## Water Tight Integrity

### Purpose

The purpose of this procedure is to ensure that water tight integrity is maintained when vessel is at sea.

ProcedureKey	Activity	Document
General	Doors, hatches and manholes which are included in the water tight integrity of the vessels shall be closed at all times when the vessel is at sea. Doors and hatches may be used for normal traffic, but shall be closed after use.	Stability Booklet
Marking of essential openings	<p>Essential openings (Doors, hatches and manholes) in the water tight integrity shall be painted yellow and be marked with signs; "Keep Closed at Sea".</p> <p>For vessels with DNV Class, these openings are identified on the document LIST OF SIGNBOARDS, Appendix to the Classification Certificates.</p> <p>Manhole covers in general to be closed irrespective if they are marked or not.</p> <p>For vessels with other Class; LR, BV and GL, the essential openings shall be identified by vessel in close cooperation with the Superintendent. This list shall be sent to Vessel Name Quality for inclusion in KISS</p>	List of Signboards
Exemptions for essential openings	<p>When such openings are required to be kept open at sea for purpose of repairs &amp; maintenance work in tanks, rooms etc. a Risk Assessment shall be performed. This Risk Assessment shall take into consideration fairway, traffic, weather conditions, position and number of openings.</p> <p>No more than two ballast tanks shall be open at the same time and none in front of the collision bulk head. The period to be minimized.</p> <p>While vessel is in inshore waters, in areas with dense traffic or under pilotage, no doors, hatches and manholes included in water tight integrity shall be left open.</p> <p>The engine room should not be left "unmanned" if any access to rudder trunk, duct keel or cargo holds passageway from the engine room is left open.</p>	Risk Assessment
Control of doors, hatches and manholes	When essential openings are left open by exemption, Officer of the Watch (OOW) shall record opening and closing of these doors, hatches and manholes in Deck Log Book.	Deck Log Book