

REPORT

Sjø 2012/08



REPORT ON INVESTIGATION OF MARINE ACCIDENT, LANGELAND LDJB3, FOUNDER IN THE KOSTERFJORD, SWEDEN 31 JULY 2009

This report has been translated into English and published by the Accident Investigation Board Norway (AIBN) to facilitate access by international readers. As accurate as the translation might be, the original Norwegian text takes precedence as the report of reference.

AIBN has compiled this report for the sole purpose of improving safety at sea. The object of a safety investigation is to clarify the sequence of events and root cause factors, study matters of significance for the prevention of maritime accidents and improvement of safety at sea, and to publish a report with eventually safety recommendations. The Board shall not apportion any blame or liability. Use of this report for any other purpose than for improvements of the safety at sea should be avoided.

CONTENTS

SUMMARY	4
1. FACTUAL INFORMATION	6
1.1 Vessel and accident details.....	6
1.2 The course of events.....	7
1.3 Weather and sea conditions during the voyage.....	10
1.4 Rescue action.....	12
1.5 Shipowners and fleet	14
1.6 Crew	15
1.7 The vessel.....	16
1.8 Hatch covers and excavator.....	17
1.9 Loading port and cargo	19
1.10 Relevant regulations.....	21
1.11 The shipowners' management system	27
1.12 Official and classification society approval and supervision.....	33
1.13 Underwater investigations into the wreck by ROV and AUV.....	35
1.14 Examining the vessel's stability and strength	39
1.15 Examining the practice on battening down hatches.....	47
1.16 Implemented measures	49
2. ANALYSIS	49
2.1 Introduction.....	49
2.2 Examining the course of events when the vessel sank.....	50
2.3 Considering the list – possible causes and consequences	55
2.4 Assessing trim and stability	61
2.5 Assessing watertight integrity	64
2.6 Considering practice in relation to battening down hatches	69
3. CONCLUSIONS.....	71
3.1 What happened when the vessel sank	71
3.2 List and possible water in cargo hold.....	71
3.3 Trim and stability	72
3.4 Watertight integrity	73
3.5 Practice in relation to battening down hatches.....	73
4. SAFETY RECOMMENDATIONS	74
Safety recommendation SEA no. 2012/0x	74
Safety recommendation SEA no. 2012/0y	74
Safety recommendation SEA no. 2012/0z	75
Safety recommendation SEA no. 2012/0æ	75
ANNEXES	76

NOTIFICATION OF THE ACCIDENT

On Friday 31 July 2009, at 08.41, the Accident Investigation Board Norway (AIBN) received a report from the Maritime Directorate concerning the Norwegian-registered cargo ship Langeland LDJB3. The vessel was missing, presumed lost, in the Kosterfjord in Sweden.

The Langeland had loaded stone at Karlshamn, Sweden, on 29 July, and was en route to Rockwool A/S, Moss to discharge it. There was a crew of six on board, four from Russia and two from the Ukraine. The MRCC (Maritime Rescue and Co-ordination Centre) Gothenburg had already initiated a search at that time with all available units. The weather was bad, which made searching the area difficult.

The AIBN's accident inspector on duty instigated procedures for following up the accident immediately. Sweden, Russia and the Ukraine were contacted as parties involved, and invited to cooperate on investigating the accident.

A meeting in Stockholm on 16-18 September 2009 with representatives of AIBN, the Swedish accident investigation board (SHK) and the Ukrainian maritime authorities decided a joint investigation should be set up, with Norway as lead state and Sweden and the Ukraine as states involved. It also decided that the investigation was to be conducted in accordance with Section 18 of the Norwegian Maritime Act and IMO's guidelines for investigation of accidents at sea.



Figure 1: The Langeland sank on 31 July 2009, south in the Kosterfjord.

SUMMARY

The Langeland sailed from Stjärnöcrossen in Karlshamn, Sweden, en route for Moss in the afternoon of 29 July 2009. The vessel had a crew of six and was carrying crushed stone. When the vessel left Karlshamn, the weather was fine, with a slight south-easterly wind, but bad weather was forecast during the voyage. By the time Langeland passed Skagen on the evening of 30 July, the wind had increased from a moderate to a fresh gale, and was still increasing.

Early in the morning of 31 July, the captain called the shipowner twice, reporting that the Langeland was listing 10-15° to port and they were pumping water from the hold. He also reported that they intended to go into the Kosterfjorden to seek shelter. The wind had increased to a strong gale, with a significant wave height of 5.5 m. There was nothing in the calls to indicate the situation on board was dramatic.

The Langeland's last definite AIS position was recorded at 05.21. The first signals from the vessel's emergency beacon were recorded at 05.46, and a search and rescue operation was initiated. None of the six crew members on board were found. The vessel was subsequently located at a depth of 100 m, approx. 160 m north of its last AIS position.

The investigations indicate that the vessel gradually took on water between the hatch coaming and hatch covers due to the hatches not being secured. The weather which the vessel encountered had been forecast, and the crew had had enough time to prepare the vessel. There is nothing to indicate the crew did not know how to secure the hatches correctly; but there was damage to the hatch coaming aft which the AIBN believes may have occurred before the vessel was lost, and may have contributed to making it impossible to get all the cleats on.

The list reported ahead of the loss was probably due to the load having shifted, which in turn may have been due to the vessel having been exposed to synchronous rolling. The AIBN also considered other matters which may have contributed to the list, including the cargo absorbing water, steel structures collapsing and the outer skin cracking. These matters may have influenced the loss, but probably did not cause it, either individually or collectively.

New trim and stability calculations were prepared, and the results of these, as well as other documentation, indicated the Langeland's transverse stability was good despite her listing, and this was not a decisive factor in the loss.

It can be established with a great degree of certainty that the Langeland did not capsize, but went down bow first. As the cargo shifted to port and across the hold, and with water coming in through leaking hatches and damaged hatch coamings, there was not enough reserve buoyancy left aforeships when the stern lifted and the bow went into the heavy sea.

The Langeland's stability calculations from when the vessel was new (1971) were inaccurate and ignored the longitudinal trim. Nor were any inclining- or displacement tests conducted when the vessel was converted which would have led to the trim and stability calculations being revised. That meant there were two design errors in the Langeland which were not discovered until it was lost. The reserve buoyancy was basically too low, and the forward cargo hold bulkhead was positioned too far forward as far as the intentions of the Construction Regulations were concerned. Experience indicates it could not be loaded in the forward part of the cargo hold without the forward trim becoming too great. That led to large

areas of the cargo hold forward being unused and open to cargo and water which could shift further forward than assumed when the vessel was approved. Together, these two design errors meant the Langeland's survivability was significantly reduced, especially in following high seas, in which the wave length prior to the loss was believed to have been approximately the length of the ship.

To ensure stability calculations are conducted correctly and include sufficient trim estimates so that similar design errors do not occur in other cargo vessels, the AIBN believes one should consider implementing a requirement that all cargo vessels registered with the NOR and NIS which have not conducted calculations using approved software, must prepare new complete trim and stability documentation. The AIBN will submit a safety recommendation to the Maritime Directorate in this regard.

The Ship Construction Regulations of 1969 which were applied in the design and construction of the Langeland, include particular Norwegian rules on maximum forward trim / minimum bow height when calculating theoretical, homogenously loaded full load conditions. These rules were continued in the Ship Construction Regulations of 1979, but when the Norwegian International Shipping Register (NIS) was set up in 1987, the rules were internationalised and the specific Norwegian provisions left out. The above provisions were consequently omitted from the Ship Construction Regulations of 1987 and 1992, resulting in ships that were built or will be built after 1987 having been or being built with their forward cargo hold bulkhead positioned too far forward. The AIBN believes action should be taken to prevent this, and the Accident Investigation Board therefore takes the view that the rules on maximum forward trim / minimum bow height should be reintroduced. The AIBN will submit a safety recommendation to the Maritime Directorate in this regard.

The investigation into the loss of the Langeland found that the vessel's lightship data has changed significantly since the vessel was built in 1971. An age allowance which is unknown and uncorrected for will generally represent some uncertainty in terms of both trim and stability. This means that the vessel's stability documentation, which is used to make operational assessments, will be unreliable. The AIBN believes regular inclining tests or displacement readings should be used to discover any age allowance and establish correct lightship data for cargo vessels, as is already required for certain passenger ships and fishing vessels. The AIBN will submit a safety recommendation to the Maritime Directorate in this regard.

In the light of the investigation, the AIBN has reason to believe that failing to batten down hatches properly is not an isolated incident, but cannot establish how widespread this practice is. The Accident Investigation Board therefore advises the Maritime Directorate to making aware hazards related to ignoring to batten down hatches.

1. FACTUAL INFORMATION

1.1 Vessel and accident details

Details of the vessel

Name	:	Langeland
Call sign / IMO no.	:	LDJB3/7113727
Shipowner / ISM resp.	:	Myklebusthaug Management A/S
Classified by	:	Bureau Veritas
Flag state	:	Norway / NIS
Type / class	:	1 + HULL + MACH General cargo ship Unrestricted navigation Ice + AUT-UMS
Yard and year built	:	Georg Eide – Høylandsbygd 1971
Construction material	:	Steel
LOA	:	69.98 m
Breadth	:	13.21 m
Depth moulded	:	6.45 m
Draught	:	5.40 m international / 5.625 m national
Deadweight tonnage	:	2490
Gross tonnage	:	1591
Engine(s)	:	Alpha Diesel 14V23HU, 1750 Bhp
Bow thrusters	:	Brunvoll 150 hp
Propeller CPP	:	1 x Alpha cp bronze diam. 2180 mm
Service speed	:	Approx. 10.5 knots



Figure 2: The Langeland entering port at Fønnes. (Photo: Myklebusthaug)

Details of the accident

Date and time	:	31 July 2009 05.22
Accident location	:	Kosterfjord, Sweden
Persons on board	:	6
Lives lost	:	6
Losses	:	Total loss(sunk)

1.2 The course of events

There were no survivors when the Langeland was lost on 31 July 2009: so the Accident Investigation Board has relied on interviews with others involved, AIS data and other technical data to describe what happened as correctly as possible.

The Langeland had a cargo of crushed stone (diabase 55-130) loaded at Stjärnöcrossen in Karlshamn, 14.55 Swedish time on Wednesday 29 July 2009. The ship took on a total of 2353 t of diabase. Loading was carried out in accordance with the ship's loading plan, except that the crew had asked to have the last 10 t of the cargo in the aft cargo hold to optimise trim when sailing. The vessel sailed for Rockwool A/S at Moss, Norway at 15.20. The weather at the time of departure was good, with a weak south-easterly wind, later increasing to breeze, and maximum significant wave height of 0.5 m. A gale forecast was sent out via Navtex on 29 July at 04.30 UTC, forecasting that a strong low pressure centred between Scotland and Iceland was on its way in via the North Sea and the Skagerrak. Reports with updated weather reports arrived at regular intervals the next day, and on 30 July, at 16.30 there were also forecasts of winds up to storm force 25 m/s later that evening and through to the morning of 31 July for the area the vessel was sailing into.

The vessel's route took it round the southern coast of Sweden, up through Drogden off Copenhagen and northwards into the Øresund. The Langeland passed Hålsingborg at around 07.00 on the morning of the 30th of July; by the same evening, when passing Skagen, the wind had increased to south-west moderate to fresh gale with waves around 4 m. Sometime after 22.00, the captain called the pilot station at Horten and the ships agent in Moss to report a new ETA, as he estimated the bad weather would delay their arrival by around two hours.



Figure 3: Map roughly showing the Langeland's route from Karlshamn to Koster.
Map: The Coastal Administration

AIS data shows the Langeland maintained a steady northerly course through the night, until, on the morning of 31 July, at 03.54, in a position west of Väderöarna, the ship changed course sharply to starboard. The speed at this time was approx. 8 knots. The wind had now increased to a strong gale, and the wave height continued to increase. After 5-6 minutes, the Langeland turned to port again, and continued on a course towards Kosterfjord.

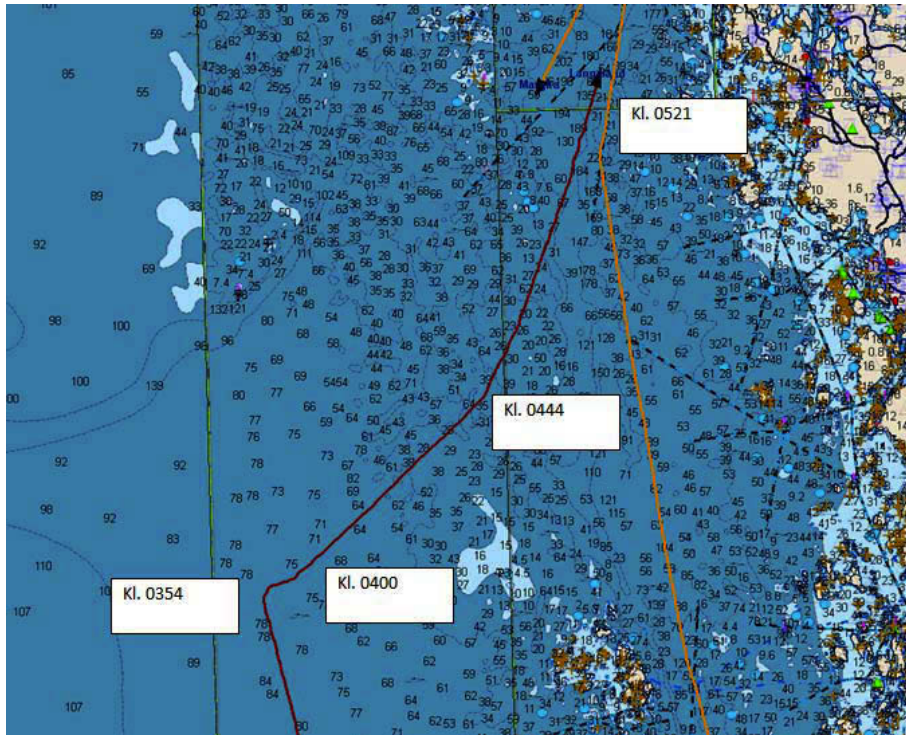

Figure 4: The last part of vessel's route

At 04.19, the captain called the shipowner and said the Langeland was listing 10-15° to port. The owners representative believed he also remember that the captain had said they were pumping water out of the cargo hold. The captain also said he intended to go into the Kosterfjord to take shelter, so they could take better stock of the situation. The owner asked the captain to contact Strömstad VTS to tell them what his intentions were in entering the Kosterfjord. Lastly, it was agreed the owner would call back in an hour to get an update on the situation. The owner told AIBN there was nothing in the call that indicated the captain was stressed or in an emergency.

Somewhat later, at 04.39, Gothenburg VTS replied a call from the Langeland. They informed Strömstad VTS was no longer operational and no further reporting were required. The captain confirmed he understood, and told them he was thinking of going up the Kosterfjord to find shelter 'to make something correct'. Gothenburg VTS confirmed that was OK. The captain seemed calm during this call also.

When the shipowner called back at 05.18, the Langeland had still not reached the lee of the Koster islands. The captain said the weather was now poor, and that they were still listing. He estimated they would be in shelter in half an hour, and it was agreed they would call again then. There was nothing in this call to indicate the situation on board was dramatic.

The coastal tanker Margita was sailing southwards in the Kosterfjord at this time. The officer on duty on board the Margita observed the Langeland at a distance of 3-4 nautical miles with its deck lights on. As the two vessels approached one another, the deck lights were switched off. The Langeland and Margita passed one another at approx. 05.20 one nautical mile apart. The officer on the Margita could not see anything abnormal on board the Langeland, but pointed out later that it would have been difficult to notice a list under the weather conditions at the time, which he described as stormy from the south with a wave height of 10-12 m and some showers.

The Langeland's last definitely observed AIS position was at 05.21.40. Its course was then 018° and its speed 8.6 knots.

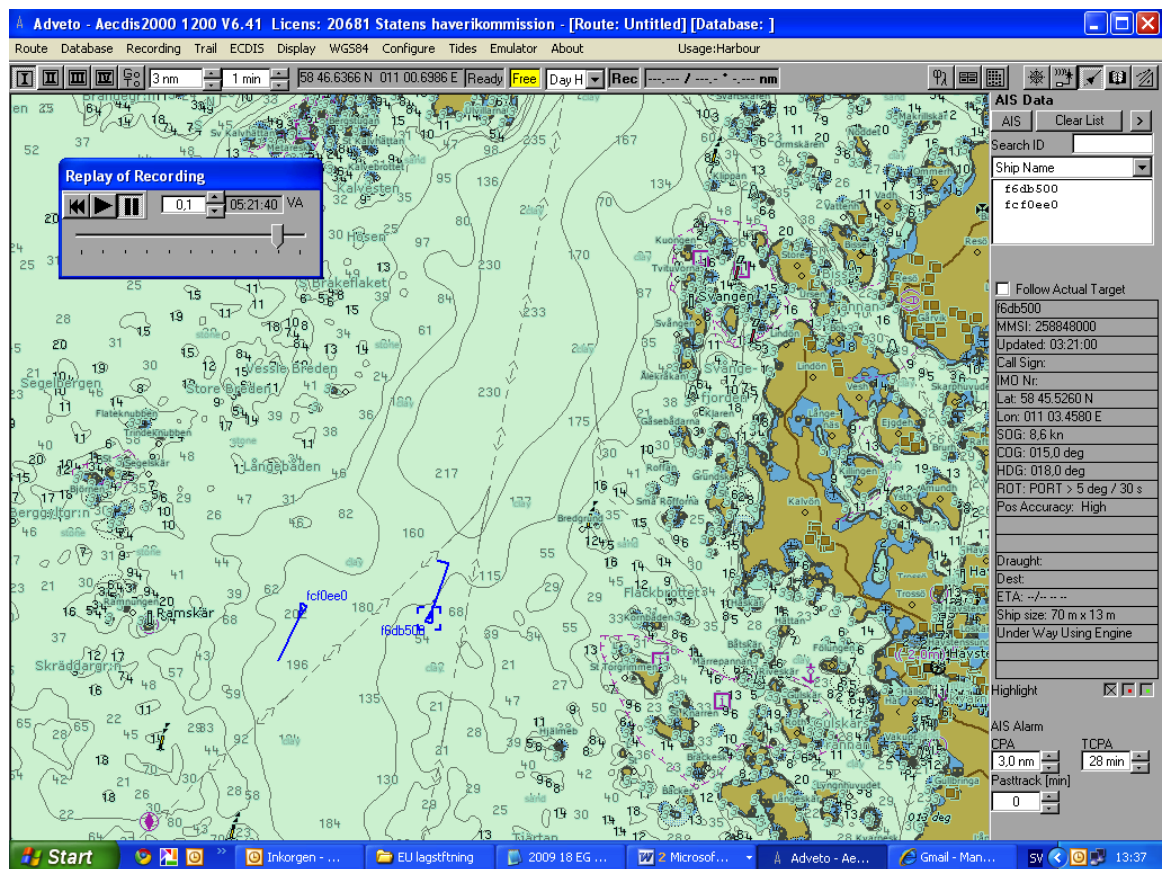

Figure 5: Map showing the Langeland sailing northwards and the Margita southwards

When the owner called the Langeland again at around 05.40, he could not reach the ship.

The first signals from the Langeland's EPIRB were recorded by satellites in the COSPAS / SARSAT system at 05.46. The first message from this system to MRCC Gothenburg was recorded at 06.00, and the procedures for emergency reports via EPIRB were implemented.

The search for the wreck found various bits of wreckage and rescue equipment. None of the crew members were found. The wreck was located on 2 August, at a depth of about 100 m, app. 160 m north of the last AIS position.

1.3 Weather and sea conditions during the voyage

1.3.1 Weather reports

There were regular weather reports from Stockholm Radio on VHF in addition to the gale warnings. There were also regular Navtex reports via Gisløvhammer and Grimeton covering the areas of the voyage, see annexes. As well as the regular weather reports, there were also additional gale warnings.

Navtex reports had already forecast at 04.30 UTC on 29 July that a large low pressure centred somewhere between Scotland and Iceland was on its way in over the North Sea and Skagerrak. The first gale forecast sent via Navtex was at 11.30 UTC on July 29.

The reports with updated weather reports were issued regularly over the following day, and on 30 July, at 16.30, there was also a forecast of winds up to storm force 25 m/s later that evening and through to the morning of 31 July for the area where the Langeland was lost.

The bad weather that hit the Langeland on the last part of its voyage was duly forecast, so the crew on board should have been well aware of it.

1.3.2 Weather observed

Based on a report from the Swedish Meteorological and Hydrological Institute (SMHI) (see annexes), the wind and weather conditions changed as follows:

The voyage started under calm weather conditions, with a weak high pressure ridge covering southern Scandinavia. In the Hanö bay, a weak south-easterly wind was blowing, which increased slowly to 5-8 m/s; the significant wave height was around 0.5 m.

The Langeland sailed via Drogdenrenna northwards and passed Hälsingborg at around 07.00 on the morning of 30 July. By then, the wind had risen to south-east 6-10 m/s due to a cold front with ample thunder showers that was rapidly moving north-east past Kattegat. Wave heights in the Øresund were still moderate, between 0.5 and 1.0 m, but increasing towards noon.

A low pressure area developed off the south coast of Norway during the afternoon of 30 July and moved northwards along the west coast of Norway for the next 12-18 hours. That meant the Langeland had a wind from the south-southeast of gale strength 12 – 16 m/s. The south-east sea off the west coast of Sweden increased to 2-3 m wave height. Later that evening, the Langeland left the area in the lee of North Jutland / Skagen, and was then hit by rapidly building sea from the south-west, with the significant wave height increasing rapidly to approx. 4 m with a maximum wave height of 5-6 m.

During the night of 31 July, between midnight and 05.00, as the Langeland sailed northwards along the Swedish coast on the stretch from west of Lysekil to west of Väderöarna to Ramskär, the weather worsened considerably. Based on observations made on the Koster isles, the wind conditions were now southwest gale 15 – 19 m/s. Wind gusts up to storm force, a good 25 m/s, were also observed. As the Langeland approached the area where the vessel was lost, a south-westerly wind 17-21 m/s was observed with gusts up to 26 m/s.

The wave direction in the area was constant from the southwest, with a significant wave height of 4.5/5.5 m and maximum wave height of 7-8 m. The wave height at Väderöarna continued increasing until 09.00, with a significant wave height of around 6 m and maximum waves of 9.3 m; both wind and sea then abated over the day (Fig. 6).

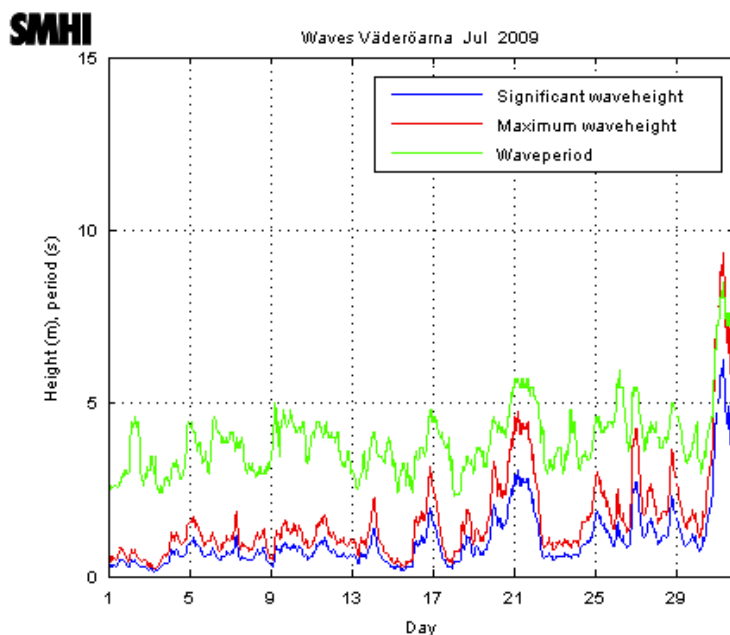

Figure 6: Wave conditions from test buoy at Väderöarna July 2009. Source: SMHI

The weather's effect on the vessel

As the Langeland sailed north along the coast, the waves were hitting it somewhat aft of the port beam. This changed when the vessel headed for the Kosterfjord. The voyage towards the Kosterfjord was over shallower areas, which may be assumed to have altered the wave situation. The wave direction and length in relation to the Langeland's courses are shown in Fig. 7 below. These matters are described in detail in Annexe C and analysed in Ch. 2.4 and 2.5.

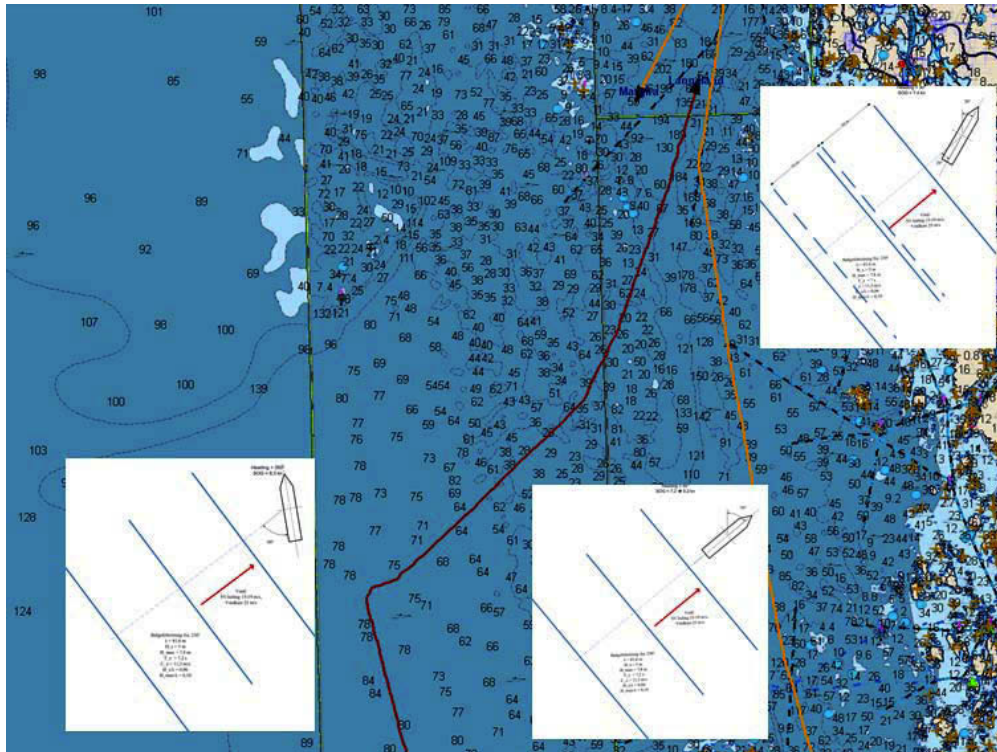

Figure 7: Wave length scaled to vessel size and direction combined over last part of voyage.

1.3.3 Other observations

The chemical tanker Margita met the Langeland in the Kosterfjord at 05.20. The Margita appears as the southbound vessel directly west of the Langeland in Fig. 5. The officer on duty on board the Margita estimated the wave height at 10-12 m at that time.

The Accident Investigation Board has been in touch with local fishermen operating in the Kosterfjord area. They generally believe that the southern part of the Kosterfjord is characterised by difficult sea conditions under strong southerly and south-westerly winds. The east side of the fjord in particular is characterised by rough seas. Records of losses from the 1700s through to the post-war years show there were many losses in the southern Kosterfjord.

The sea temperature off the west coast of Sweden was 17-18° at the time of the loss.

1.4 Rescue action

The Swedish Maritime Administration is responsible for both sea and air rescue services in Sweden. The search and rescue operation after the Langeland foundered was headed by the MRCC (Marine Rescue Co-ordination Centre) Gothenburg. Vessels from the Swedish Sea Rescue Association (SSRA), the Coastguard (KBV) and Norwegian Society for Sea Rescue (RS) were also involved in the rescue operation, plus helicopters from both the Swedish and Norwegian rescue services and an aircraft from the Swedish coastguard.

At 05.46 on 31 August, a polar orbit satellite in the COSPAS / SARSAT system received a message from the Langeland's free-float distress beacon (EPIRB). When processed, the signals from the free-float beacon indicated it was in the Kosterfjord area¹. Reports of this observation were received at the Swedish rescue centre MRCC at 06.00. The rescue centre was getting reports from the Norwegian rescue centre at Bodø of the same observation at the same time. The rescue centres agreed that the Gothenburg rescue centre would coordinate from then on.

The MRCC now classified the incident as an emergency. At 06.08, the MRCC raised the alarm with the Swedish Sea Rescue Association, which sent one of its vessels out from Strömstad to see if there really was an emergency in the Kosterfjord. The MRCC kept trying to call the Langeland on VHF channel 16, but got no reply. The rescue centre then searched for the vessel on its AIS systems, but the last observation they had was in Hanö bay on the evening of 29 July. They received updated AIS information from KBV and the main rescue centre at Bodø later.

At 06.39, the MRCC informed the Gothenburg rescue helicopter, which took off at 07.06 and reached the search area at 07.31.

At 06.57, the SSRA vessel found two lifejackets belonging to the Langeland, and saw one of the Langeland's life rafts a few minutes later.



Figure 8: One of the Langeland's rafts. (Photo: SSRA)

From 07.08 and over the morning, the MRCC began mobilising more vessel resources from the SSRA, the Swedish coastguard and Norwegian Society for Sea Rescue. A systematic search for survivors in the sea was conducted during the morning and early afternoon. A number of objects from the wreck were found, including both life rafts and a number of lifejackets; but the rescue teams found no signs of the crew. Weather conditions on day one of the search were challenging, with a south-westerly wind up to 25 m/s and waves up to over 9 m. The ship and helicopter search was called off on the evening of 31 July. During the rescue

¹ The positional accuracy requirement is to within 5 nm. There will be two possible positions when first received.

operation, the shipowner and the Swedish and Norwegian rescue services communicated well.

The air search resumed the next day, but did not find anything else. The rescue vessels and local fishermen searched for the Langeland using echo sounder, and located the vessel on the seabed.



Figure 9: Prevailing weather conditions during the rescue operation

1.5 Shipowners and fleet

The Langeland was owned by Mikkal Myklebusthaug Rederi and operated by Myklebusthaug Management AS (referred to as ‘the shipowner’ or ‘owner’) from Fønnes outside Bergen. This shipping company operates container ships, dry bulk, offshore/supply vessels and barges.

The shipping company is a fully-integrated management company responsible for:

- Chartering and operations
- Crewing
- Insurance
- Administration
- Accounts

At present, the shipping company operates six container ships, one general cargo vessel, three self-loading mini-bulk vessels, two offshore vessels and three barges. It employs 210 people in total, 12 of them onshore. The vessels under Myklebusthaug Management are owned mainly by companies in the Myklebusthaug group.

Myklebusthaug Management AS is ISM, ISO 9002, ISO 14000 and ISPS certified.

The shipping company has been helpful and facilitated the Accident Investigation Board’s safety investigation following the accident.

1.6 Crew

The Langeland had a crew of six at the time of the accident: the captain, first officer, chief engineer and three able seamen. Work in the on-deck department on board was conventionally organised in a two-watch system at sea, with the captain and an able seaman holding watches from 08.00-14.00 and 20.00-02.00. The first officer and an able seaman had watches from 14.00-20.00 and 02.00-08.00.

When in port, watches were organised as the captain decided. The entire crew helped with loading and discharging as required.

The ship was classified to sail with a periodically unmanned engine room (E0), which means the chief engineer had day watches and kept E0 watches when the engine room was unmanned.

The crew on board were recruited via Eastern European manning agencies. The return rate for the shipping company's crew is high, and many of the crew members had sailed on board the company's vessels many times.

New crew go through a familiarisation programme when they first arrive. When it comes to training in closing and securing the vessel's cargo hatches, the procedures in the shipping company's safety management system refer to the manufacturers' operators' manuals. Training on board is mainly practical on-the-job training, with inexperienced crew members learning from those who are experienced.

The *captain* (32) was from Russia, with a class 1 deck officer certificate. He had been working for the company and as captain on board the Langeland since 21 April 2009. He had a total of 10 years' experience as first officer and captain on container ships and vessels similar to the Langeland. The captain is responsible for the safety of the crew, cargo and vessel.

The *first officer* (38), from Russia, held a class 2 deck officer certificate. He had worked for the company since 18 September 2007. He had nine years of experience as first officer on vessels equivalent to the Langeland and slightly more than one year of experience as first officer on container ships. The first officer was responsible for managing the work in the deck department, and reported to the captain. That includes being responsible for stability, loading and unloading operations.

The *chief engineer* (35) from Russia held a class 1 engineer officer's certificate. He had worked for the company since 6 December 2007. He had eight years of experience as an engineer, the last two and a half years as chief engineer.

The *able seaman / welder* (46) from the Ukraine had worked for the company since 22 July 2005. He had a long record as an able seaman on ro-ro / container ships before joining the company.

The *able seaman / repairman* (39) from Russia had worked for the company since 17 June 2009. He had a long record as able seaman on dry bulk and refrigerated ships.

The *able seaman / cook* (44) from the Ukraine had worked for the company since 23 May 2008. He had a long history of experience as cook on vessels of different kinds.

1.7 The vessel

1.7.1 The vessel

The vessel was built as a shelter deck dry bulk ship by Georg Eides Sønner A/S, Høylandsbygd, and delivered as the MS Langeland to K/S A/S Langeland & Co. (Anders Stokka), Haugesund in 1971. The vessel had an overall length of 69.98 m, sailed under Norwegian flag and was classified by DNV.

The Langeland was sold to I/S Janneland (Harald Jacobsen Shipping A/S), Oslo in 1974 and changed its name to Janneland. It was sold again in 1978, now to K/S A/S Langeland II (Anders Stokka), 5400 Stord and was renamed the Langeland.

Mikkal Myklebusthaug bought the ship in 1982. The Langeland had been classified by DNV since it was built. It was transferred to Bureau Veritas in 1986, and remained there until it was lost.

The vessel was transferred to the Danish International Shipping Register (DIS) in February 1990, and was now owned by Langeland ApS, c/o Advokat Dedichen, Copenhagen, with Mikkal Myklebusthaug as director of the company. The Langeland changed its name to Langefoss.

The vessel returned to the Norwegian Ordinary Ship Register (NOR) under the name Langeland in November 1990. It was now owned by Mikkal Myklebusthaug Rederi, 5153 Fønnes. In 1992, the vessel moved to the Norwegian International Ship Register (NIS), where it remained until it was lost.

1.7.2 Rebuilding

The Langeland was modified and rebuildt several times after it was first delivered. Of the major conversions, we can mention:

In 1977, a traverse was fitted, with a Brøyt excavator on the shelter deck. The Brøyt machine was subsequently replaced by a Caterpillar 330. The side and bottom fittings of wood, main deck hatches and part of the main deck in the sides of the cargo hold between frames 25 and 90 were removed before 1982.

The vessel's cargo hold was modified considerably in 1982, including fitting a double transverse bulkhead at a distance of approx. 500 mm. This bulkhead was fitted near frame 58. The bulkhead was not watertight, and ended approx. 300 mm below the shelter deck. Another transverse bulkhead was also fitted at frame 90 between the tank top and main deck. This bulkhead was not watertight either. A skewed transverse bulkhead was also fitted between the tank top and former main deck in front of the engine room. This bulkhead was not watertight, and extended from frame 25 up to frame 28 by the tank top.

In 1984, the vessel was 'boxed' by fitting steel dunnage to the frames on either side of the cargo hold between the skewed bulkhead aft and the transverse bulkhead at frame 90. Vertically, the dunnage ran from the tank top and remaining strings from the former main deck. The cavity between the dunnage and the head of the vessel was not accessible for inspection. The fore and aft loading booms were also removed in the 1980s.

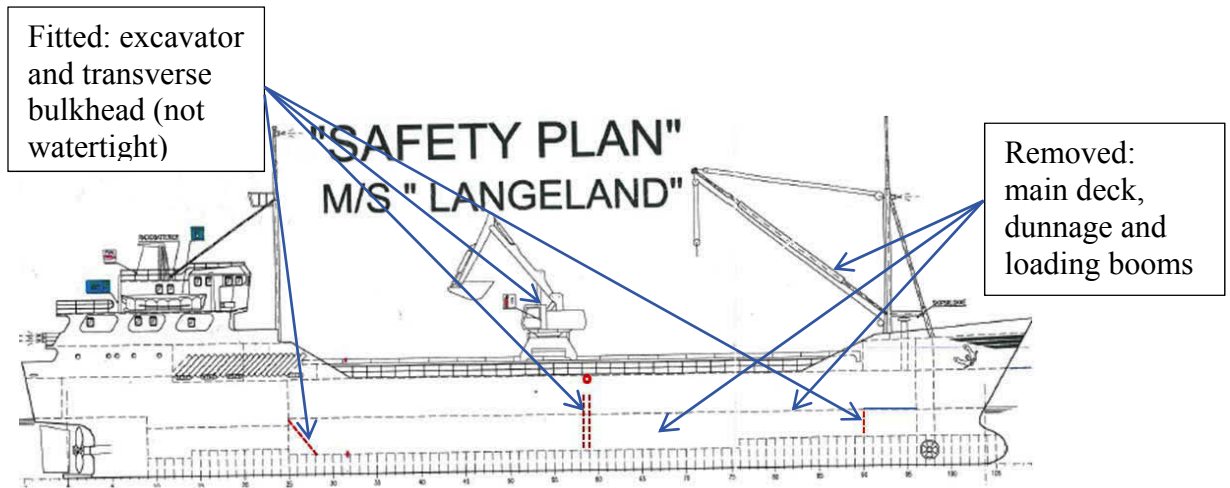

Figure 10: Modifications to the Langeland

1.8 Hatch covers and excavator

1.8.1 Hatch covers

The Langeland had MacGregor type single-pull hatch covers. MacGregor single-pull covers consist of a series of steel covers linked together by chains. The Langeland originally had 19 hatch covers, 16 of the same size. The three foremost hatch covers were formerly welded together to form a pontoon, and were independent of the others. These were rarely opened, but could be lifted manually using a line attached to the forward mast. The other hatch covers were operated hydraulically, and ran longitudinally on wheels or rollers attached to the hatches and running in tracks along the hatch coamings. On the Langeland, in the stowed position, the hatch covers were stored in the hatch hold under the bridge.

To make the hatch covers weather-tight when they were on, the wheels or rollers were lowered into tracks in the hatch coamings. These tracks contain the hatch jacks which ensure the wheels or rollers are lowered into the coaming to bring the hatch covers into contact with the hatch coaming. Gaskets between the hatch coaming and hatch covers ensure a good weather-tight fit.

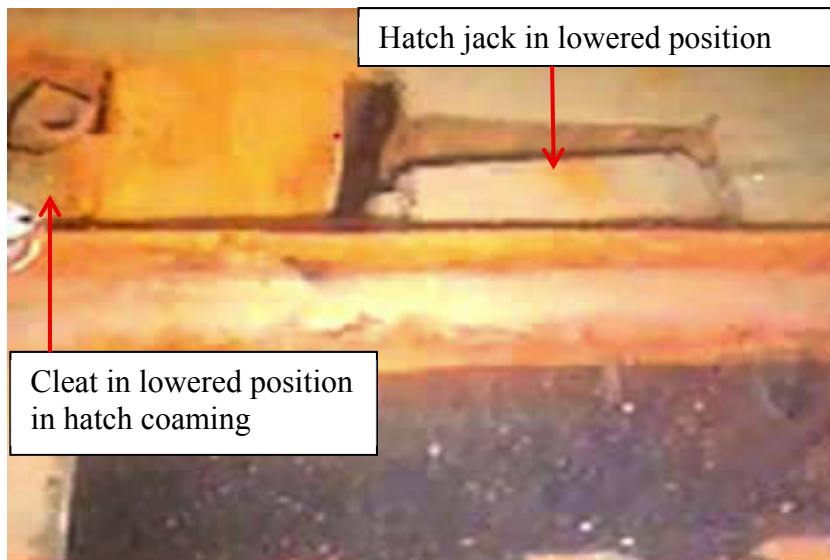

Figure 11: One of the hatch jacks in the lowered position and a cleat in the lowered position. (Photo: KBV)

The hatch covers are attached to the hatch coaming by cleats. Cleats hang down the frames in the hatch coaming, and run up through openings in the coaming to be slid into place in two welded-on lips / brackets on the hatch cover. The head of the cleats is bent over. At the lower end of the cleats, there are strong rubber gaskets to help ensure good contact and flexibility. When the hatch covers are pressed against the coaming by means of the cleats so that the gaskets are compressed, good contact is ensured between the hatch coaming and cover.

The Langeland had two cleats in the hatch coaming on either side of each cover. The hatch cleats are designed to keep the hatch covers in contact with the coaming and tolerate tensile stresses. If the cleats are stretched too heavily, they will be torn off, or alternatively torn out of their mounting in the coaming or bracket on the hatch cover, depending to some extent on how worn they are. The hatch coamings, hatch covers, gaskets and cleats are inspected and maintained at regular intervals to ensure they are watertight as intended. The hatches must always be on and secured when sailing.

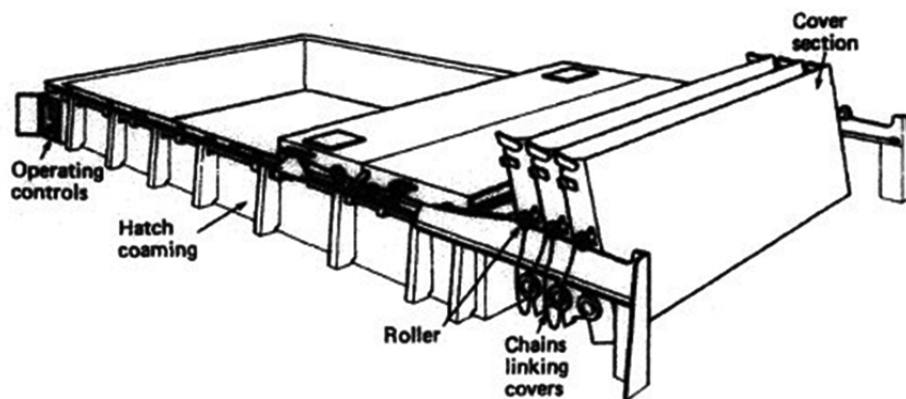

Figure 12: MacGregor single pull hatches.

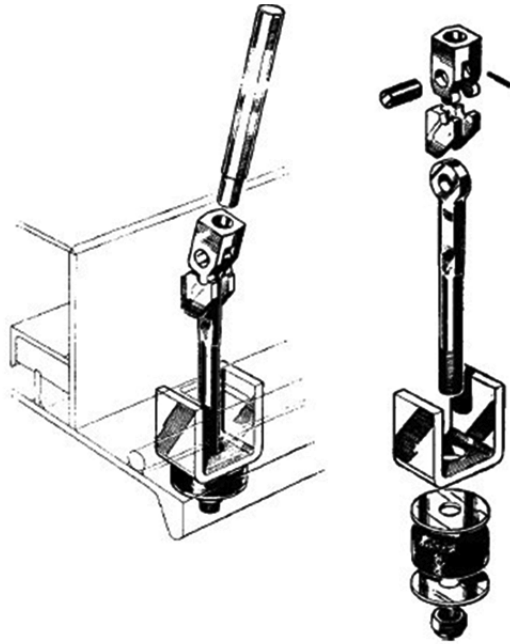

Figure 13: Cleats for battering down hatch covers.

1.8.2 Excavator

The vessel had a Caterpillar 330 excavator, capacity approx. 300 metric tonnes an hour. Together, the excavator and traverse weighed about 87 t. The excavator was normally parked forward of the bridge and attached to special attachments on the hatch coamings.



Figure 14: (Left) Excavator parked in normal position. (Right) One of two excavator attachments (starboard)

1.9 Loading port and cargo

1.9.1 Loading port

The Langeland loaded stone at Stårnökrossen² in Karlshamn on 29 July 2009. The vessel arrived at the plant at 09.15. The ship was loaded at the plant via a conveyor belt which can be rotated in three directions. This belt has a capacity of 550-600 t/h and can weigh accurately to within 1% (Source: NCC Stårnökrossen).

² Stårnökrossen is part of NCC and produces 350-400,000 t of the stone product diabase a year. Of the total production 170-180 shipments leave by sea annually.



Figure 15: Conveyor belt loading at Stjärnökrossen.

1.9.2 Loading operations

The Langeland had been loading stone at Stjärnökrossen regularly since the 1970s, and had loaded 10 times a year on average in recent years. Loading was carried out in accordance with the ship's loading plan. For the voyage that ended with it being lost, the load was distributed as shown in the diagram below, except that the ship asked to have the last 10 t in the aft cargo hold to get the best possible trim.

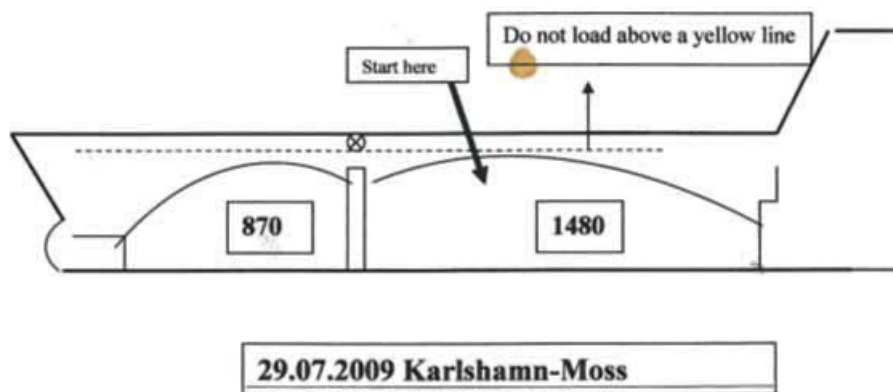

Figure 16: Copy of the loading plan for 29 July 2009

The operator loading the vessel was told not to load over the lines painted inside the hatch coamings. Loading started amidships along the vessel at 10.05, aft of the transverse bulkhead which divided the hold in two. Loading was done by moving the belt from side to side and forward and back to get the load as flat and even as possible. This part of the loading operation was supervised and directed by one of the vessel's crew on deck. While loading the last 2-300 t, crew members were also down on the quay watching the foot marks, to load the vessel even keel. Loading was completed at 14.55, and the vessel left Stjärnö at 15.20. Once loading was complete, the vessel's crew used the excavator to level out the top of the load, also ensuring the load was well distributed in each side of the vessel.

Speaking with staff at the loading facility at Stjärnö, it appears the vessel normally closed its hatches on the way out from the port. They were not sure whether that was the case when it sailed on 29 July. It also emerged from conversations that the Langeland normally arrived and sailed with the excavator parked forwards.

1.9.3 Cargo

The vessel loaded 2353 t of diabase 55-130 in all (crushed rock approx. 5-13 cm in size), see Fig. 17. The cargo was bound for Rockwool AS in Moss, to be used for making insulation. The cargo density was 1.6 t/m³ and had an estimated angle of repose of around 45°, see Fig. 18.



Figure 17: Diabase 55-130. Photo Swedish accident investigation board



Figure 18: The cargo's angle of repose, approx. 45°.

1.10 **Relevant regulations**

Building and operating a vessel like the Langeland is governed by several laws and regulations. Regulations relevant to this accident are as follows:

1.10.1 Act of 16 February 2007 no. 09 relating to ship safety and security (the Ship Safety and Security Act)

The Ship Safety and Security Act applies to all Norwegian ships, and aims to protect life, health, the environment and property by defining the rules of good ship safety and management, including preventing ships causing pollution, ensuring a good working environment and secure working conditions on board and good, prompt supervision.

Shipping companies have a duty generally to ensure their ships are operated in accordance with rules laid down in or under this act, including that the master and others working on board comply with the rules.

1.10.2 Regulations of 23 September 1969 relating to construction of cargo vessels (Construction regulations)

The Construction Regulations that applied to the Langeland were from 1969, effective as of 1 January 1970.

For trim and stability purposes, the requirements of the regulations included that, based on lightship data obtained from inclining tests, GZ curves, statements of meta-centre height, trim, etc. be prepared for the load conditions below:

1. Ship in ballasted condition with full equipment and stock and bunkers for a normal voyage.
2. Ship in ballasted condition, as in 1, but with 10% stock and bunkers.
3. Ship loaded to summer load line (international and / or domestic) with cargo distributed evenly in all spaces including hatches, with full equipment and stock and bunkers for normal voyage. Ballast water tanks to be drained.
4. Ship loaded as in 3, but with 10% stock and bunkers.
5. If there was to be cargo on deck, sailing and arrival conditions for this were to be worked out.

Each load condition must show that the following minimum stability requirements were met:

- The area below the curve which shows the righting lever (GZ curve) must be at least 0.055 m radians calculated up to an angle of heel of 30° and at least 0.09 m radians up to 40°, or to the filling angle if this is less than 40°. In addition, the area below the curve between 30° and 40°, possibly the filling angle, must be not less than 0.03 m radians.
- The righting lever (GZ) must be at least 0.20 m at an angle of heel of 30° or more.
- The angle of heel at which the righting lever (GZ) is at maximum value should be more than 30° and must never be less than 25°.
- The initial metacentric height (GM) must be at least 0.15 m
- Filling angle: the angle of heel at which water can penetrate via openings in the hull, superstructure and deckhouse which are not closed by weather-tight closures in accordance with the load line convention.

Section 6.3 of the Construction Regulations of 1969 read as follows:

When cargo ships of 50 t and over are built, bought in from abroad or undergo alterations which may affect their stability to a significant degree, they must undergo inclining tests to establish their lightship centre of gravity. Based on this centre of gravity, hydrostatic data and form stability data for the ship, GZ curves must be produced, stating the metacentric height, trim, etc. to handle the ship's stability characteristics.

In other words, updated load conditions had to be drawn up for approval if the lightship centre of gravity (and displacement) had changed according to the inclining tests.

As was stated above, under the Section 6.3 of the Construction Regulations of 1969 it is not merely the transverse stability that have to be calculated, but also the longitudinal trim. In terms of what was relevant to the Langeland, what Section 6.3 required to be prepared and submitted to the Maritime Directorate for approval was as follows:

- 6.3.1 *Report of inclining tests and their results.*
- 6.3.2 *Cross curves and similar, hydrostatic curves or similar and volumes and centres of gravity for holds and tanks.*
- 6.3.3 *Curves showing the righting lever (GZ) for load conditions as follows:*
 - 6.3.3.1 *Ship in ballasted condition, with full equipment, stock and bunkers for a normal voyage.*
 - 6.3.3.2 *Ship in ballasted condition, as in section 6.3.3.1, but with 10% stock and bunkers.*
 - 6.3.3.3 *Ship loaded to summer load line (international and / or domestic) in accordance with current load line rules, with load distributed evenly in all holds, including hatches, with full equipment and stock and bunkers for a normal voyage.*
 - 6.3.3.4 *Ship loaded as in section 6.3.3.3, but with 10% stock and bunkers.*
- 6.3.5 *Load conditions as stated in section 6.3.3.3 must be calculated with ballast water tanks drained.*
- 6.3.6 *Load conditions as stated in sections 6.3.3.3 and 6.3.3.4 will not normally give the ship a forward trim. If the ship's bow height is greater than the regulation bow height, forward trim can only be accepted at a value equal to 30% of the excess bow height, but not in any case more than 0.5% of the ship's length.*
- 6.3.7 *If ballast water is needed to meet stability and / or trim requirements in loaded condition as stated in section 3.3.4 or in any other load condition to be approved, separate stability calculations with GZ curves must be drawn up subject to the ballast water used. The calculations must show clearly how much ballast water is used and where it is located.*
- 6.3.8 *The load is under all load conditions assumed to be homogenous and evenly distributed unless this is incompatible with the ship's purpose.*

That is to say, the regulations were designed with a view to giving built-in safety in vessels in three essential areas which are not expressed directly in the wording of the regulations:

- That the regulations did not allow having ballast water in fully-loaded sailing conditions meant vessels had to be designed with built-in safety, so that the available deadweight in excess of necessities such as fuel oil, fresh water, provisions, etc. could be used entirely as load. Otherwise, any ballast water required might risk being sacrificed in return for more load in certain cases. The load would have a higher centre of gravity than the ballast water, and would not therefore meet the stability requirements.
- That it should also be a requirement that the load should be homogeneously and evenly distributed in the spaces, including hatches, i.e. load with one and the same specific weight in all volume available for load, means that the centre of gravity of the load cannot normally in fact be higher than under the full load conditions prescribed. A heavier load than the ones used under those conditions would necessarily occupy less space, and hence would have a lower centre of gravity. A lighter load would occupy the space available and have the same centre of gravity as used under these conditions, but not all the deadweight would be used.
- The requirements of the regulations on maximum forward trim and minimum bow height in relation to no ballast water in the sailing condition and a limited amount of ballast water in the arrival condition in which the bunkers used could be made up for by ballast water, would give a built-in harmony between buoyancy and the weight of the load, so sufficient reserve buoyancy would be assured aforeships as well as good manoeuvrability.

The regulations did not lay down any requirements on regular inclining tests or displacement measurements as is the case with certain passenger ships and fishing vessels today. Passenger ships which are convention ships must be displacement tested at least every five years to discover any changes to their displacement and longitudinal centre of gravity. Fishing vessels with an overall length of over 15 m must have inclining tests conducted at least every ten years.

For hulls (design and strength, etc.), the regulations required classified ships to comply with the rules of the inspecting bodies concerned and the rules and regulations laid down by the Maritime Directorate.

1.10.3 Regulations of 26 November 1979 on construction of ships, regulations of 15 June 1987 on construction of passenger ships, cargo ships and barges and regulations of 15 September 1992 on construction of passenger ships, cargo ships and barges

The Construction Regulations of 1979 upheld the provision on maximum forward trim / minimum bow height, cf. section 6.3.6 above; but this provision was omitted in the Construction Regulations of 1987 and 1992. The provision was removed in 1987 due to the internationalisation of the rules in connection with setting up the Norwegian International Ship Register (NIS). The provision on maximum forward trim / minimum bow height was one of a number of provisions specific to Norway which were removed at the time.

These provisions did not require inclining tests or displacement measurements.

1.10.4 Regulation of 15 June 1987 no. 507 on safety measures, etc. on passenger ships, cargo ships and barges

The regulations on safety measures cover hatches, closures and stability, etc.

All hatches, closures, etc. must comply with current load line rules at any time, and cargo hold hatches must be properly closed and battened down when ships are not in port.

Stability documentation and resources must be kept on board. In general operations, care must be taken to ensure that stability information is taken into account and current conditions for approving them, including weather-tight and watertight closures and load distribution. Ships must be loaded so they are sufficiently stable under all conditions and the ship's master, having considered the ship's manoeuvrability, etc. can make the preparations required to achieve a reasonable trim throughout the voyage under the loading conditions on board the ship.

1.10.5 Regulations of 14 March 2008 no. 306 relating to safety management systems on Norwegian ships and mobile installations

Safety management system requirements are governed by "FOR 2008-03-14 no. 306: Rules on safety management systems on Norwegian ships and mobile installations", referred to hereinafter as the ISM regulations. These regulations apply inter alia to Norwegian cargo ships of a gross tonnage of 500 and over. The rules are based on the international standard for safety management for operating ships and preventing pollution, the International Safety Management Code or ISM code. This is intended to maintain safety at sea, prevent personal injury and loss of human life, avoid harming the environment, the marine environment in particular, and damage to property. Shipping companies are required to ensure that safe practices are followed when operating ships, and a safe working environment, to introduce protection against all identified risks and to continuously improve the skills of crew involved in operating ships. Safety management systems must ensure that mandatory rules are followed and current rules, guidelines and standards are observed.

Safety management systems are structured, documented systems which enable the company's staff to implement its safety and environmental protection policy effectively. These systems must ensure that mandatory rules and regulations are complied with and that current rules, guidelines and standards recommended by the organisation (International Maritime Organization – IMO), the authorities, classification societies and other shipping industry organisations are observed.

Section 2 of the regulations requires all shipowners to have safety management systems as part of their organisation and on individual ships in accordance with the ISM code.

All companies must design, implement and maintain security management systems covering the operating requirements below:

- A safety and environmental protection policy
- Instructions and procedures to ensure safe operation and protect the environment in accordance with current international law and their flag state legislation
- Defined levels of authority and lines of communication between and amongst personnel onshore and on board
- Procedures for reporting accidents and non-conformities
- Procedures for preparing for and responding to emergencies
- Internal audit and management review procedures

The responsibility for verifying, reviewing and monitoring safety management systems under the ISM code is divided amongst a number of parties.

Flag states and others involved in certifying ships on their behalf are responsible for controlling, verifying and certifying safety management systems. They must verify that the company and management on board are operating in accordance with approved safety management systems.

Shipowners are responsible for conducting internal safety audits to verify that their business is in line with safety management systems in terms of safety and preventing pollution.

Shipowners must review safety management systems regularly to see how effective they are, and review those systems in accordance with the company's defined procedures (management reviews).

Masters are responsible for reviewing safety management systems on board and reporting any defects to shore-based management (captain's reviews).

1.10.6 Regulations of 1 January 2005 no. 8 relating to working environment, health and safety for workers on board ships

These regulations are intended to ensure that work and time off on board is set up and organised in such a way as to preserve the employees' safety and physical and mental health. Shipowners, masters and others working on board must ensure and assist in ensuring that the regulations are applied in accordance with the Ship Safety and Security Act. Shipowners must ensure that requirements arising out of the regulations are met via the safety management system. All employees must be trained as required, and steps must be taken to ensure employees are given and understand information on safety risks.

1.10.7 Regulations of 15 June 1987 no. 506 concerning survey for the issue of certificates to passenger ships, cargo ships and barges and other inspections, etc.

Cargo ships with a gross tonnage of 500 and over used on longer voyages than small coastal voyages must have safety certificates for equipment, design and radio,

or alternatively cargo ship safety certificates. Certificates are issued by the Maritime Directorate or approved classification societies.

Certificates are issued following inspection for periods of up to five years, with an interim inspection. Inspections are to be conducted in accordance with the Ship Safety and Security Act with associated regulations, and must include verifying that the hull, machinery, equipment, safety equipment, fire safety provisions, fire fighting systems, navigation aids, stability calculations, crewing, etc. comply with current regulations.

1.11 The shipowners' management system

1.11.1 System manual

The system manual incorporates safety, environmental, quality and shipping company standards. The manual includes all relevant procedures common to the shipping company and vessels, including emergency procedures, checklists and diagrams. Operations plans on board, maintenance, non-conformity reporting and management, internal audits and management reviews are other relevant procedures covered by the system manual.

Concerning operation plans on board, the manual states that procedures and operating instructions are drawn up to ensure the safety of the crew, ship and cargo in accordance with national and international requirements. Checklists are used to help ensure that procedures in special operational phases are covered.

Special operations on board are defined as operations in which errors do not become apparent until they lead to hazardous situations on board or an accident has happened. These include such things as navigating safely, maintenance, bunkering, stability and handling and securing cargo.

Critical operations on board are defined as operations in which any errors could immediately cause accidents or hazardous situations. Procedures and operating instructions for critical operations are available: these include things such as emergencies, serious list, water ingress, grounding, collision, fire / explosion, evacuation, reduced visibility, heavy weather and pollution. There is also a plan for drills on board providing regular training in a range of emergencies.

Battening down hatches was not defined as a critical operation, but working instructions were found on operating and securing hatches.

1.11.2 Maintenance system

The shipping company has implemented a system for planning and conducting maintenance (Planned Maintenance System – PMS). This maintenance system assumes the ship is put in dock twice every five years, and other maintenance is based on these intervals and the authorities' and manufacturers' requirements in terms of maintenance frequencies for the ship and equipment. The ship issues monthly general status reports as well as reports for bunkers and lubricating oil consumption and machinery running hours. Any non-conformity must also be reported. Classification status and status of certificates and inspections must be reported every three months and when a new captain takes over.

The shipping company must conduct at least one technical inspection a year, and a detailed checklist has been produced for this purpose. These inspections are held to ensure that ships and equipment are maintained in accordance with established procedures.

1.11.3 Non-conformity system

The shipping company's non-conformity system is divided into three levels: what is to be reported, when it is to be reported and following up non-conformance reports.

Accidents must be reported. Accidents are defined as incidents or series of incidents which have unwanted consequences for life, the environment or the ship and equipment. Failure to comply with internal or external requirements, such as port state control requirements, must be reported. Incidents which might have led to accidents but did not have any consequences must also be reported, so-called near misses.

Non-conformity reports must include description of incidents, in sufficient detail to understand exactly what happened, why and what the consequences were. They must also include proposals for measures and say who should be responsible for follow-up. Pictures and illustrations should also be included if possible.

Accidents must be reported immediately, to the person nominated or shipping company's representative on duty; and any other non-conformities which need to be dealt with immediately for the ship to continue its voyage must be reported promptly. Near-misses must be reported in connection with handover reports when the captain comes off duty.

The shipping company will evaluate non-conformity reports after reviewing them and take corrective action as required. Evaluating non-conformity reports may lead to corrective action, experience being communicated to others at the shipping company concerned, procedures and instructions being added to or new procedures drawn up. The shipping company must keep the ship's management informed of status and measures taken. Once corrective measures have been taken, the captain will report to the person(s) appointed to close the non-conformity procedure.

1.11.4 Internal audits

Internal audits must be conducted annually, and are designed to ensure that the shipping company and fleet practice is in line with the shipping company's procedures and instructions and other mandatory requirements.

Audit implementation plans must be drawn up to indicate what areas the annual audit will cover. Plans must cover a five-year period, and all areas must be covered at some point during this time. In addition to audit implementation plans, a list must be drawn up of data for external auditors, internal audits, technical inspections and the captain's and the management's reviews. These plans must be distributed both to ships and the administration on shore.

The shipping company is responsible for ensuring that internal audits are conducted in accordance with relevant requirements, by competent personnel regardless of the area being audited. Audit reports must be written in accordance with shipping

company procedures and must include details of the area audited, who was audited, and a summary of the audit, including observations and non-conformities.

The last internal audit on board the Langeland was conducted at the quayside at Gudvangen on 14 July 2009, just two weeks before the accident. This audit was conducted by the shipping company's QA manager, and the crew on board at the time of the audit was the same as when the ship was lost. Five non-conformities were found in the course of the audit, as well as seven observations (minor non-conformities). One of the non-conformities was about maintaining hatches and associated equipment, which concludes, "The hatches need to be repaired by welding weekly to keep gaskets tight and prevent water getting in. Hatch coamings, hatches and wheels badly worn." As this non-conformity was not reported until shortly before the accident occurred, no report was made to the shipping company on whether any maintenance or repairs were conducted as a result of this. The damage to the aft hatch coaming which was noted during the ROV inspection after the loss was not observed during this audit.

1.11.5 Captain's reviews

Captain's reviews must be held annually, and must include reviewing the shipping company's safety management manuals, inspections and audits, non-conformity reports, safety meetings, drills and training and how well the safety management system works, HSE matters, etc.

The last captain's review was held on 22 May 2008.

1.11.6 Management reviews

The safety management system must be reviewed annually as part of the management review. The agenda for the management reviews must be as follows:

- Review last management review to verify that observations have been implemented effectively
- Customer feedback, both favourable and adverse
- Findings of external audits, customer inspections and port state control
- Internal audit findings
- Recommendations by classification societies and other official inspections
- Accident, incident and near-miss analyses
- Proposed improvements
- Goal attainment
- Effectiveness and relevance in terms of safety management system
- Any other tasks / areas that will need focus in the time ahead

- Further training required
- Changes required to the safety management system or shipping company organisation generally

Should anything be found in the course of a management review which requires particular attention, this must be documented and classified and recorded in the non-conformity system if necessary.

The last management review before the ship was lost was held on 23 October 2008.

1.11.7 Technical inspections

Technical inspections must be conducted on board each ship every year by technical inspectors from the shipping company. The areas to be inspected are ship management and administration, hull, cargo handling equipment, ship's equipment, crew equipment, main engines, other mechanical systems, and usual systems on board. All areas inspected are rated on a scale from 1 to 5. There is also a field for comments for each checkpoint.

- Unacceptable conditions requiring immediate action. The safety of the crew, cargo or ship is at risk.
- Conditions fall short of requirements laid down by the shipping company and must be improved. The shipping company must conduct a new inspection by a set date.
- Conditions fall short of requirements laid down by shipping company and need to be improved.
- Equipment is 100% acceptable, well maintained, no further action required.
- Equipment is new or as new.

If any area inspected scores two points or less, that will result in a note against the ship's management if they can be held liable for the conditions or are aware of them but have not improved or rectified matters. Any and all findings which are not found to be satisfactory, or score three points or less, must be commented on in a separate report, together with a plan for suitable measures to be taken.

The most relevant areas as far as the accident is concerned, which are inspected in the course of the technical inspection, are the hull and cargo handling equipment. The last technical inspection on board prior to the accident was carried out on 15 November 2008, when the Langeland was along the quay at Fonnes to replace main engine blocks, etc. All areas inspected were found to be 100% acceptable, well maintained and no improvements required, except two minor observations which cannot be considered as having anything to do with the accident. Nor was anything noted in connection with wear and tear or the need to weld hatches, as the internal audit report pointed out just six months later.

1.11.8 Checklists

Pre-departure checklists must ensure amongst other things that meteorological and navigation notifications have been received on Navtex. All weather doors, hatches and other openings must be closed and secured. Cranes and cargo equipment must be parked and secured in position.

As there was little water under the keel, and because the Langeland depended on leaving port on an even keel, the ship was usually trimmed using the excavator. That was then standing forwards, and was not secured in the parking position forward of the superstructure until they had sailed from the quay and were clear of the shallow areas.

1.11.9 Vessel's manual

The vessel's manual includes procedures which are relevant to operations on board, both procedures which are common to all vessels and ship-specific procedures. Some relevant procedures are the captain's 'standing orders', handling and securing cargo, operating hatch covers and excavator, stability, sailing procedures, drills and exercises and emergency procedures covering such things as listing badly, shifting loads and water penetration.

1.11.10 Captain's standing orders

The captain's standing orders state that the officer on duty must ensure that the cargo is adequately secured and that the vessel is ready for sea in all respects. The shipping company's pre-departure checklist must be used. While sailing at sea, the captain must be called if the officer on duty is in any doubt as to the traffic situation, if visibility is reduced, or if a hazardous situation could arise. The vessel's speed must be adjusted to the circumstances in response to reduced visibility, weather conditions and traffic.

1.11.11 Keeping watches

Bridge watches were kept on a 6-6 system on board the Langeland. The management system states that the captain must stand the 8-2 watch and the first officer 2-8, but they had changed on board the Langeland, so the captain stood the 2-8 and the first officer the 8-2. They each had an able seaman on duty with them. The Langeland was classified E0 and its engine room was unmanned at times.

It was the captain who was on duty at the time the vessel was lost, and it was he who called the shipping company and contacted Gothenburg.

1.11.12 Sailing plans

To ensure voyages are made securely, a sailing plan must be drawn up. This must be done before sailing, and must include details of the voyage itself and the weather and weather reports. There is no reason to believe the crew was not aware of the bad weather that had been forecast.

1.11.13 Handling and securing cargo

It is the captain's responsibility to draw up a stowage plan taking account of the ship's stability. The captain or his deputy must supervise the loading to identify and

report any damage, non-conformities or accidents and verify that loading is being carried out in accordance with the load schedule. The cargo must be secured as laid down in the cargo securing manual.

All damage, non-conformities and irregularities must be documented and reported.

Investigations show there is damage to the back of the hatch coaming that may have occurred in the course of loading or unloading. This damage was not reported to the shipping company.

1.11.14 Hatch cover operations

Hatch covers must be operated in accordance with the manufacturers' user manual. The covers must not be operated unless there is less than 2° list and the trim must not exceed 2.5°. Hatch covers must be operated by two or more persons.

Opening the hatches and securing the hatch covers in the open position is described in detail. On closing and securing cargo holds and hatch covers, see cargo securing manual and manufacturers' user manual.

The Accident Investigation Board has received conflicting information as to whether the hatches were secured in accordance with established procedures or not.

1.11.15 Stability

Before each departure, the captain must conduct stability calculations, either computer assisted or manually. With ships less than 100 m which sail regularly with the same kind of cargo, such as stone or sand, and have good stability margins, the captain can decide whether to conduct stability calculations or not. The Langeland did not have a load computer on board.

The shipping company must be informed should the ship's stability change dramatically at any time while at sea. The captain alerted the shipping company on the morning of the day the vessel was lost.

1.11.16 Safety drills

Safety drills on board, combined with regular training, should ensure that the crew are as prepared as possible to deal with any emergencies which may arise. A schedule of drills must be drawn up to be held over the year: this schedule must include lifeboat drills, fire drills, man overboard, personal injury, pollution, communication and other exercises involving water penetration, the ship listing and bad weather, for example. Drills must be carried out under a range of operating and weather conditions. Each drill must end with a meeting at which that drill is reviewed and evaluated and any changes or new proposals put forward.

1.11.17 Emergency procedures

The crew must be alerted and told what is happening if an emergency arises, and the necessary action taken. The nearest coastguards must be alerted, along with the shipping company, insurers and agents. Assistance must be requested.

No emergency reports were sent out from the Langeland until the free-floating EPIRB was activated automatically, but the shipping company and Gothenburg VTS were warned of the problems, although the situation was not described as critical.

1.11.18 List, cargo shifting

If a ship starts listing badly or the cargo shifts, an alarm should be activated and the captain called onto the bridge if he is not already there. If cargo has shifted as a result of yawing or rolling, the ship should change course and adjust speed to reduce the effects of the sea. The crew must be on standby and lifeboats and rescue rafts made ready. The crew should as far as possible look into why cargo may have shifted and what has shifted, why it shifted, any damage, the likelihood of further shifting and suggest action to reduce the consequences. All resources available, such as ballast pumps, hydraulics, etc. must be made ready. The relevant authorities must be alerted if the ship appears to be at risk; the shipping company must be alerted and kept updated on the situation on a regular basis in every case. Steps should be taken to secure the shifted cargo if this can be done without risk to life. Calculations must be made to see if ballast can be used to reduce the list. Only if the captain is satisfied that the voyage can continue without risk can the sailing continue. The shipping company and captain will together consider whether to seek an emergency port or shelter for the weather to offload cargo for safety reasons. All activities must be logged.

The captain had informed the shipping company that the ship was listing and was on its way up the Kosterfjord to seek shelter.

1.11.19 Water penetration

If water gets in, the alarm must be sounded and the captain summoned. Watertight doors must be closed if the ship is fitted with them. The crew must be on standby. The ship must be manoeuvred so as to keep the crew safe and reduce the amount of water getting in. Soundings must be taken to establish how much water is getting in and how fast. Lifesaving gear must be made ready. The relevant authorities must be informed, depending on how serious the situation is, and the shipping company kept up to date. Soundings will be used to assess how the water getting in is affecting the ship's stability. Consideration must be given to whether there is sufficient pump capacity on board to bilge out the water and keep the incoming water under control. All pump capacity available on board must be used, both fixed and mobile pumps. Any materials available on board (dunnage, mattresses, etc.) must be used to stop or reduce water getting in if possible. All activities must be logged.

The shipping company believes the captain said they were pumping water out of the cargo hold.

1.12 Official and classification society approval and supervision

The Langeland was registered in the Norwegian International Register (NIS). For cargo ships registered with NIS, the Norwegian authorities have delegated official inspections, including auditing safety management systems, to approved classification societies. To ensure this arrangement works as intended, the Maritime Directorate audits the classification societies. For details of the arrangements, see the contracts between the Norwegian Ministry of Trade and Industry (NHD) and the respective classification societies concerned.

It was Bureau Veritas (BV) that carried out the inspections for issuing safety certificates and ISM audits for issuing safety management certificates for the Langeland. The Langeland changed its classification from Det norske Veritas (DNV) to BV in 1987 and had been classified with BV ever since.

The last inspection on board was conducted during the period between 9 and 16 December 2008, and was an annual inspection of the hull, machinery, alarms and automation, load line, construction, safety equipment, radio and equipment for preventing pollution.

It was noted during this inspection that some areas of the hull and in the tanks were corroded. Steel was replaced in the areas concerned during the inspection, and the improvements were considered satisfactory. Nothing was said about the hatch coamings, hatch covers or associated equipment. The water level alarm in the cargo hold was also tested and found to be in order. Sea trials were also held following installation of a new engine block and crankshaft after the main engine was damaged in September 2008. BV had no comments in this regard.

It was also BV that conducted the ISM audits on board the Langeland. BV used this supervisory role to verify and approve the shipping company's security management system, both in terms of its onshore organisation and on board the vessels. It is their job to verify that the company and management on board are working in accordance with the safety management system as approved. If the safety management system is approved, a certificate of approval (Document of Compliance – DoC) is issued to the shipping company as evidence that it meets the requirements of the code. A safety management certificate (SMC) will also be issued for the ship, confirming that the company and management on board are operating the ship in accordance with the approved safety management system. The shipping company has set up a safety management system in accordance with ISM rules, comprising a system manual, a ship's manual and a shipping company manual. The shipping company manual is not relevant to the company's vessels. In addition to the objective of complying with the rules, guidelines and standards recommended by the IMO, the authorities, the classification societies and other organisations in the shipping business, the shipping company's safety management system is also produced to meet the requirements of ISO 9001-2000 and ISO 14001-2004.

The safety management certificate for the Langeland was issued by BV in Rotterdam on 19 July 2007, following a renewal audit conducted on 18 May 2007. One non-conformity notice was issued in connection with the audit. The certificate was issued effective until 23 May 2012, provided the system was verified periodically between two and three years from when the certificate was issued.

The certificate of approval was issued in Rotterdam on 18 September 2006, effective until 27 August 2011. Certificates of approval must be verified annually, and the last audit prior to the accident was on 4 November 2008. No non-conformities were observed in connection with this audit.

The Maritime Directorate held an unannounced NIS inspection on board the Langeland at Halden on 9 January 2008. Two orders were issued and six observations were made: none of these matters is seen as having anything to do with the loss.

The last Port State Control (PSC) was held at Køge, Denmark on 4 February 2009. No orders were issued in connection with this control or the two previous port state controls.

1.13 Underwater investigations into the wreck by ROV and AUV

1.13.1 ROV investigations

The wreck of the Langeland was first located by local fishing boats on 1 August. On 2 August, the weather conditions, including on the seabed, were good enough to allow an ROV to be sent down. The Swedish Coastguard at KBV 307 was able to confirm that the wreck was the Langeland, but no investigations were conducted, other than to establish the name on the wreck.

KBV 307 sent their ROV down again on 9 August: representatives of the shipping company and Accident Investigation Board were also present on this occasion. The wreck was quickly located by sonar. Two smaller echoes were also identified south of the wreck, which local fishermen said were not on the bottom before the accident occurred. These objects were thought to be the excavator, hatches and possibly cargo. There were not conducted any ROV-inspection of these objects.

Filming the wreck started at around 14.30. The vessel was lying on the bottom listing to port, partly buried by clay masses on the port side and on the foreship. The rudder was lying to port. ROV investigations showed that the cargo hatch covers were not in place.

Details of the hatch coamings were filmed, on the port side, as far as this was visible, on the starboard side and aft. Examining the film shows 18 cleats on the port side, six cleats aft and 34 on the starboard side. The ROV film also showed that two of the vessel's hatch covers were still in the cargo hold. These hatches were standing with one end down in the cargo hold and the other end resting up on the hatch coaming. The hatch covers were lying upside down. The ROV investigations did not show any more hatch covers, although the investigations conducted later showed two hatch covers which were partly embedded in the sediments in front of the vessel's bow.

The aft hatch coaming was visibly damaged: there was a sharp bend and a scar which, from the nature of the damage, is believed to have been made by a relatively sharp object with its force directed forwards. It may seem from the images as if this damage was of more recent date.

The ROV was also sent down into both the aft and forward holds, without any details emerging in the filming. What could be established was that there was little or no cargo left in these holds, however.

Working forwards from the stern, it was difficult to get an overview of the damage, as the foreship had driven itself partly into the clay bed. There was no sign of the forward mast, but parts of the traverse and rail to the working platform linked to the forward mast were visible. The traverse had broken away from the forward mast at the weld.

Few observations were made from the ship's sides, only parts of the port side that were visible above the clay were investigated; but there was nothing to indicate there had been a structural collapse in the hull, given that no damage was observed on the port side, and that the hatch coamings and deck plates were intact and not deformed.

A number of antennas had broken loose on the superstructure. The port lifeboat was hanging by its forward hook alone, and the bow was partly crushed. Aft on the poop deck, the door into the superstructure was open, this was hinged so it opened outwards. A refrigerator used for storing paint out on the poop was missing. Up on the boat deck, the lifebelt cases had disappeared. It was not possible to observe any damage apart from this. The starboard side of the superstructure was not filmed.

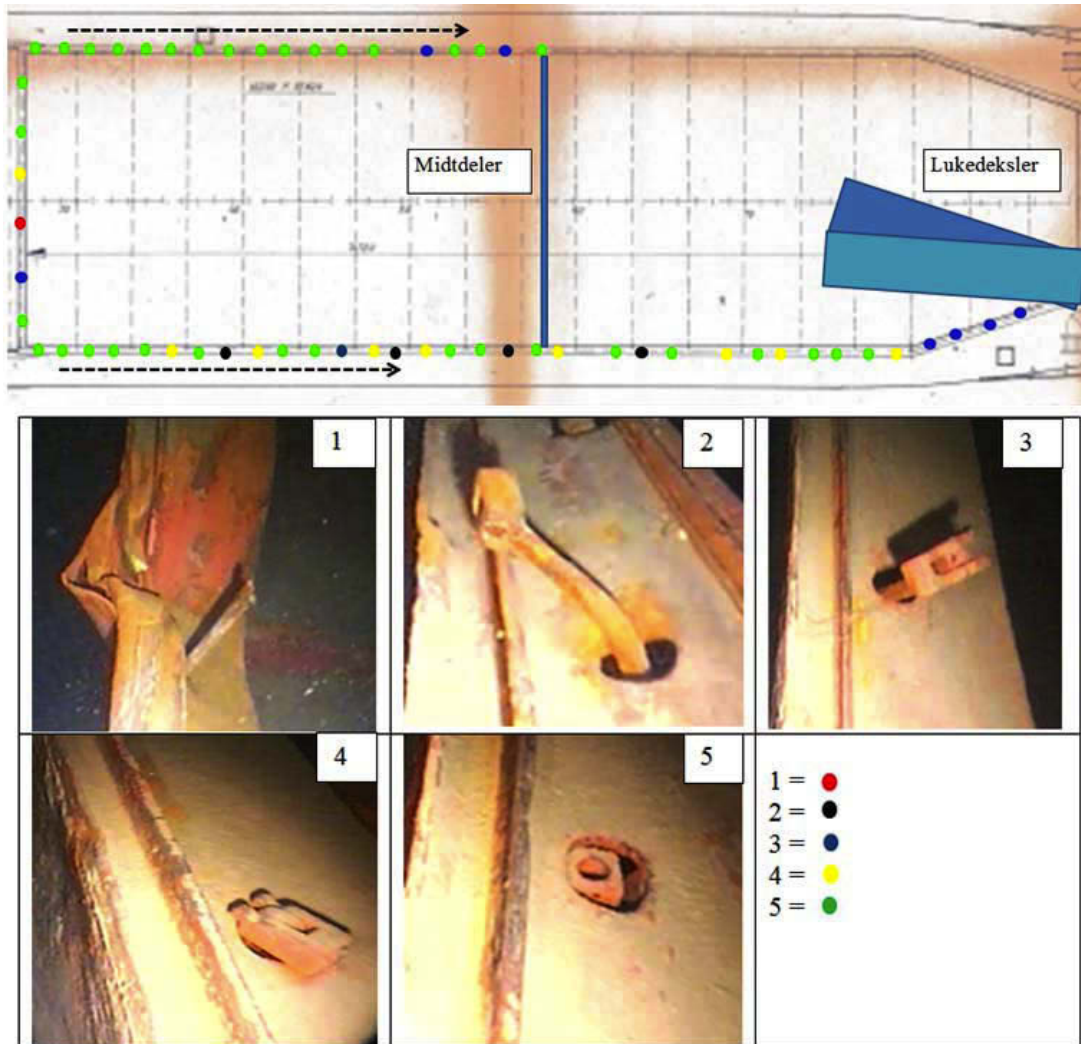

Figure 19: The sketch at the top shows the condition of the hatch cleats plotted against the background of the ROV images. Cleats shown in red are those that were broken (picture 1). Cleats shown in black are those standing over the hatch coaming (picture 2). Those shown in blue are those standing over the hatch coamings apparently undamaged (picture 3). Yellow cleats are apparently undamaged with their heads over the hatch coaming (picture 4). Green are apparently undamaged cleats lying down in the hatch coaming (picture 5). The dotted black line shows where the chain used by the excavator to move along the ship is broken.

1.13.2 AUV investigations

An underwater operation to make a map of the wreck and any bits of wreckage from the Langeland was conducted on 30 May 2011. This operation was conducted using the autonomous underwater vehicle (AUV) HUGIN HUS with sonar from the Norwegian Defence Research Establishment (FFI). The sonar used was a synthetic aperture sonar (SAS) HISAS 1030. Kongsberg Maritime's vessel the Simrad Echo was used as the mother ship. The Simrad Echo is equipped with multi-beam echo sounding EM710, which was used to establish a seabed map of the area. Representatives of AIBN and the Swedish Accident Investigation Board (SHK) were present, as well as operators from the FFI and Kongsberg Maritime.

The Hugin dive was planned to cover the area around the wreck, focusing particularly on the area south west of it. The reason for this was that if the

excavator or other equipment had fallen off before the vessel sank, that was the area it would be in as the Langeland was on a northerly course before it sank. Some crossed lines were included around the wreck to cover the vicinity particularly well.

Wind conditions were difficult on the day the operation was conducted, but the mapping was conducted once the wind had calmed down enough.

The wind conditions and conditions on the bottom around the wreck meant the picture quality was not ideal. A fault on the AUV was discovered during the dive, and so the images were poorer than expected. The images were still good enough for AIBN's purposes with the investigation, however.

The investigations showed that the Langeland is lying with its bows at around 75°. Some remains of the wreck were observed around the forward section of the ship which is believed to be individual cargo hatches and the traverse for the excavator. The seabed is clearly disturbed in a large area around the forward section of the ship, and the ship's bows are buried in the seabed.

At 317°, down the slope the wreck is lying on, there is a landslide approx. 180 m long.

It was also found that objects on the bottom slightly south of the wreck which had been thought to come from the Langeland were a natural rock formation which did not come from the wreck.

The pictures have since been examined and analysed by personnel of FFI, AIBN and the shipping company's representatives.

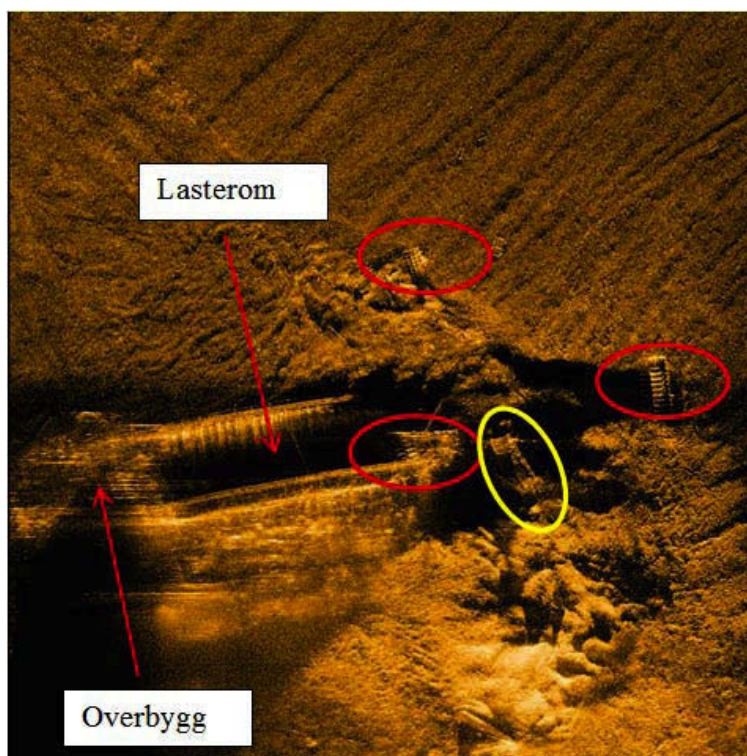

Fig. 20: Wreck on the bottom, with the bows at approx. 075°. Hatch covers marked by red rings, traverse by yellow ring. (Photo: FF)

1.14 Examining the vessel's stability and strength

1.14.1 Introduction

It was important for the investigation on how the Langeland was lost, to gain an overview of the position in terms of stability and the hull (construction, strength, etc.) at the time it was lost. Historical evidence in these areas was also required as the basis for producing new stability calculations.

The shipping company gave the Accident Investigation Board access to the stability calculations approved for the Langeland: these were from the 1970s, were mainly calculated manually, and the first series was highly simplified, in that only the transverse stability was calculated, and not its trim. The calculations did not therefore reflect the longitudinal centre of gravity. This meant that it soon became clear during the investigations that the Accident Investigation Board would have to have new stability calculations prepared to get as precise an overview of the stability conditions at the time of the accident as possible. There were no design drawings or any basis for the load conditions approved, including listing test results. This information was needed in the further investigation.

1.14.2 Obtaining documentation of stability and the hull

The Langeland was classified by Det norske Veritas from delivery as a new build and until 1986. The Norwegian Maritime Directorate had delegated official responsibility for approving the construction and strength of the hull and allocating freeboard and issuing load line certificates to DNV. Design drawings and dimensioned calculations and freeboard plan were key documents which DNV had had in its possession; but when the Accident Investigation Board started gathering evidence in 2009, it was more than 20 years since DNV had been involved with the vessel, and so the association had scrapped its documents for the vessel.

The Langeland was classified by Bureau Veritas in 1986, and classification with DNV was deleted soon afterwards at the shipping company's request. Classification at BV was made with 'approvals valid', and as far as the Accident Investigation Board has been able to find out, no basic documents were exchanged such as drawings or calculations from DNV to BV. BV submitted the class status report and the inspection record since 1986 to the Accident Investigation Board.

The Norwegian Maritime Directorate had very little documentation on file for the Langeland, and nothing from before 1990. The Directorate's general information on the vessel contained another file reference than the current one, but nothing about where the documents for this other reference were to be found. As neither the Directorate nor the Ships Registers had noted the official deletion date when the Langeland was flagged out to Denmark in 1990 and most of the information both bodies held was from 1990 onwards, it gradually appeared that the missing documents had been sent to the National Archives in Oslo.

When the Langeland was flagged over to Norway in November 1990, having been under the Danish flag since February that same year, the Norwegian Maritime

Directorate gave the vessel a new file reference without linking this to the file reference the Directorate had for the vessel before it was out flagged. This meant that all the documents from before it was flagged out, were left in the files amongst deleted vessels, that is, vessels that were no longer Norwegian or had been lost. This category contained documents up to 2006, when the Marine Directorate was moved from Oslo to Haugesund. It was then transferred to a removal file which operated for some years after the Directorate moved to Haugesund. The documents on file that were moved to Haugesund were overwhelmingly for ships sailing under Norwegian flag. Once the removal archives in Oslo were closed down, documents that were not scrapped were transferred to the National Archives.

The documents at the National Archives gave the Accident Investigation Board all the underlying documentation that had been produced on the Langeland's stability in the first instance. As was said above, basic drawings and calculations on the hull and load line / freeboard were not available, because the Marine Directorate had not dealt with these specific areas since they were delegated to the classification society.

1.14.3 Correcting lightship for changes to the vessel and following these up

The Langeland had undergone many changes over the years which affected the ship's weight and centre of gravity, i.e. its lightship values; but no new inclining tests were ever carried out to update its lightship weight or centre of gravity. So no new updated stability calculations, i.e. load conditions were conducted after the changes.

The only inclining test the Langeland had undergone was in 1971 when the vessel was new. The test results were as follows:

Lightship displacement	799.30 t
Centre of gravity weight over keel (VCG)	4.79 m
Centre of gravity forward of aft perpendicular (LCG)	29.40 m

To provide the basis for working out new stability calculations, the Accident Investigation Board has calculated the weights and centres of gravity for all known changes in relation to the vessel's original calculations, that is, the point of intersection between the ship's longitudinal centreline, the baseline along the keel and aft perpendicular through frame 0, which is also the position of the rudder stock centre.

Weight calculations are basically volume calculations of the individual steel sections that were removed from, or fitted, on board the vessel. The volume multiplied by the inherent weight of the material gives the weight. For elements of a 'complex' shape (volume), the centre of gravity was calculated: for simpler forms, such as deck plates, the centre of gravity was established based on the profile drawings and plans and mid frame. The drawings show the vessel's internal steel structure as it was when the Langeland was built in 1971. Calculations were made for 71 elements in all.

The weight calculations indicated 71.2 t was removed from the vessel from when the inclining test was conducted until it was lost in 2009. Including the excavator on its traverse, the Accident Investigation Board concluded that 125.2 t of known weights were taken on board over the same period.

Changes to lightship as the result of conversions:

	Displacement [t]	VCG [m]	LCG [m]
Lightship 1971	799.3	4.79	29.40
Weight out	71.2	3.51	34.63
Weight in	125.2	7.14	24.02
'New' lightship	853.3	5.24	28.17*

* With excavator parked aft

Much of the 'weight in' in the table above was the excavator and traverse. The Langeland was approved generally from 1973 to carry up to 200 t deck load at a maximum VCG of 10.00 m, provided 2343 t was also stowed in the cargo hold. In 1977, the Maritime Directorate accepted that the excavator and traverse which together had a VCG lower than 10.00 m could be regarded as part of the deck load (cf. factual information).

The Accident Investigation Board has not found anything to indicate that ballast conditions with the excavator on deck were required to be worked out: so it was not documented or approved how much ballast water the Langeland had to have if the vessel sailed unloaded and with the excavator on deck.

The Accident Investigation Board assumes that each change to the Langeland was not individually considered as possibly having a 'significant effect on stability', so the shipping company did not require any new inclining tests, nor did the Maritime Directorate demand them. Removing the wooden dunnage in the cargo hold and removing the tweendeck hatches and main deck at the sides contributed to raising the lightship centre of gravity, as all the weights stated had centres of gravity that were lower than the lightship centre of gravity. Had these changes been considered together, together with the effects of the excavator on the traverse, it would probably have been more evident to both the shipping company and the Maritime Directorate that the changes had had a 'significant effect on stability', so new inclining tests should have been conducted and updated load conditions worked out. All the changes mentioned were made before 1982.

The Accident Investigation Board found details of the changes, such as removing the wooden dunnage, tweendeck hatches, and main deck on board, in the ship measurement documents, i.e. the tonnage calculations the Maritime Directorate conducted before issuing the test certificate. Like the Ships Control (the Maritime Directorate's inspection and survey division at that time) at the time, the Directorate's ship inspection offices were not located with the rest of the Directorate before 1982. Ship inspectors employed at the ship inspection offices and technical and expert ship inspectors employed by the Ships Control carried out their inspections on board vessels independently of one another, and mainly without their respective areas of responsibility or expertise overlapping. Nor did the Ship Inspection office report consistently to the Directorate's technical department,

including the stability office, any observations that might be material to a vessel's stability approval. Basically, any changes that would be relevant to stability should be captured by the Ship Control's technical ship inspectors.

Apart from the excavator, of which the Directorate was aware, it was therefore likely that neither the stability office nor Ship Control was aware of the changes above and that the shipping company did not tell the Directorate of them either.

Changes made after 1982, installing three bulkheads in the cargo hold, steel dunnage in the sides under the former main deck and removing the cargo booms, all contributed to lowering the lightship centre of gravity. This affected the stability, but generally favourably, and it is thus likely that no-one thought about whether it was necessary to conduct a new inclining test or update the load conditions.

The Langeland's first approved stability calculations from 1971 were calculated with 0.50 m of aft trim in fully-loaded sailing condition. The load was calculated homogeneously up to the shelter deck: that is, load in the hatch coaming volume was not included. The status was also calculated for a midship draught equal to 3.85 m, i.e. before open shelter decks.

None of the stability calculations subsequently approved included the longitudinal centre of gravity, so no trim was calculated. The calculations that were approved on 23 May 1973, however, had the volumetric centre of gravity for the load distributed homogeneously between the holds and hatch coamings, so they complied with the regulation requirements on maximum vertical positioning of load in the cargo hold, see section 2 above.

As early as 1973, the shipping company presented stability calculations made with the aid of what is called a stability instrument, which the company had on board the Langeland. Subsequent correspondence between the shipping company and the Directorate indicated that this instrument was a Consultas Ship Calculator STB no. 566. The printout from this calculator was extremely basic, and did not include either draught or trim, which makes it likely that it did not take account of the longitudinal centre of gravity. According to the printouts, the weight and VCG for cargo in the hold and on deck were given as input values in the calculations. For other variables such as tank content, only the weight was given. This means it was probably only the vertical centres of gravity for tanks that were entered in the calculator in advance. The current GM was calculated from these input values; this was compared with the minimum GM value that the vessel had to have for the stability requirements at its current displacement. If the calculated actual GM was equal to or greater than the minimum GM for the current displacement, the calculator would give "Maritime Directorate Requirements OK" or "NOT OK" if the current GM was less than the minimum. The calculator also indicated whether it had 'corrected for free liquid surface'.

Although the stability calculator that was used on board the Langeland early in the 1970s appears to have been extremely simple compared with today's load calculators, the file documentation states that this aroused attention in the media and elsewhere in connection with some specific shipments of high deck cargo that were made with the Langeland. The shipping company pointed out amongst other

things that there were hardly any other vessels of the Langeland's size which had the facilities to carry out such rapid and accurate stability controls as the Langeland had on board.

The Maritime Directorate did not accept the load calculator as an alternative to approved calculations, but it appears from the correspondence that the Directorate regarded the calculator as a good supplement to approved calculations. As late as in the Directorate's last letter on stability of 1989, it was pointed out that, if deck cargo was carried over 200 t, they assumed the Langeland's stability was checked using the calculator. If the calculator was no longer in use, the Maritime Directorate required new stability calculations to be submitted for approval.

The Accident Investigation Board does not doubt that the calculator was a good aid in checking the Langeland's transverse stability, especially if carrying heavy deck cargo; but the fact that the Langeland was better equipped to check its stability than most comparable vessels in the 1970s and 1980s probably contributed to the fact that not enough attention was paid to producing complete updated stability calculations and having them approved. Complete calculations, that is, including calculating trim and updated to allow for all physical changes, including new inclining tests as the Construction Regulations required, were never conducted for the Langeland.

1.14.4 New stability calculations

To get an overview of the Langeland's stability status in relation to the rules and how it was before it was lost, the Accident Investigation Board had to have complete new stability calculations carried out. These were carried out by the Wärtsilä Ship Design company, Fitjar, using NAPA calculation software which the Maritime Directorate approves for calculating both intact and damaged stability and tonnage.

The calculation model with hatches, deck house, tanks and cargo holds was worked out using the original span pattern for aft and foreship, general arrangements, centre span drawings, profile and plane drawings, tank plans and various photos which provided details of the cargo hold geometry, including the steel dunnage under the former main deck and the confinement bulkheads which did not exist in previous drawings.

Basing the calculation model of the Langeland on the same waterline as during the inclining test in 1971 and revised original inclining test report with hydrostatic data from NAPA for the stated waterline, NAPA gave lightship results as follows:

	Displ. (t)	VCG (m)	LCG (m)	V.mom. (t-m)	L.mom. (t-m)
Lightship in report 1971	799.3	4.79	29.40	3829	23499
NAPA corrected lightship 1971	777.3	4.93	29.64	3832	23039
Weight added :					
Known weights taken onboard	125.2	7.14	24.02	894	3007
Weights Removed :					
Known weights taken ashore	71.2	3.51	34.63	250	2465
New lightship after conversions	<u>831.3</u>	<u>5.39</u>	<u>28.37</u>	4476.7	23581.4

The difference between the two lightships found in 1971 in the table above is due to differences in calculated hydrostatic data between the original hydrostatic curve sheet from 1969 and corresponding data calculated using approved NAPA software in 2011. The most striking difference was that the VCG for lightship from 1971 would have been 4.93 m, i.e. 14 cm higher than calculated in the inclining test report of 1971.

1.14.5 Load conditions after loading in Sweden

To obtain the load conditions at the time the vessel was lost, we had to start with the conditions after loading at the quay in Sweden.

The conditions were shown as C01 – leaving port – Excavator forwards. 21 December 2011, see annexes.

From the information the Accident Investigation Board has received, 2353 t of diabase stone dimension 50-130 was loaded. The specific gravity of diabase of this dimension and homogeneity is 1.6 t/m³ and 2.9 t/m³: that is, there was 45% empty space per unit of volume between the stones in the cargo hold.

The investigations did not achieve a complete overview of how the cargo was stowed, but the information available indicates the diabase was stowed to more or less the same vertical level forward and aft of the cross-ship bulkhead amidships. It was also levelled out towards the sides and forward to the foremost trapezoidal hatch cover, which was not usually lifted when loading and unloading. From the aft of this hatch cover at frame 80.5 where the hatch coaming bends over, it is assumed that the stone followed its angle of repose of approx. 45° down to the tank top.

The loading weight used forward and aft of the midships bulkhead in condition C01 thus emerges from the guidelines above, and differs to some extent from the load plan the shipping company submitted, which shows that 1478 t and 875 t were loaded aft and forward of the midships bulkhead. The corresponding weights in condition C01 were 1413 t and 940 t respectively.

The shipping company has stated that loading down to domestic freeboard, i.e. to a draught equal to 5.625 m, was not used in the vessel's last years before it was lost, because the port area where the diabase was loaded gradually became shallower. It was therefore loaded to international summer freeboard, i.e. to a depth equal to 5.400 m. They probably tried to load in such a way that they achieved even keel at

the quay and with the excavator forwards. Having sailed into rather deeper water, the excavator was usually run aft and parked and secured in front of the deck house, giving an aft trim which experience shows is considered ideal. The Accident Investigation Board assumes this was also what was done before the vessel was lost.

The ship sailed from the loading port on 29 July 2009 at 15.20. On 30 July, at 08.00, the Langeland reported to the shipping company that they had 13 m³ fuel oil, 1.72 m³ lubricating oil and 12 m³ fresh water on board. They said they were using 208 l/h fuel oil at a speed of 10.5 knots. From this, we assume they had used 3.50 m³ of fuel oil from departure until 30 July at 08.00, so they had 16.5 m³ when they sailed. It is also assumed they had used 1 m³ fresh water, so they had 13 m³ when they sailed. It is assumed they had the same amount of lubricating oil as when they sailed, i.e. 1.72 m³.

Condition C01 shows that a fictive weight, lightship increase, of 83 t must be added to give a draught equal to 5.400 m with the guidelines as stated above. Such a lightship increase is also known as an 'age allowance', and is very common. Most vessels get heavier over the years, as many layers of paint are applied, more stores and loose equipment are generally brought on board than it is brought ashore, repairs are made by way of doubling plates, etc.

The size of the Langeland's 'age allowance', at 83 t, was well over what might be expected, however. On the other hand, it had been 38 years since the vessel's weight had been 'measured', i.e. its lightship displacement established by inclining test. The Langeland was probably not completely finished when the inclining test was held in 1971. From the original inclining test report, it appears that system oil and water, consumables, spares, anchor and loose chain and sundry equipment totalling 6 t would be taken on board after the inclining test: so these six tonnes are included in the original lightship of 799.3 t and corrected lightship (NAPA) of 777.3 t. On the other hand, the fact that these weights were to be on board after the inclining test indicates that the Langeland was not completely finished, and that the weights of items such as 'sundry equipment', 'spares' and 'consumables' may have been underestimated and a great deal may have been overlooked.

Much of the weight information the Accident Investigation Board has calculated for known changes, weight in 125.2 t, weight out 71.2 t, is taken from the ship measurement documents: so it may be likely that changes made which did not affect measuring the ship, and which were not reported to the Maritime Directorate, are included in the 'age allowance' as untraceable weights. The Accident Investigation Board has not made any further investigations to verify the 'age allowance'.

If the stability calculations have to be corrected for an 'age allowance', i.e. no new inclining tests were conducted in which the resulting lightship weight includes the additional weight, the additional weight is usually positioned at the known lightship centre of gravity G. Such an addition could, of course, have its centre of gravity other than at the lightship centre of gravity, both vertically and longitudinally, but it is generally accepted in shipping circles that vessels 'put on weight evenly', so the centre of gravity remains.

Condition C01 shows that the lightship increase is located at the lightship VCG, but not in the lightship LCG. From the requirements relating to an even vertical cargo level, the vessel would have trimmed forward in this condition: so the 'age allowance' is used to trim the vessel aft, back to an even keel. This is in principle different from the practice above, but with all the uncertainties concerning the many unknown weights on the Langeland that were added and removed, the Accident Investigation Board regards the solution as acceptable. The alternative would be to put much more of the load aft of the midships bulkhead than forward of it, so the difference in the vertical level of the cargo forwards and aft would be approx. 1.10 m. Such a difference was not in line with the main points of the information the Accident Investigation Board has had access to on loading.

The vertical level for the top of the cargo in condition C01 is approx. 1.40 m below deck and 2.40 m below the top of the hatch coaming. The cargo of 2353 t occupied 1470.6 m³ of the cargo hold space available, which totalled 2708.6 m³. The stone mass included 45% empty space, which came to 661.8 m³: so just 30% of the cargo hold space available was filled with stone. There was also space behind the perforated bulkhead forwards, midships and aft in the cargo hold, totalling 90.7 m³. These spaces could not be used for cargo, but would be filled with water which got into the cargo hold.

1.14.6 Condition at time of loss

This condition is stated as C02 – Loading conditions prior to loss – Excavator aft 21 December 2011.

These loading conditions describe the basic conditions assumed around 03.30 on 31 July 2009, a good 36 hours after leaving the loading port. The Langeland changed course abruptly to starboard at 03.54, and reported she was listing 10-12° and had water in the cargo hold at 04.19. The AIS signal from the Langeland disappeared at 05.22. These conditions thus represent a base point from which to find the cause of the list and what then happened until the vessel was lost.

Condition C02 differs from C01 in that 6.5 t fuel oil and an assumed 2 t of fresh water had been used in the 36 hours since the vessel sailed from its loading port. The condition is also based on the excavator being parked aft, giving an aft trim of 0.64 m.

1.14.7 Water level alarm in the cargo hold

The stability calculations which the Accident Investigation Board has had conducted are based amongst other things on load tables for the cargo hold with a cargo of stone. This allows for the fact that the water in the cargo hold will distribute itself in the spaces between stones and behind the perforated bulkhead over the whole length between frames 25 and 96.

The Langeland had high water level alarm sensors in the cargo hold at the bulkhead at frame 25. These sensors were mounted 0.50 m above the tank top. From the level table above, at an aft trim of 0.64 m, the cargo hold had to contain 66.5 t of water before it would reach up to the sensors. This takes no account of the fact that other

calculations show that the vessel would trim forwards as the volume of water in the cargo hold increased. Nor does it take account of the water moving in the cargo hold under the influence of the waves: so there could have been both rather more and rather less than 66.5 t in the cargo hold when the water level alarm went off.

1.15 Examining the practice on battening down hatches

1.15.1 Information from crew and management of the company

The Accident Investigation Board was informed by crew on the company's cargo vessels after the accident that practices relating to battening down hatches varied on board some of the company's vessels. Questions were asked in some cases whether it was necessary to secure the hatches completely if it was only for a short voyage in good weather, etc. In those cases, it was pointed out in no uncertain terms that hatches must always be secured. It has also been stated that failing to secure hatches properly was a practice which occurred at times a few years ago, but it had been emphasised in recent years that this was not permitted. It has also been stated that no differences could be seen in practice in relation to the nationality of the crew.

The shipping company's management have said they were very surprised that the hatches on the Langeland were probably not battened down. The company had procedures for battening down hatches that were described in the management system and departure procedures. The company was not aware this was a practice the crew did not comply with. The AIBN has also been informed that deviations in this area were not recorded in the company's monitoring system, but that the company management's ability to monitor what vessels did at sea was limited. The Accident Investigation Board has been informed that the company recruits crew via a manning agency: so the company assumed the crew were well aware of what hatches meant in terms of safety and therefore demonstrated what is known in shipping as good seamanship.

1.15.2 Information from the Coastguard

The Inner Coastguard was set up in 1996 with smaller vessels patrolling the coast. The Inner Coastguard had a number of monitoring and control functions, including working for the Maritime Directorate. The Coastguard's vessels monitored shipping in accordance with the Seaworthiness Act which was current at the time and now the Ship Safety and Security Act. Today, the Coastguard has partnership agreements with many public sector organisations in the coastal area, including a contract with the Maritime Directorate to report pollution observed from ships, overloaded vessels and other undesirable events. The Coastguard also conducts inspections on the Maritime Inspectorate's behalf.

When this service started, many occasions were reported of cargo vessels being found sailing with open hatches and/or overloaded. These reports went from coastguard vessels to the Maritime Inspectorate responsible for the district where the observations were made. Such observations have also been made and reported to the Maritime Directorate more recently, even if the extent seems to have been reduced.

The information AIBN has received from the shipping company's crew members thus seems to correspond to the opinion of the Coastguard, which has found that this problem has decreased in recent years. If fewer cargo vessels have been observed with their hatches open, this may be assumed to be connected to increased safety awareness, but it cannot be ruled out that this is because there are fewer coastguard vessels. Cases of open cargo hatches observed by the Coastguard and reported to the Maritime Directorate in recent years have been linked to overloading, and so cannot be linked directly to the Langeland accident.

1.15.3 Information from the insurers

The Accident Investigation Board has also been in touch with an insurance company to learn of their experience with insurance claims concerning water getting into the cargo hold. They say this problem is not unknown to them and that they follow up each and every case with inspections at the site. They cannot say anything about why cargo holds should leak, however, nor do they have any statistics on the matter.

1.15.4 IACS REC 015 "Care and survey of hatch covers of dry cargo ships - Guidance to owners"

The International Association of Classification Societies Ltd. (IACS) is an international organisation of 13 classification societies which between them classify more than 90% of world tonnage. IACS recommendation 015 covers maintenance and inspection of cargo hatches on dry bulk cargo ships. The introduction to the recommendations states that loss of watertight integrity continues to be a constant factor which leads to cargo being damaged, and that this can constitute a threat to the safety of the crew, the ship and its cargo. The classification companies are concerned about this problem, especially in the light of the Load line convention.

They point to two causal factors in particular in connection with leaking cargo holds:

- Damage resulting from using the hatch cover system normally, such as hatch coamings or covers being deformed as a result of external factors, particularly in connection with loading operations. They also mention normal wear and tear to the cleat arrangement.
- Poor maintenance, such as failure to corrosion-proof properly, lubricate moving parts, failing to replace old gaskets, using cleats and gaskets which do not meet hatch cover manufacturers' requirements, and improper repairs.

The IACS says there are increasing numbers of reports of damage of cargo due to water getting into cargo holds.

1.15.5 Research and literature in the field of practice and compliance in shipping

In a survey based on interviews with ships' officers in a Norwegian shipping company, Lamvik, Wahl and Buvik (2010) found it was not uncommon for there to be differences between what was written in a company's management documents,

training manuals, engine manuals and guidelines and what was actual practice on board that company's ships, even though the company's management documents were well known amongst the officers. The survey authors believe these differences could be explained by 'silent deviations', 'necessary breaches', 'practical drift' and 'silent knowledge'. The fact that the onshore organisation (shipping company) and ships are some distance apart may make it more likely that subcultures arise on board. Informal standards are established for how jobs on board can be done 'their way' of which the onshore organisation is unaware; a 'silent knowledge' emerges which only those on board know. The authors describe how the seamen's culture puts a high value on being able to resolve problems on board as they arise without referring to the organisation onshore.

In section 8 of his book, "Robust working practices. How come there aren't more accidents?" [Robust arbeidspraksis. Hvorfor skjer det ikke flere ulykker?], Ranveig Kviseth Tinmannsvik writes about "Silent deviations – threat or opportunity?" [Stille avvik – trussel eller mulighet?] She describes 'silent deviations' as informal non-conformities. This means that a working practice develops which departs from procedures or job descriptions to a greater or lesser extent. Tinmannsvik points out that 'silent deviations' may present risks because they have not undergone the same assessment, with a view to possible mitigating action, for example, as formal non-conformities.

In another article, Bye and Lamvik (2007) say there is a clear mismatch between perceived risks and formal levels of risk for smack fishermen and crew on board offshore service vessels. Bye and Lamvik believe this indicates that people in these occupations do not worry about being exposed to accidents, nor do they see it as likely they will be exposed to them. The authors point out that this mismatch is not in line with other research, which shows by and large that levels of perceived risk amongst those working in an organisation is normally a good indicator of the objective levels of risks in that organisation. Bye and Lamvik believe one possible explanation may be that denial of the high risks can be a survival factor in such occupations. If workers focus on how much risk they are exposed to in a high-risk occupation, they may be unable to pursue that occupation. They also point out that those with less experience on board see themselves as less safe than those with more experience. The authors point out that an unstated subjective underestimation of risks as against objective risk levels may be one form of a cultural group code in seamen's culture. They also point out that there are differences between national cultures in terms of what are perceived as risks.

1.16 Implemented measures

Immediately after the loss, the shipping company tightened up departure procedures. This involved the captain always verifying that the pre-departure checklists were followed. That was mainly to check that the hatch covers were properly secured.

2. ANALYSIS

2.1 Introduction

Shortly after the Langeland passed Väderöarna on its way northwards, the vessel suddenly altered course 90° to starboard and made straight for shore. After six minutes she turned to port and made for the Kosterfjord. The captain contacted the shipping company about 20 minutes after setting course for the Kosterfjord, saying the Langeland was listing 10-15° to port. The captain also told the company he intended to go into the Kosterfjord to seek shelter, so they could get a better idea of the situation. The owner also think he remember the captain saying they were pumping water from the cargo hold. That call was made about an hour before the vessel was lost. The weather conditions at that time were wind south-westerly 17 – 21 m/s and significant wave height around 5.5 m.

The Langeland's last known position is based on when the AIS signal was sent at 05.21.40 on 31 July 2011. The vessel was on a northerly course at that time, and had a speed of approx. 8 knots. The wreck of the Langeland is lying on the bottom approx. 160 m north of the ship's last registered AIS position. The Margita passed the Langeland immediately before it was lost, but did not observe anything unusual other than the extremely high seas for that time of year.

No emergency calls were received from the Langeland on the night of 31 July 2011, except that the vessel's free-float emergency beacon was activated. This and the extremely short distance from where the vessel was on the surface at more or less normal transit speed to where the wreck is lying on the bottom indicate that it was lost very quickly.

This analysis covers the Langeland's longitudinal trim, transverse stability, buoyancy and watertight integrity, and tries to use these conditions to explain what happened when the vessel sank. Given the prevailing weather conditions, it was also natural to look at how these affected the vessel. The analysis also seeks to find answers as to why the vessel was listing when it was lost and the water in the cargo hold which led to its changing course towards Kosterfjord.

2.2 Examining the course of events when the vessel sank

Before it was lost, the Langeland was listing and very probably had water in the cargo hold. The captain was in contact with the shipping company three minutes before the vessel sent its last AIS signal. The situation was still pending at that time, but the owner say there was nothing in this call to indicate the situation on board was dramatic.

The Langeland is lying on the seabed approx. 160 m north of where it sent its last AIS signal. The vessel was on a steady course at that time, speed around 8 knots. The Accident Investigation Board reckons this indicates it was lost very quickly.

ROV and AUV investigations of the wreck show the vessel standing on its keel, listing somewhat to port at around 075°. The vessel hit a slope falling (at 13°) from southeast to northwest. The vessel's bow have buried itself in the mud and thrown mud up around the bow section. This could indicate the wreck hit the bottom with considerable force and bow first. The area of damaged seabed is significantly more pronounced on the southeast side of the wreck, i.e. higher up in the terrain.

The cargo hatch covers are no longer in position on the vessel, but two hatch covers are inside the cargo hold, and two were found in front of the vessel. There are also some smaller objects close to the ship which may be parts of cargo hatch covers or cargo hatch covers buried partly in the mud. It is very probably the traverse for the excavator, which is over to starboard of the bows (Fig. 21). The excavator is not visible in the pictures, but the Accident Investigation Board thinks it likely it may be under the traverse.

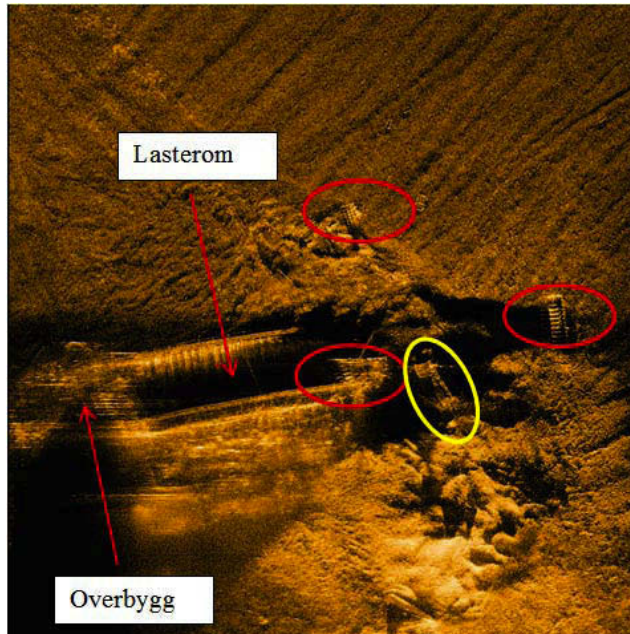

Figure 21: Wreck on bottom with bows at approx. 075. Hatch covers ringed in red, traverse ringed in yellow. (Photo: FFI)

The Accident Investigation Board does not consider it very likely that the vessel rolled over.

This theory is supported by the ROV investigations of the wreck, where the chains which pulled the excavator along the longitude of ship are mainly found lying in channel sections on the hatch coamings. If the vessel had been heeling badly when it was lost, the chains would most likely have slid out of these sections, and the traverse for the excavator and hatch covers would probably not have been in front of the wreck. Had the ship capsized, these and the excavator would be more likely to have gone overboard abeam and so be lying aft of the wreck on the bottom.



Figure 22: Traverse chains for excavator. Picture from port side. (Photo: KBV)

For the Langeland to have been stable enough not to have capsized, the Accident Investigation Board believes there may have been up to 200 t of water in the cargo hold. This load condition is shown as condition C04, and the reasoning for the maximum amount of 200 t is given in section 2.3 Listing – possible causes and consequences.

In its presumed condition until it was lost (C04), the Langeland had a remaining freeboard on the port side of approx. 200 mm. The draught amidships was 5.59 m with 0.32 m of aft trim. The excess bow height compared with the minimum bow height required was approx. 340 mm. With anything up to 200 t of water in the cargo hold, the vessel was lying deep in the water, but no deeper than domestic draught (5.625 m): so, apart from the list and the fact that there was water in the cargo hold, its condition may be described as relatively ‘normal’.

In addition to the above, the Accident Investigation Board also believes that the radio silence from the vessel and the observations by the Margita’s mate indicate that the Langeland’s condition was perceived as – and was - relatively normal, allowing for the fact that it was listing, had water in its cargo hold and the weather was bad.

Having altered course markedly to starboard at 03.54, the Langeland held a course (COG) of approx. 050° from 04.00 to 04.35. The waves then came right from aft. Towards the end of this period, the Langeland was passing through waters where the minimum depth is 28 m. The reduced depth is assumed to have affected the waves, reducing the wave length and making them higher. The wave velocity would have fallen, but the wave period would have remained the same. Calculations of the frequency with which the vessel met the waves that were measured, but with their length reduced to 70 m, gives 12 to 12.7 seconds as the Langeland varied its speed from 7.6 to 8.2 knots during this time. In other words, it was unlikely that the waves had any synchronous effect on the vessel’s natural periods for either pitching or rolling.

At 04.35, the Langeland changed course to approx. 020° (COG) and maintained this until the AIS signal disappeared at 05.21.40. From the wave records from Väderöarna at 05.00, the direction of the waves had turned more towards the west

than before, so they were coming in on the Langeland's port quarter during the end of the voyage. The estimated encounter periods of the waves, even assuming the wave length was reduced to 70 m, was so different from the Langeland's natural inherent frequencies for rolling and pitching that the likelihood of synchronicity is low.

The Langeland had both 7 and 13 m shallows against the wind on this last section. It is hard to say precisely how the waves were affected when they passed over these shallows: so the vessel may have been affected by waves which differed significantly from what wave records and assumptions indicate. It is well known, however, that there were choppy irregular seas breaking into these waters under the fierce southwest wind.

The mate on duty on the Margita which passed the Langeland heading south at 05.20 estimated the waves to be around 10-12 m high at the time. The estimated maximum wave height at Väderöarna at 05.00 was 7.9 m based on a measured significant wave height of 5.2 m. The average wave length was estimated at 90.7 m. Without attempting to quantify what the dominant wave height and length were when passing the Langeland, the stated figures and the certainty that the waves were choppy in these waters makes it clear that the Langeland was moving significantly at this time.

One of the significant vessel movements, yawing, is evident from the AIS data. The Langeland started yawing significantly from around 04.29 when it passed through the shallowest waters at 28 m. Not only the heading (HDG), but also the course sailed (COG) 'swung' significantly from side to side. In other words, it may appear that the Langeland was tending to shear off from its course (broaching) to starboard and port alternately. The Accident Investigation Board does not consider it likely that this was due to the heavy seas on the quarters alone.

The significant yawing may be because the auto-pilot had not adapted to the irregular wave pattern the Langeland was now in, and so produced excessive rudder movements. On the other hand, it is unlikely that the vessel continued on auto-pilot under this significant yawing. The Accident Investigation Board believes the yawing had other causes.

The fact that the Langeland was listing may have made it harder to keep her on course, but it is also likely that the forward trim may have contributed just as much. The forward trim may have arisen because:

- Much of the water in the cargo hold had accumulated forward of the cargo, in the empty spaces in the cargo hold and forward of the perforated bulkhead at frame 90. In the irregular seas the Langeland was in, there may have been many factors that led to more water accumulating forward. One possible factor may have been that some individual waves may have become as short as the vessel's length, approx. 70 m, increased in height and slowed down so that the Langeland was 'stationary' in those individual waves for some time. The lift of the aftership from the wave crest behind pushed the foreship towards the wave crest ahead, and may have accelerated the ship briefly then slowed it down immediately afterwards, causing more water to run off of the stern and forward

to the empty section of the cargo hold. When the wave crest aft then passed amidships and caused pitching aft, the water would have run aft again, but would probably have been slowed down by both the perforated bulkhead and the front of the stone cargo. It may therefore be likely that more water has run into the empty cargo space as the vessel pitched forwards than ran back into the stone as it pitched aft. This happened repeatedly and may have ended up with much of the water in the cargo hold accumulating forwards and causing the forward trim to increase, or

- More stone slid forwards, or
- More water got into the cargo hold. Load conditions C04 and C05 indicate that the vessel was trimming forwards as the volume of water in the cargo hold increased, but would have lost stability gradually if there was more than 200 t of water in the cargo hold. That would have meant it was more likely to capsize.

At around 05.07, the Langeland had the first of six major swerves which lasted until around 05.16. The Accident Investigation Board believes the vessel was already having major problems then, and significant forward trim. We can only assume that this was when the Margita observed that the deck lights on board the Langeland were on. The shipowners spoke briefly with the captain at 05.18, who said the weather was poor and they were still listing, and expected to have reached shelter in around half an hour. There was nothing in the call to indicate the situation was dramatic.

After the six major swerves above, the Langeland held a relatively steady course on 020° until 05.20.50, while its speed increased from something under 8 knots to just under 9 knots.

The Accident Investigation Board has AIS data up to 05.20.50, but the last AIS signal was sent at 05.21.40.

The increase in speed may indicate the Langeland was ‘riding’ a wave towards the end. According to reports from Väderöarna, the average wave velocity at 05.00 was estimated at 11.9 m/s or 23 knots: so there is no way it could have been riding such a ‘measured’ wave. On the other hand, the waters the Langeland was in at the time had chaotic and irregular wave patterns: so we cannot rule out the possibility that she may have ridden a temporary wave in the area.

The wreck of the Langeland is lying on the bottom approx. 160 m from where the AIS signal disappeared and on a ‘course’ of 075°. The rudder is set out to port.

Comparing the two facts as above, the Accident Investigation Board believes it is likely that the Langeland may have ridden a temporary short, high wave while veering to starboard at the same time. They tried to correct this veering by putting the rudder to port. Because of a possible thrust or lift from a wave on or below the aftership (‘wave riding’), the forward trim probably increased even more as more water ran forward in the cargo hold.

The Accident Investigation Board believes the Langeland's bow ultimately pushed into a wave, but the considerable forward trim and hence loss of bow height and reserve buoyancy forward meant it could not get out of such a situation. The thrust from the engines and the ship lifting aft under the effect of the waves probably pushed the bow further into the wave and down into the sea; at the same time, what was possibly left of the water in the cargo hold and stone swept rapidly forwards and made the situation irreversible.

2.3 Considering the list – possible causes and consequences

The captain of the vessel contacted the shipping company at around 04.19, saying they were listing 10-15° to port and that he intended to sail into the Kosterfjord to seek shelter. The shipowner also think he remember the captain said they were pumping water from the cargo hold. Fig. 20 shows the Langeland listing as stated.

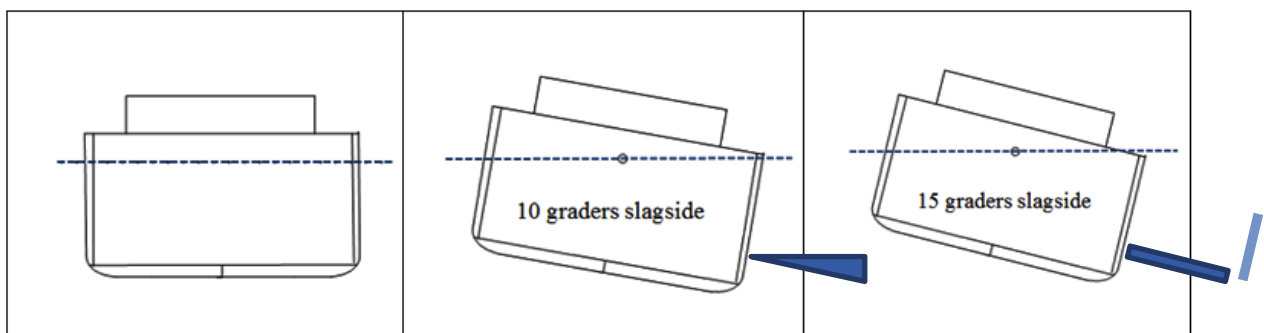

Figure 23: Section through the Langeland as it was loaded, at 0, 10 and 15° list respectively

The Accident Investigation Board has tried to find out how the list as stated came about, as this was probably why the Langeland decided to alter from its planned course and head for the Kosterfjord instead.

2.3.1 Water in the cargo hold

The Accident Investigation Board has carried out calculations to investigate whether water in the cargo hold could have caused the vessel to list to the degree the Langeland reported before it was lost. The conditions are stated as follows:

- C03 – Load condition prior to loss – heeling to port 16 November 2011
- C04 – 100 t seawater in holds 16.11.2011
- C05 – 300 t seawater in holds 16.11.2011
- C06 – 750 t seawater in holds 16.11.2011

The difference between conditions C02 and C03 is that all the fuel oil except the day tank moved over to the port tank to give a slight incipient list before 'seawater filled the cargo hold'.

Conditions C04-C06 show that the water in the cargo hold had a marginal effect on the list. Even with 750 t of water in the cargo hold as shown in condition C06, in which the deck is almost in the water and the righting lever GZ is entirely marginal, the initial GM is still as high as 1.26 m so that the vessel would not heel purely statically.

Given the evidence above, it is not very likely that water in the cargo hold alone caused the loss.

2.3.2 Cargo absorbing water

It is be conceivable that the stone cargo on the port side was saturated as a result of being sprayed repeatedly with water getting in through the hatch coaming and hatch covers as the waves crashed over the deck. The increase in weight of the saturated stone throughout the height of the cargo on the port side may in theory have induced a list as a result of limited amounts of water gathering at the bottom of the cargo hold would only affect the lower layer on the starboard side.

The general specifications available for rock types indicate diabase can increase its weight by up to 0.5% as a result of absorbing water. If water running down into the port hatch coaming met the load at a width of 2.0 m over the whole length of the load, this would mean that approx. 420 t of stone increased in weight by 0.5%. That could mean a heeling moment of approx. 12 tm, which would have resulted in an insignificant heeling.

2.3.3 Excavator moving

The traverse and excavator were parked in front of the deckhouse. We do not know whether the excavator itself was standing in the centre of the traverse before the loss or on the starboard side as shown in Fig. 5. If the excavator weighing 27 t had slid from its position to starboard across the traverse to port, that would have given a heeling moment of around 200 tm which would have given a heeling of 1.5-2°. The Accident Investigation Board does not believe the excavator movement in itself could have caused the list that was reported.

2.3.4 Shifting cargo

As the Langeland came north of Skagen and lost the shelter of North Jutland, the vessel was hit by increasingly larger waves from the southwest. The Accident Investigation Board has received wave data from a meter buoy west of Väderöarna where the depth is 73 m. Assuming a constant length, the wave readings from the Väderöarna were representative of the water from Måseskär northwards. At a steady speed of around 8 knots, the Langeland was west of Måseskär at around 23.30 on the 30 July 2009. This means that waves measured at the Väderöarna may be used for the approx. 4.5 hours of sailing the Langeland had west of Måseskär until she altered course markedly to starboard at 03.54. As the captain reported that the ship was listing and had water in the cargo hold at 04.19, relatively soon after altering course, the Accident Investigation Board believes the problems arose before she altered course.

Some wave data according to the report from SMHI based on readings off the Väderöarna on the 31 July 2009:

Kl.	Hs [m]	Hmax [m]	Tz [sec.]	Tp [sec.]	ThTp [°]	Lz [m]	Lp [m]	Cz [m/s]	Cp [m/s]

00.00	4.4	6.8	6.5	8.3	225.0	66.8	107.6	10.2	13.0
01.00	4.4	6.8	6.5	9.4	230.6	66.8	138.0	10.2	14.7
02.00	4.7	7.2	7.2	10.2	230.6	81.6	162.4	11.3	15.9
04.00	5.1	7.8	7.2	9.3	230.6	81.6	135.0	11.3	14.5
05.00	5.2	7.9	7.6	11.6	241.9	90.7	210.1	11.9	18.1
06.00	5.8	8.8	8.0	11.7	241.9	101.1	213.7	12.6	18.2

Hs, Tz, Tp and ThTp are measured by wave buoys. Other data calculated based on measured data.

Hs = significant wave height. Mean of largest one-third of waves over 30 minutes.

Hmax= maximum wave height calculated based on Hs and Tp.

Tz = average wave period

Tp = wave period for waves with greatest energy

ThTp= direction of waves with greatest energy. Indicates what direction they come from.

Lz = average wavelength, calculated based on Tz.

Lp = wavelength for waves with greatest energy, calculated based on Tp.

Cz = average wave velocity based on Tz.

Cp = wave velocity of waves with greatest energy, calculated based on Tp.

The Langeland had a course (COG) of 340° and maintained 8.1 knots on average over this period: so the waves were coming in at 20-25° from aft the port beam, exposing the vessel mainly to lifting and rolling movements, but also some yawing and stamping.

For waves hitting a vessel at right angles, the period at which those waves meet the vessel, Te (encounter period), is the same as Tz and Tp in the table above. The encounter period is then independent of the ship's speed. From the angle between the Langeland's course (COG) of 340° and the wave direction (ThTp), the wave velocity (Cz and Cp) and the vessel's speed, the encounter period for the average waves (Tez) and the waves with the greatest energy (Tep) is as follows:

Time	Tez [sec.]	Tep [sec.]
00.00	7.9	9.6
01.00	7.6	10.4
02.00	8.2	11.2
04.00	8.2	10.3

Calculating the Langeland's natural inherent roll period gives 7.1 seconds for the conditions shown in condition C02 where GM is calculated as 2.01 m. At condition C04, with 200 t of seawater in the cargo hold and an estimated GM of 1.53 m, the corresponding calculations give an inherent roll period of 8.1 seconds. By way of comparison, condition C02 with GM changed to 0.15 m, which is the minimum statutory requirement, gives an inherent roll period of 26 seconds.

A general rule for a vessel's ideal roll period is that the number of seconds should be approximately equal to the vessel's breadth in metres. In these considerations, we took the approach that such a roll period should be based on a GM which is presumably large enough for all stability criteria to be met while no larger than that the rolling motion is slow enough for the crew to find it harmonic, and that it does not involve major acceleration forces which might impose unwanted stresses on the

ship, its equipment or cargo. Based on this, we can say that the ideal inherent roll period for the Langeland with its breadth of 13.22 m would be 13-14 sec.

Based on the above, the Langeland must be seen as having been unusually rigid before it was lost. At an inherent roll period of 7-8 seconds, it may to some extent have been likely that the fast, choppy rolling alone led to the cargo shifting.

It was well known that a great deal of water gathered in the open space ('hatch locker') in front of the deckhouse when the Langeland was exposed to even moderate waves. According to the information the Accident Investigation Board has received, there was often water 'standing' in the 'hatch locker': that is to say, the water coming in over the deck and into the opening was often as much or more than what the bilge ports could drain. It was also well known that moderate waves came in over the deck and hatch coamings. With the damage to the rear of the hatch coaming and gaps between the hatch coaming and hatch covers because the covers were not toggled to the hatch coamings properly, the Accident Investigation Board believes water may have got into the cargo hold for some time and in lesser waves than the vessel encountered south of Måseskär.

The phenomenon of synchronous rolling is known to be most likely to occur in high waves where the wave direction encounter the ship abeam or on the quarter; and the vessel's natural inherent roll period must also approach the encounter period between the waves and the ship. The waves will then add energy rhythmically to the rolling motion so it does not stop gradually of its own accord. The roll angle will also increase significantly as a rule. Model tests in tanks for container ships with waves encountered abeam have shown this phenomenon can occur rapidly over just two or three roll cycles, and large roll angles of 50° or more are not uncommon. It has also been shown that an encounter period of, say, 9.5 sec for the waves and a natural inherent roll period of 10.5 sec for the ship may be close enough to one another for synchronous rolling to occur.

The encounter periods for the waves in the table above, especially T_z for the average waves from 02.00, and the Langeland's estimated inherent roll period, especially with water in the cargo hold, were close to one another at 8.2 and 8.1 seconds respectively. This makes it likely that synchronous rolling may have arisen, the ship rolling violently accordingly.

From the AIS data, the Langeland was yawing more than earlier from around 23.40 on 30 July. She was also 'heading more into the weather' from the same time in that the HDG (heading) was mostly 5-10° less than the sailed course (COG) of 340°. This means that it is likely that the Langeland, even with significantly less than 200 t water in her cargo hold, i.e. the inherent roll period was nearer to 7.1 than 8.1 seconds, may have started rolling synchronously with the waves coming in crosswise to port for a while. From the readings from the Väderöarna, the average wave period T_z was 7.2 seconds from 02.00. As was stated above, T_z becomes the same as the encounter period when the waves are hitting the vessel abeam.

Nor can the investigation disregard the possibility that water in the cargo hold, when shifting from side to side through the cargo of stone, may have come into an unfortunate phase in relation to the rolling. Water in the cargo hold, as well as water gathering in the 'hatch locker' on deck may therefore have been factors

which may have contributed to adding more energy to the roll and / or altered the inherent roll period so that it also synchronised with the waves with the greatest energy, T_p and / or T_{ep} in the tables above.

In view of this, the Accident Investigation Board believes it is likely that the Langeland may have been exposed to synchronous rolling, with rolling surges resulting. The cargo may probably have shifted as a result of such large, rapid rolling surges. Fig. 24 shows a ship rolling synchronously with the waves in the ratio of 2:1 (inherent roll period equals twice wave period).

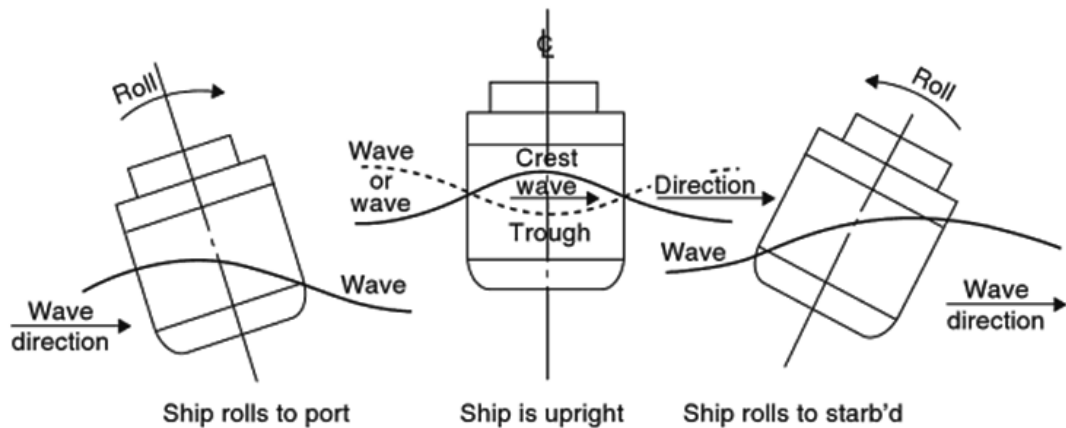

Figure 24: Ship rolling synchronously in a ratio of 2:1 (inherent roll period twice wave period)

Given that the listing that was reported may have arisen as a result of the cargo shifting under synchronous rolling, the Accident Investigation Board has prepared calculations involving the cargo shifting.

What most probably happened is that stone may have shifted completely at the front of the mass of stone, following its natural angle of repose of approx. 45° down towards the tank top. The calculations assume 100 t or 62.5 m^3 slid out on the starboard side. It is assumed the weight shifted forwards and over to port so it gathered down on the port side against the perforated bulkhead at frame 90.

It is thought that the weight that may have slid out had a transverse centre of gravity (TCG) of 4.00 m from the centreline to starboard. Given that the sides of the hull sloped out in the foreship (flare), the TCG for the shifted weight as it gathered down towards the tank top on the port side is estimated at 2.50 m to port of the centreline. The tilt moment resulting from this load shift was 650 tm. The calculations also assume that the total stone cargo forward of the transverse bulkhead had a reduced VCG and increased LCG as a result of the shift.

This condition is shown as: C03 – Last i forre rom raser ut 21.12.2011
(Cargo in forward hold sliding)

The shifting load resulted in the vessel listing 5.6° to port with its aft trim reduced 0.12 m. The list in this estimated condition is less than the $10\text{--}12^\circ$ that the vessel reported; but it must be assumed that it was difficult to assess precisely what angle she was listing at in the rough seas that the Langeland was in. Also, the figure of 100 t shifting was chosen randomly in the calculations: it may of course have been

likely that more cargo shifted, or that a larger amount of stone shifted in steps over time.

The assumed points of entry to the cargo hold in the shape of damage to the hatch coamings (provided the damage was already there at the time of the loss) and the gaps between the coamings and hatch covers made it difficult to estimate how much water may have got in over a given period. It is also uncertain whether the bilge pumps managed to keep up or whether the volume of water increased once the lower water level alarm was reached when the total volume of water assembled reached around 66.5 t. The Accident Investigation Board has therefore calculated the conditions as follows:

C04 – Forskjøvet last + 200 t sjøvann i rommene 21.12.2011 (Cargo shifted + 200 t seawater in holds)

C05 – Forskjøvet last + 400 t sjøvann i rommene 21.12.2011 (Cargo shifted + 400 t seawater in holds)

C06 – Lukekarm neddykkes - 445 t sjøvann i rommene 21.12.2011 (Hatch coamings submerged - 445 t seawater in holds)

The main feature of these three conditions is that the list increases merely from 5.6° to 7.2° in condition C05 with 400 t seawater in the cargo hold as well as the cargo shifting from condition C03. The deck on the port side would then be 11 cm under water as a result of the list. The righting lever GZ becomes extremely marginal at a maximum of 0.07 m when heeling 50° to port; but GM is still high, 1.60 m, so that the inherent roll period must be assumed to be the same as stated for conditions C02 and C04 above.

If the Langeland had been subjected to synchronous rolling with 400 t of water in her cargo hold, her residual stability when heeling to port would have been so reduced that the vessel would probably have capsized. It must therefore be assumed that there may have been considerably less water in the cargo hold when the Langeland changed course markedly to starboard and reported, some time later, that she was listing and had water in her cargo hold. With 200 t of water in her cargo hold and cargo shifted, condition C04, the Langeland met all the stability requirements, except that one of the values was marginally less than the minimum required. As a rough assessment, based on the above, the Accident Investigation Board believes that 200 t of water in the cargo hold would have been as much as the Langeland could carry and complete the voyage without capsizing until she reported she was listing.

From the reasoning above, the Accident Investigation Board takes the view that the list arose mainly as a result of the cargo shifting and that it is likely that this was caused by the Langeland being subjected to synchronous rolling with the wave period. The abrupt change of course to starboard at 03.54 may have been made to get the vessel out of a problematic situation with synchronous rolling.

By changing course from 340° first to 035° and then to 072° up until around 04.00, the waves were hitting the Langeland more from aft, first 75° on the port quarter, then 68° on the starboard quarter. She reduced speed to some extent at the same

time. This increased the encounter periods with the waves Tez and Tep to approx. 11.1 and 12.8 seconds respectively, which makes it unlikely that synchronous rolling could have arisen.

The Langeland's natural pitch period is estimated at 7.5 seconds in condition C02 (no water in cargo hold). As the inherent pitch period corresponds more or less to the inherent roll periods, the Accident Investigation Board believes we cannot rule out that a synchronicity may also have arisen in the waves affecting the pitch. The cargo would have shifted more easily had this happened.

2.4 Assessing trim and stability

The Accident Investigation Board has had load conditions (control conditions) prepared in accordance with Sections 6.3.3.3 and 6.3.3.4 of the Construction Regulations, the so-called homogenous conditions in which the cargo is distributed as laid down in Section 6.3.8.

These conditions were calculated for both international and domestic draught, at 5.400 m and 5.625 m respectively. They were also calculated with and without 'age allowance' ('UA'). The conditions are stated as:

HL1 - Homogenously loaded at 5.40 m – 100% Fo & Fv 21.12.2011
HL2 – Homogenously loaded (5.40 m) – 10% Fo & Fv 21.12.2011
HL5 – Homogenously loaded 5.625 m – 100% Fo & Fv 21.12.2011
HL6 – Homogenously loaded (5.625 m) – 10% Fo & Fv 21.12.2011
HL1_UA – Homogenously loaded at 5.40 m – 100% Fo & Fv 12.12.2011
HL2_UA – Homogenously loaded (5.40 m) – 10% Fo & Fv 12.12.2011
HL5_UA – Homogenously loaded 5.625 m – 100% Fo & Fv 12.12.2011
HL6_UA – Homogenously loaded (5.625 m) – 10% Fo & Fv 12.12.2011

These calculations uncovered that under none of the control conditions did the Langeland satisfy the requirements of Section 6.4.3 of the Construction Regulations that *the angle of list at which the righting lever (GZ) is greatest should be greater than 30° and must never be less than 25°*. This was not evident from the calculations from the 1970s, probably because the calculation documents were inaccurate or inadequate. For example, the only hydrostatic and form stability data available were for 0 trim (even keel). To ensure that inaccurate and inadequate calculations have not led to corresponding design errors in other cargo ships, the AIBN believes that consideration should be given to requiring all cargo ships in NOR and NIS which have not had calculations made using approved software to produce new complete trim and stability documentation.

Another uncovered aspect was that all control conditions had a relatively large value of forward trim. This was not evident from previous calculations, as calculation of trim had been neglected.

An overview of the calculation results for the two conditions above appears in the table below. It should be added that, if full calculations had been made in the 1970s, the forward trim would have been even greater than shown in the table. That is because the perforated transverse bulkhead was not installed until 1982. The

conditions shown in the table are not calculated with cargo forward of that bulkhead under the former main deck.

Condition	Forward trim [m]	Angle of heel at which maximum GZ occurs [°]
HL 1	0.26	19.5
HL 2	1.35	22.5
HL 5	0.52	17.9
HL 6	1.57	19.0
HL 1 UA	0.42	21.6
HL 2 UA	1.50	22.8
HL 5 UA	0.67	20.7
HL 6 UA	1.73	19.7

As the matters above should, ideally, have been discovered and corrected when the vessel was new, the Accident Investigation Board will use conditions calculated without age allowance in further assessments. The Langeland's history shows that loading to domestic draught was vital for a commercially viable operation of the vessel as late as 1996: so we will use conditions HL 5_UA and HL 6_UA as the basis in what follows below.

The minimum bow height from the forecastle deck under the rules of the Load Line Convention of 1966 was 3.084 m. The forecastle deck's height over the forward baseline was 8.85 m. Excess bow height over regulation bow height is obtained as follows: $(8.850 - 3.084) - 5.625 = 0.141$ m. Under Section 6.3.6 of the Construction Regulations, forward trim can be accepted at 30% of excess bow height, i.e. 0.042 m which is also less than 0.5% of the length L (64.11 m).

Acceptable forward trim of 0.042 m contrasts sharply with what is calculated in condition HL 5_UA, 0.67 m. For the Langeland to meet the regulatory requirements in terms of forward trim, it would have had to be rebuilt. Either the underwater hull forward should have been made considerably bigger, or a new really watertight cargo bulkhead should have been installed. The latter would probably have been chosen. Given the shipping company's experience that bulk cargo could not be stowed further forward than shown in condition C01 to avoid forward trim, it is likely that complete stability calculations would have also led to the conclusion that a new cargo hold bulkhead had to be installed well aft of frame 90. That would have meant shortening the load hatch. The Accident Investigation Board has not calculated any regulatory conditions which meet the regulatory requirements and which would have indicated the bulkhead location.

Under the Construction Regulations, the requirements in terms of forward trim and bow height also applied to arrival condition HL 6_UA. Section 6.3.7 of the regulations permits using ballast water (compensating for fuel oil and fresh water used) in this condition to meet stability and / or trim requirements. Despite this, it is not unlikely that the formidable forward trim in this condition, 1.73 m, would determine how far aft a new forward cargo bulkhead had to be installed.

The fact that none of the regulatory conditions met the requirement that the maximum righting lever GZ should occur at an angle of heel greater than 30° and that this angle of heel must never be less than 25°, was due to there not being enough freeboard. The total reserve buoyancy including the forecastle head, loading

hatches and superstructure aft was not enough to meet this stability requirement. The simplest solution would have been to reduce the draught to increase the freeboard and reserve buoyancy, but this would probably not have been feasible if the vessel was to be operated in a commercially viable manner, as was stated above.

Another solution would have been to install permanent ballast. The projection calculations which the Accident Investigation Board has had prepared show that around 145 t ballast would have had to be added to meet the stability requirement in the departure condition. The fixed ballast would be lost deadweight, and we may assume this option would not have been chosen out of concern for commercially viable operation.

If this defect had been discovered in the 1970s or 1980s, the Accident Investigation Board suspects that the Langeland might have been rebuilt, increasing its reserve buoyancy, for example by lifting and / or extending the forecastle head and recladding the ‘hatch locker’ to achieve a watertight, buoyant space. This last modification would have required changing the hatch layout, but as shortening the hatch coamings as a result of the requirement for a new forward cargo bulkhead would also have required such a modification, we cannot disregard the possibility that it would have been chosen as a joint rectification of both design faults. Building up (lifting) the shelter deck along the hatch coaming might have been an alternative.

The Accident Investigation Board believes that if the physical modifications to the Langeland had been followed up with inclining tests and updated load conditions, such calculations in the late 1970s / early 1980s would to an increasing extent have been carried out using calculation software which was increasingly detailed and precise compared with the stability calculations that were worked out manually for the Langeland in the early 1970s.

With more details and precision, and the fact that calculating trim was a natural component of the “modern” calculation tool, both design faults in the Langeland described above would probably have been discovered as early as the late 1970s.

The reasoning above assumes that the requirements of the Construction Regulations of 1969 or 1979 were met. If the Construction Regulations of 1987 or 1992 had been applied, the incorrect location of the forward cargo bulkhead would probably not have been discovered because the provisions on maximum forward trim / minimum bow height had been omitted from those regulations.

As the provisions on forward trim / minimum bow height were omitted in the 1987 and 1992 regulations, ships built after 1987 have been or will be constructed with their forward cargo bulkheads located too far forward. The AIBN believes action should be taken to prevent this, and the Accident Investigation Board therefore believes the provisions on maximum forward trim / minimum bow height should be reintroduced.

Investigating the loss of the Langeland has also uncovered that the vessel’s lightship data has changed significantly since the vessel was built in 1971. Condition C01 shows that a fictive weight of 83 t would have to be added to make up for the age allowance.

In all the calculations made during the investigation into the vessel's condition at the time it was lost, the age allowance is added aft at the rudder stock, making the calculations conservative in terms of forward trim. The Langeland may therefore have had more forward trim than shown by the calculations.

The Accident Investigation Board would point out that an age allowance which is not known or corrected for will generally create uncertainty in terms of trim and stability. This means that the vessel's stability documentation as used for preparing operational assessments would not be reliable.

Even if the size of the Langeland's age allowance (83 t) was well over what one might expect, and could be rather less as a general rule, the AIBN believes regular inclining tests or displacement measurements should be conducted to discover any age allowance and set correct lightship data. The AIBN would also point out here that regular inclining tests or displacement measurements are already required for certain passenger and fishing vessels.

2.5 Assessing watertight integrity

The Accident Investigation Board's investigations have also focused on the vessel's watertight integrity. One area considered was the vessel's hatch coamings with their associated hatch covers and cleats, and the jacks for the hatch covers.

As it sailed northwards, the vessel sailed into an area where the wave height was steadily increasing. Until the Langeland changed course towards the Kosterfjord, the vessel had the waves slightly aft of the port beam. The figure below shows a scaled sketch of the vessel in the beam waves coming from Väderöarna northwards.

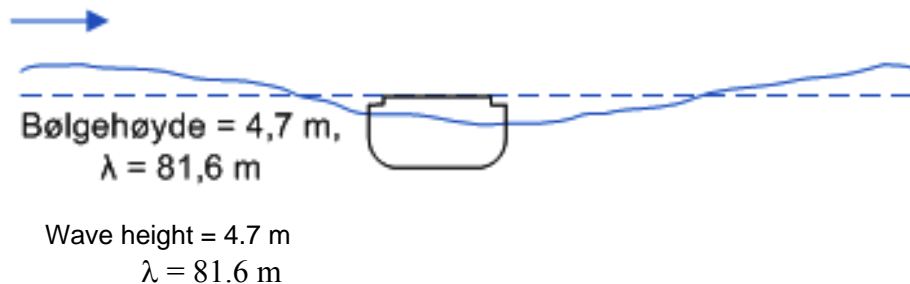
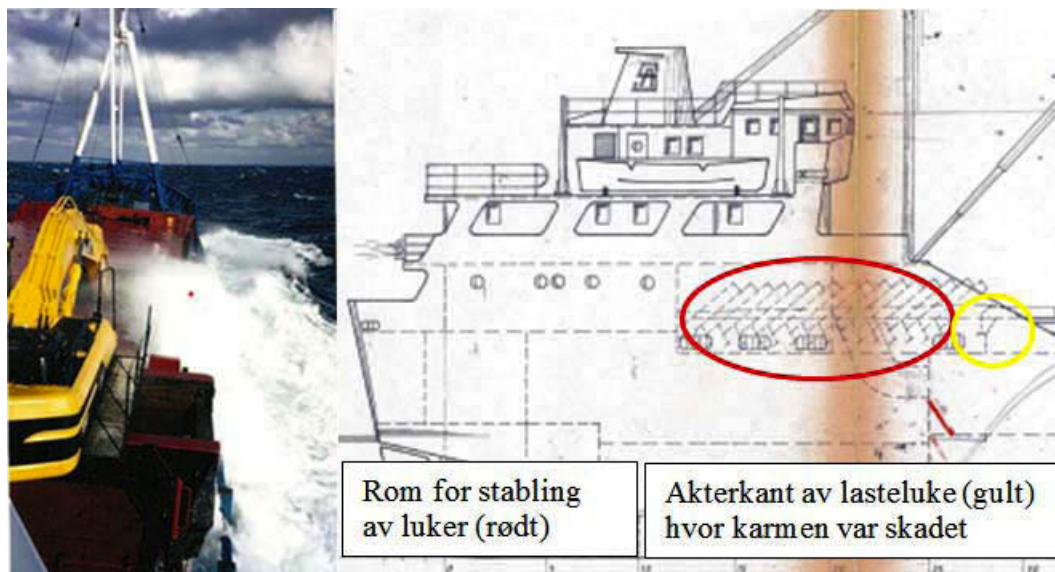

Figure 25: Sketch showing vessel with sea abeam.

As the vessel had little freeboard, we may assume that the vessel was exposed to excessive seas on deck. Information from discussions with the shipping company confirms that the vessel would have been exposed to water on deck more or less continuously in its loaded condition and under the sea conditions prevailing at the time. The image below shows the Langeland sailing earlier with cargo on board. The space in which the hatches were stacked during loading and unloading may be assumed to have been partly filled with sea water.



Space for stowing hatches (red)

Rear of cargo hatch (yellow) where coaming was damaged

Figure 26: On left, the Langeland with cargo on board on a previous trip in following sea with the deck almost continuously under water. The sketch on the right shows the area where the hatch covers were stacked during loading and unloading. The sketch also shows the rear of the hatch coaming where damage was observed (yellow ring).

2.5.1 Damage to aft hatch coaming

The ROV investigations conducted on 8 August showed that the hatch coaming was damaged aft. The ROV image shows that the upper section of the hatch coaming has been pushed down and buckled in towards the cargo hold (forward). The image also shows a cleat that was torn off. The shipping company held an inspection on board the vessel in Gudvangen on 15 July 2009, and confirmed the hatch coaming was not damaged at that time.

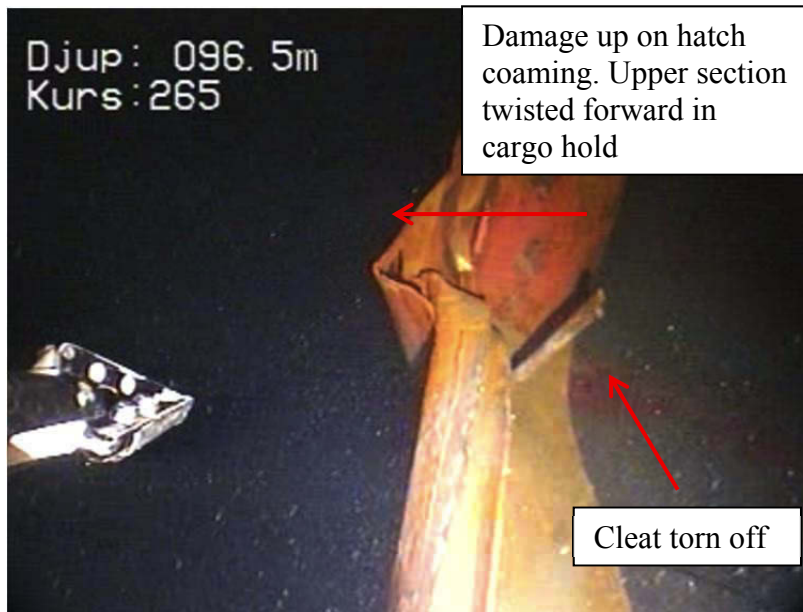

Figure 27: Damage around centre of hatch coaming aft.

The damage to the hatch coaming must therefore have arisen during the loss or between the vessel's last inspection at Gudvangen on 15 July and the loss of the vessel.

Behind the hatch coaming, in under the forward part of the superstructure, is the hatch chamber in which the hatch covers were stowed during loading and unloading. In interviews with the shipping company, it emerged there was normally nothing in this space that could have slid forward and damaged the hatch coaming.

The images from the ROV investigations show the hatch covers are gone, and it is only natural to wonder if the damage may have occurred when they disappeared. The AUV investigation findings indicate that the hatch covers slid forwards. At the back of the cargo hold, the hatch coaming is considerably lower than the hatch coamings on either side.

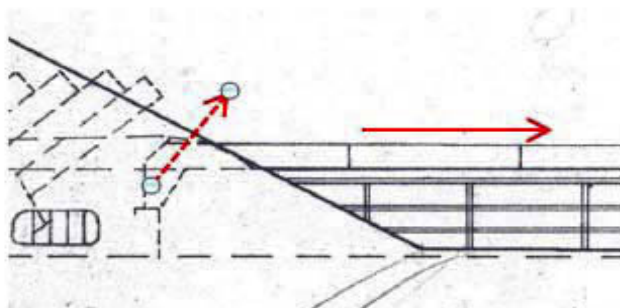

Figure 28: Sketch showing aft section of the Langeland's hatch coamings, the aft-most hatch covers and front of the space in which the covers were stowed during loading and unloading.

Given the coaming design, the Accident Investigation Board believes a scenario in

which the hatches rush forward would mean that the aft-most of the aft hatch covers would move naturally upwards and forwards. That would hardly cause damage to the hatch coaming except in the space as shown in the figure above. If the vessel had capsized (180°) and the hatches had fallen off, such a scenario would hardly have led to the damage that appears in the picture. The cleats in the picture do not appear to have buckled.

Another scenario could be that the damage occurred while levelling the cargo at the rear of the hold, with the grab on the excavator accidentally hitting the hatch coaming from above and with a slightly forward force. However, it is only limited space between the hatch coaming and the covers stowed in the hatch magazine, and the Accident Investigation Board cannot establish this with any certainty.

The investigations indicate that the damage to the hatch coaming on the Langeland probably did not occur when it was lost. The damage may have been such as to impede battening down the hatches: that could explain why the hatches were not battened down. On the other hand, the damage should have been reported to the shipping company (it was not), and the Langeland should not have continued until it was rectified. However, literature available (Lamvik, Wahl and Buvik (2010)) describes how the seamen's culture greatly appreciates being able to resolve problems on board as they occur, without consulting the organisation ashore.

The Accident Investigation Board believes the rear hatch coaming may have been damaged when the Langeland sailed from Stårnøkrossen and headed for Moss. Given the weather conditions that developed during the voyage, with it being likely that there were considerable quantities of water on deck, this damage, in addition to lack of proper securing of hatches, may have contributed to the vessel's cargo hold filling gradually.

2.5.2 Securing hatches

To pull the hatch covers back into the space where they were stored while loading and unloading, the covers are fitted with two wheels on each of their short sides. The hatch covers roll over the hatch coamings when the hatches are operated. When securing the hatches, they are run into their given positions and the hatch jacks lowered, lowering the covers onto the coaming. The covers are rendered watertight by hammering in wedges over the covers and fitting or tightening the cleats on the short sides of the hatch covers.

Hatch jacks

The images from the ROV survey show that the hatch jacks on the starboard side are in the lifted upper position and those on the port side are in the lower position, which would be normal when the hatches are on.

Hatch lowered jack in position Hatch raised jack in raised position

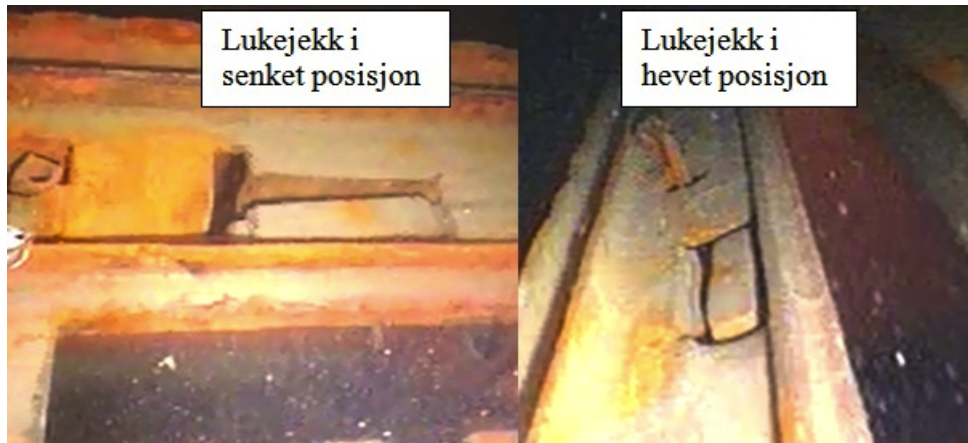

Figure 29: (Left) One of the hatch jacks on the port side. (Right) One of the hatch jacks on the starboard side. (Photo: KBV)

The Accident Investigation Board cannot say with any certainty whether the hatch jacks on the starboard side were in the upper position or whether this happened as a result of the foundering.

Cleats

The Accident Investigation Board cannot say with any certainty which cleats may have been fastened or what condition they were in. The overview of the condition of the cleats that could be seen when investigated by the ROV shows the hatch covers were not properly secured or made ready for sea. Given the weather conditions that developed during the voyage, with the probability of significant amounts of water on deck, failing to secure hatch covers properly, probably contributed to the vessel's cargo hold gradually filling with water.

2.5.3 Probability of steel structure collapsing, cracks in outer skin

The Accident Investigation Board has studied video recordings of the wreck of the Langeland. Only the upper sides of the hull were accessible to the camera, as the hull is lying deep in the mud on the seabed: so we cannot rule out that the inaccessible areas of the hull may be damaged. On the other hand, the video recordings show that the vessel is not deformed or damaged in the visible areas of its hull, which could have indicated a weakness in the hull's structural strength. The Accident Investigation Board believes the worst stresses the Langeland's hull was exposed to, occurred in the period after she reported she was listing, i.e. from 04.19 until the loss happened.

Having reported she was listing at 04.19, the Langeland gradually got into waters where the waves were being heaped up, increasing the waves' height and reducing their length. In the final phase before it was lost, we believe the vessel was exposed to the impact of irregular sea, with waves coming from different directions and with different heights and lengths. The total load exposure in this part of the voyage, as

well as the impact when the Langeland sank and the vessel's brutal meeting with the seabed, did not therefore lead to any indications of structural weakness as far as it has been possible to investigate the wreck. The Accident Investigation Board therefore does not consider it very likely that structural weakness could have caused the vessel to list or water to get into the cargo hold, as was reported after a period in which the stresses on the vessel were less than in the final phase. Given that the Langeland was sailing under control and no critical water penetration was reported after 04.19, it is extremely unlikely that any hull damage led to the cargo hold becoming open to the sea.

The Accident Investigation Board has had strength calculations prepared for the Langeland based on condition C02 – Load condition before the vessel was lost, with the excavator aft. These results show that, in this condition, the Langeland had approx. 40% margin in longitudinal strength in relation to the DNV's minimum requirement for still water moment and maximum wave force.

Given that the frames in the 'double skin' under the former main deck had not been checked for 25 years, as this was rendered impossible by the fitting of the steel trimmings in 1984, in spite of the above, the Accident Investigation Board has looked more closely at a scenario in which cracks in the outer skin could have arisen as a result of the frames being weak. Based on the above, we have assumed that this could have led to water getting into the space between the skin and trimmings, possibly in the bottom tank.

The rough estimates the Accident Investigation Board has prepared for water penetration into the 'double skin' on the port side would have led to the Langeland experiencing a heel moment of approx. 268 tm, which would have given a list of approx. 2.5°. Leaking into port bottom tank no. 2 would have resulted in a heel moment of 301.4 tm and a list of approx. 3°. Filling all three bottom tanks on the port side would have resulted in a heel moment of 567.7 tm and a list of approx. 5°. Damage with filling to both the 'double skin' and three bottom tanks would give a list of approx. 7°.

The Accident Investigation Board considers damage to the hull plates that would have led to all these spaces being filled as highly unlikely, and damage that would have filled any of the spaces as not very likely. Filling any of these spaces can be dismissed as the main cause of the list, as neither the individual bottom tanks nor parts of the 'double skin' in themselves produce enough list. It is highly unlikely that the whole 'double skin' was filled, because the hull space was divided into sections by tight frame sections. Filling of some spaces cannot be written off as having partially caused the list, however.

2.6 Considering practice in relation to battening down hatches

The AIBN's investigations of the vessel have shown that the hatches were not battened down. The information the AIBN has later received from the crews on the company's cargo vessels indicate that hatches might not always be battened down properly, so this was not a one-off case for the Langeland on the day of the accident. On the other hand, the company said it was not aware that hatches were not being battened down properly: so there is some distance between what the

company thought and the fact that the hatches on the Langeland were probably not battened down.

The AIBN realize it would be challenging for a shipping company to have sufficient oversight and control of whether its vessels are being operated in accordance with its procedures at all times. This point is also made in the research conducted by Lamvik, Wahl and Buvik (2010). The physical distance between the onshore organisation (company) and ships may make it more likely that practices arise that are out of line with the company's governing documents, even though the company's governing documents are well known. Informal standards develop on how tasks on board are handled 'their way', while the organisation on shore is unaware of this.

The Accident Investigation Board believes it may be correct to use the term 'silent deviation' in this context. On the other hand, silent deviations are often justified by a lack of time, saving work, that procedures are considered unnecessary or difficult to follow, but none of these applies in this specific case. The question the AIBN is thus left with concerning this accident, is why anyone would fail to carry out something which is so evidently critical to safety, especially in bad weather.

The company had procedures for battening down hatches, and the AIBN believes these are adequately described in its management system. From interviews with crew members on the company's vessels, the AIBN considers that these procedures seem to have been both well known and understood. In the course of interviews, the AIBN was given detailed descriptions of departure procedures and how hatches were to be battened down. The AIBN was also given correct descriptions of other procedures from the company's safety management system.

Nor was time pressure a factor in the Langeland's case. However, it takes around 20 min to batten down the hatches, so the practice saves the crew an effort in itself. The company's management has said that the time the hatches should have been battened down was in the middle of the '3 o'clock coffee break': so it is possible they 'forgot' to batten down the hatches. Even so, the AIBN wonders that the hatches were not battened down later when the weather situation changed.

The Accident Investigation Board has been informed that the company recruits only professional seamen. It is also regarded as normal, good seamanship to batten down hatches properly. The AIBN therefore also believes that this was/is something the crew knew had to be done without having to check the procedures. The question, however, is what the term 'good seamanship' involves. Bye and Lamvik (2007) say a pronounced subjective underestimation of risks as against objective risk levels can be a kind of cultural group code in the seamen's culture. In this case, that may mean that the crew did not see battening down hatches as particularly safety-critical.

The Accident Investigation Board's investigations may also indicate that the hatches on the Langeland were damaged, damage which probably did not occur in connection with the loss. The hatches may have been damaged in such a way as to make them difficult to batten down. That may explain why the hatches were not battened down. On the other hand, the damage should have been reported to the company, and the Langeland should not have continued until this had been

rectified. On the other hand, Lamvik, Wahl and Buvik (2010) describe how the seamen's culture prides itself on being able to solve problems on board as they arise without consulting the organisation ashore. The Accident Investigation Board thinks the crew may have been planning to repair the hatches as soon as they had a chance.

In pursuing its investigations, the AIBN has tried to find out why the procedures for battening down hatches may not have been followed. It may seem as if, in the Langeland's case, the reason was that the hatches were damaged and hard to batten down, rather than carelessness or omission. Combined with the information that hatches were not battened down properly on other vessels, this may indicate there is sometimes an attitude of 'she'll be right, mate'.

In conducting these investigations, the Accident Investigation Board has been unable to establish to what extent there was a practice of not battening down the hatches at this shipping company. There are some discrepancies in the information the AIBN has received on this point; also are there no statistics or overviews other than observations from the Coastguard as to the general extent of this in the Norwegian cargo fleet. On the other hand, IACS describes an increasing trend towards reporting damage due to water getting into cargo holds. The classification societies' concerns in connection with this are directed particularly at matters to do with the Load Line Convention and not the destroyed cargo in itself. Based on this information, the AIBN has reason to believe hatches are not being battened down, but cannot say to what extent.

3. CONCLUSIONS

3.1 What happened when the vessel sank

Based on the observations made in connection with the ROV and AUV investigations (how the vessel probably hit the bottom, where the excavator chains and hatch covers / traverse for excavator ended up), the Accident Investigation Board concludes that the vessel did not capsize.

In the last 50 minutes and particularly the last 20 minutes of the Langeland's voyage, the vessel was yawing considerably with veering and possibly a tendency to broaching. The Accident Investigation Board believes that was due to a gradual increase in the forward trim as a result of water and possibly stone gathering in increasing amounts forward in the cargo hold which had been empty after loading the vessel. In high waves of relatively short length, we believe that the Langeland, making around 9 knots, ran the bow into the crest of a wave. The reduced bow height and reserve buoyancy as a result of the forward trim meant that the foreship was not lifted up on the crest of the wave, but was pressed down instead. This led to more water and stone running forward into the formerly empty section of the cargo hold, and the Langeland quickly disappeared below the surface.

3.2 List and possible water in cargo hold

The Langeland's natural periods for both rolling and yawing were very close to the encounter period the vessel had with the waves when these impacted near the beam. This probably meant that the Langeland may have been subject to synchronous rolling and yawing. Water in the cargo hold may also have made the Langeland more liable to synchronous rolling. Major rolling, possibly as a result of synchronous rolling, are believed to have caused the stone in the front of the cargo hold to shift, which is how the list to port arose.

3.3 Trim and stability

The investigation into the loss of the Langeland has discovered that the vessel did not meet two requirements of the Construction Regulations which were normative in terms of the extent of freeboard and reserve buoyancy and positioning of the forward cargo bulkhead. An inaccurate basis for the vessel's original stability calculations and the fact that no trim calculation was prepared meant that the original stability calculations did not provide the guidance as regards reserve buoyancy and positioning of the bulkheads as the regulations intended. The Langeland was built with insufficient reserve buoyancy and with the forward cargo bulkhead too far forward.

The physical modifications made to the Langeland were never followed up by inclining tests or displacement tests and accordingly revised stability calculations, so these design errors were never reassessed.

Whether the loss could have been avoided if the forward cargo bulkhead had been positioned further aft and the vessel had had more reserve buoyancy as the Construction Regulations intended is a matter of speculation; but what has been established beyond any doubt is that the Langeland would have had a significantly greater chance of surviving the sequence of events the Accident Investigation Board has assumed, had these design errors been corrected.

With the sequence of events which the Accident Investigation Board has assumed led up to the loss, there is some probability that the vessel would not have been pushed into the crest of the wave if it had reduced its speed. Due to the possible broaching tendencies, however, it could be argued that it was reasonable to maintain speed and hence the manoeuvrability. Given the experience that may have been gained with synchronised rolling across the waves earlier in the voyage, it may have been natural to maintain speed to avoid the vessel coming with the beam to the waves, especially that close to shore.

The investigation into the loss of the Langeland has discovered, as stated, that the vessel was built with insufficient reserve buoyancy and with the forward cargo bulkhead too far forward. To ensure precise stability calculations that include trim assessment, so that one avoids such design errors in any other cargo ships, the AIBN believes all cargo ships registered with NOR and NIS which do not have calculations prepared using approved software should be required to produce complete new trim and stability documentation. The AIBN will issue a safety recommendation to the Maritime Directorate in this regard.

As the provisions on forward trim / minimum bow height were omitted in the 1987 and 1992 regulations, ships which have been or will be built after 1987 may have

been or will be built with their forward cargo bulkheads too far forwards. The AIBN believes action should be taken to prevent this, and the Accident Investigation Board is therefore of the opinion that the provisions on maximum forward trim / minimum bow height should be reintroduced. The AIBN will issue a safety recommendation to the Maritime Directorate in this regard.

The investigation into the loss of the Langeland has also discovered that the vessel's lightship data had changed considerably since the vessel was built in 1971. Age allowances which are neither known nor corrected for will generally act as an uncertainty factor as far as trim and stability are concerned. This means that a vessel's stability documentation used in making operational assessments will be unreliable. AIBN believes regular inclining or displacement tests should be conducted to discover any age allowance and establish the correct lightship data for cargo ships as is already required for certain passenger ships and fishing vessels. The AIBN will issue a safety recommendation to the Maritime Directorate in this regard.

3.4 Watertight integrity

While sailing northwards through the Kattegat and Skagerrak, the vessel was exposed more or less continuously to sea over deck. The space where the hatch covers were stored during loading and unloading very probably partly filled with water.

The Accident Investigation Board's investigations have discovered that the Langeland's hatches were not properly toggled and hence not seaworthy. Considerable volumes of sea over the deck probably led to the vessel's cargo hold gradually filling with water through the openings between the hatch covers and coaming.

The Accident Investigation Board believes the damage to the rear hatch coaming was already there when the Langeland left Stårnökrossen and started sailing towards Moss. In view of the weather conditions that developed during the voyage and the probability of considerable volumes of water on deck, this damage may have contributed to the vessel's cargo hold filling gradually with water.

3.5 Practice in relation to battening down hatches

The AIBN's investigations of the vessel have shown that the hatches were not battened down. The information the AIBN has received from the crew on other of the company's cargo vessels, indicate that hatches may not be battened down properly at all times, so this was not peculiar to the Langeland on the day of the accident. On the other hand, the company has said it was not aware hatches were not being battened down properly.

The Accident Investigation Board's investigations indicate that the damage to the Langeland's hatch coaming probably did not occur when it was lost. This damage was such that it probably made it difficult to batten down the hatches. That may explain why the hatches were not closed. The Accident Investigation Board thinks the crew may have been planning to repair the hatch coaming as soon as they had a chance.

The shipping company had procedures for battening down hatches, and the AIBN means these are described adequately in the shipping company's management system.

In conducting these investigations, the Accident Investigation Board has been unable to establish to what extent it was common practice not to batten down hatches at this shipping company. There are no statistics or overviews other than observations from the Coastguard on how far this applies in the Norwegian cargo fleet generally. However, IACS describes an increasing trend towards reporting damage on cargo due to water ingress.

The Accident Investigation Board regards battening down hatches as a particularly safety-critical function, as the loss of the Langeland clearly shows. In view of this, the AIBN believes there is a need to increase awareness of the potential risk factors involved in not battening down hatches properly. The AIBN will issue a safety recommendation on this subject.

The Accident Investigation Board also believes shipping companies should focus more on monitoring and checking practice and compliance with safety-critical procedures, including battening down hatches, on their vessels.

4. SAFETY RECOMMENDATIONS

The investigation into this accident at sea has discovered four areas in which the Accident Investigation Board believes it is necessary to propose safety recommendations aimed at improving safety.³

Safety recommendation SEA no. 2012/04T

The Accident Investigation Board's investigations have discovered that the Langeland's stability calculations were imprecise and made without considering its longitudinal trim. That resulted in the vessel being built without enough reserve buoyancy and with the forward cargo bulkhead positioned too far forward, thus significantly reducing the vessel's ability to survive in terms of withstanding considerable cargo shifting along the length of the ship.

The Accident Investigation Board Norway advises the Maritime Directorate, to instruct ships which have not had calculations prepared with approved software, to provide a full new set of trim and stability documentation.

Safety recommendation SEA no. 2012/05T

At the time the Langeland was built (in 1971), there were provisions on maximum forward trim / minimum bow height under theoretical full load conditions with a homogenous load, but there are no such requirements in the current cargo ship regulations. This means that vessels built/being built since these provisions were removed (in 1987) may have been or will be designed with design errors corresponding to the errors on the Langeland.

³ This investigation report is submitted to the Ministry of Trade and Industry, which will take the action required to ensure these safety recommendations are duly noted.

The Accident Investigation Board Norway advises the Maritime Directorate to reintroduce the provisions for cargo ships relating to maximum forward trim / minimum bow height for load conditions with homogenous load.

Safety recommendation SEA no. 2012/06T

The investigation into the loss of the Langeland shows that the vessel's lightship data had changed considerably since the vessel was built (in 1971), known as the 'age allowance', and that no inclining or displacement tests had been conducted that might have revealed this. This meant that the vessel's stability documentation which was used for preparing operational assessments was unreliable.

The Accident Investigation Board Norway advises the Maritime Directorate to introduce provisions for regular inclining or displacement tests for cargo ships in line with the provisions which already exist for certain passenger ships and fishing vessels.

Safety recommendation SEA no. 2012/07T

The loss of the Langeland shows that securing hatches is especially safety-critical. The AIBN has reason to believe that hatches are not battened down properly on many vessels, but is unable to establish how common this practice is at the shipping company in question or in the Norwegian cargo fleet generally.

The Accident Investigation Board Norway would advise the Maritime Directorate to take steps to increase awareness of the risk factors that may be involved in not securing hatches properly.

Accident Investigation Board Norway

Lillestrøm, 5 June 2012

ANNEXES

Annexe A: FFI report

Annexe B: Historical details of vessel's hull, stability and load line

Annexe C: Details of weather and wave conditions and their effects on the vessel

Annexe D: Schematic modelling of hull to calculate forces

Annexe E: Beaufort scale and wave conditions

Annexe F: Operational Oceanographics

Annexe G: Weather and sea conditions on the Langeland's last voyage

Annexe H: Wave data

Annexe I: Graphs showing heading, COG and SOG

Annexe J: Stability calculations

Annexe K: References

Resultater fra HUGIN HUS-operasjon ved MV Langeland

Martin Syre Wiig

Forsvarets forskningsinstitutt/Norwegian Defence Research Establishment (FFI)

17. august 2011

FFI-notat

3749

Emneord

AUV

HUGIN

HISAS

HUGIN 1000 HUS

Godkjent av

Petter Lågstad

Prosjektleder

Nils Jacob Størkersen

Forskningsjef

Jan Erik Torp

Avdelingssjef

Sammendrag

Den 31.juli 2009 forliste lasteskipet MV Langeland i Kosterfjorden i Sverige. Som en del av undersøkelsene til Statens havarikommisjon for transport deltok FFI med sin autonome undervannsfarkost HUGIN HUS og personell i en undersøkelse av området rundt vraket den 30.mai 2011. Formålet var å kartlegge området rundt vraket for å finne noe som kunne bidra til å forklare hendelsesforløpet. Særlig fokus var på å finne en gravemaskin montert på skipet samt lasteluker ROV undersøkelser ikke hadde gjort rede for.

Kongsberg Maritimes testfartøy Simrad Echo var leid inn som moderfartøy under operasjonen. Denne er blant annet utstyrt med et multistråle-ekkolodd som ble brukt til å lage et bunnkart over området. Bunnkartet dannet grunnlaget for detaljplanleggingen av HUGIN-dykket. Posisjonen på vraket ble bekreftet med ekkoloddet, og det ble observert en mulig kandidat for den savnede gravemaskinen.

Hovedproduktet fra operasjonen er sonarbilder fra HUGIN HUS. Vraket ble passert flere ganger og det ble observert interessant vrakgods i området rundt. Noe av dette kan være lasteluker. Det ble ikke observert noe som åpenbart var gravemaskinen og objektet observert med ekkoloddet ble avkreftet som kandidat.

English summary

On July 31st 2009 the cargo vessel MV Langeland sank in the Koster fjord in Swedish coastal waters. FFI participated in the investigation performed by the Accident investigation board Norway by providing a HUGIN vessel and personnel in an operation on May 30th 2011. The purpose of the investigation was to survey the area around the wreck, looking especially for debris that might help to explain the chain of events. Special attention was paid to find a missing excavator and hatches from the wreck.

A test vessel belonging to Kongsberg Maritime, Simrad Echo, was hired for the operation. Simrad Echo is equipped with a multibeam echosounder which was used to create a map of the sea floor in the operational area. The map constituted the foundation for detailed mission planning for the HUGIN operation. The position of the wreck was confirmed by the echosounder, and an object that might be the missing excavator was identified.

The main product of the operation is sonar images from HUGIN. The wreck was passed from several directions, and interesting debris was observed in the immediate area around the wreck. Some of this debris might be hatches, however no contact was observed that was immediately recognizable as the excavator.

Innhold

1	Innledning	6
2	Gjennomgang av HUGIN-dykket	7
2.1	Planlegging av dykket	7
2.2	Gjennomføring	8
3	Resultater	9
3.1	MV Langeland	9
3.2	Skred	12
3.3	Interessante objekter	13
3.4	Objekt observert med EM710	17
3.5	Andre vrakrester	18
3.6	Liten båt	19
4	Diskusjon	20
4.1	MV Langeland	20
4.2	Objekt L1 til L3	20
4.3	Andre objekter	20

1 Innledning

Den 31.juli 2009 forliste lasteskipet MV Langeland i Kosterfjorden i Sverige. Skipet var lastet med pukk, og holdt en nordlig kurs da ulykken skjedde.

Statens havarikommisjon for transport (SHT) har undersøkt vraket med ROV[1], men flere spørsmål gjenstår. Blant annet ble en gravemaskin MV Langeland var utstyrt med ikke lokalisert. Det samme gjaldt en del av skipets lasteluger. SHT ønsket å bruke HUGIN til å undersøke området rundt vraket for å se om gravemaskinen og noen av lastelukene kunne lokaliseres.

Petter Lågstad, Christian Jørgensen og Martin Syre Wiig fra FFI deltok den 30.05.2011 med FFIs HUGIN-farkost (HUGIN HUS) på dette oppdraget. Fra SHT deltok Elisabeth Juel Ramos og Bjørn Bratfoss. Fra den svenske søsterorganisasjonen deltok Ylva Bexell. Kongsberg Maritimes testfartøy, Simrad Echo, var leid inn som moderfartøy med skipper Geir Øyen.

Simrad Echo er utstyrt med et multistråle-ekkolodd, EM710, som ble brukt til å skaffe et kart over operasjonsområdet samt til å bekrefte vrakets nøyaktige posisjon. KM hadde på eget initiativ sendt med en operatør til EM710. I tillegg var Stig Råen fra AUV-avdelingen ved KM med som støtte for FFIs operatører, samt til å være ansvarlig for integreringen av HUGIN HUS med Simrad Echo.

Hovedproduktet fra denne operasjonen er sonarbilder generert med HUGINs syntetisk aperture sonar (SAS), en HISAS 1030[2]. Rådata tatt opp av HUGIN er etterprosessert på FFI med FOCUS Toolbox[3], et verktøy for generering av SAS-bilder. Bildene er presentert i Kapittel 3

Både HISAS og EM710 kan generere detaljerte batymetriske kart over havbunn. Disse er brukt i planleggingen av toktet, og i evalueringen av sonardata, men er ikke tatt med i dette notatet etter krav fra svenske myndigheter.

2 Gjennomgang av HUGIN-dykket

2.1 Planlegging av dykket

Operasjonen ble gjennomført mandag 30.05.2011, av diverse årsaker den eneste dagen det var mulig å gjennomføre. Et utkast til toktplan var lagd på forhånd ut i fra posisjonen til MV Langeland tidligere observert av Havarikommisjonen. Denne posisjonen ble bekreftet med multistråle-ekkoloddet EM710 om bord på Simrad Echo på operasjonsdagen. Endepunktene er angitt som to hvite kors i Figur 2.1.

Hugindykket ble planlagt for å dekke området rundt vraket, med spesielt fokus på området sydvest for vraket. Motivasjonen var at dersom gravemaskinen eller annet utstyr hadde falt av på et tidspunkt før forliset, ville det ligge i dette området siden MV Langeland hadde en nordlig kurs før den sank. Det ble lagt inn noen kryssende linjer rundt vraket for ekstra god dekning av nærområdet.

På EM710 ble det observert et objekt 250m 190° for vraket. Objektet var av samme størrelsesorden som gravemaskinen, og to kryssende toktlinjer ble derfor lagd rundt dette også.



Figur 2.1: Toktplan for dykket

2.2 Gjennomføring

Mye vind medførte at dykket måtte utsettes noen timer, slik at tilgjengelig tid ble redusert. I tillegg medførte vinden operasjonelle utfordringer ved sjøsetting og opptak, samt sjøsyke hos flere av deltakerne. Med unntak av noen tekniske utfordringer som følge av dette, var operasjonen vellykket.

Underveis i dykket ble det besluttet å kutte de to østligste toktlinjene av sikkerhetsmessige grunner, da disse viste seg å gå for langt inn på grunt område og i nærheten av utsatte fiskebruk. Etter den sjette linjen ble HUGIN følgelig kommandert til å hoppe til krysslinjene.

HUGIN ble sjøsatt kl. 15:35 og tatt opp kl. 17:45. Toktdata ble kopiert fra farkosten og over på eksterne harddisker. Dataene ble delvis etterprosessert på tilbaketuren og ferdig etterprosessert på FFI Kjeller. Hovedproduktet fra dette dykket er bilder fra HUGINs syntetisk aperture sonar (SAS), presentert i kapittel 3.

En feil på farkosten ble, grunnet sjøsyke, ikke oppdaget underveis i dykket. Sonardataene ble derfor dårligere enn forventet i områder med mye batymetri, slik som i området rundt vraket.

3 Resultater

Dette kapitlet inneholder sonarbilder av MV Langeland samt interessante objekter observert i området rundt. Rådataene tatt opp av HUGIN er etterprosessert i FOCUS Toolbox, et verktøy utviklet av FFI for etterprosessering av SAS-data.

Som nevnt i kapittel 2.2 ble datakvaliteten på områder med mye batymetri redusert grunnet en oversett feil på farkosten. Dette gjør blant annet at bildene i området rundt vraket er noe mindre fokusert enn det som er optimalt, samt at sterke reflektorer blir dratt ut i bildet.

3.1 MV Langeland

Det ble foretatt flere plasseringer av MV Langeland. Figur 3.1 til Figur 3.4 viser passeringer av vraket fra fire sider. Sonarbildene antyder at baugen på skipet er begravd i havbunnen, mens akterenden stikker opp. I forkant av vraket, rundt området hvor baugen er begravd, kan det observeres flere vrakrester samt et stort område med tydelig forstyrret bunn. Høydekurvene er ikke tegnet inn her, men terrenget rundt vraket er generelt fallende fra sydøst mot nordøst. Terrenget heller med en vinkel på omtrent 13° .

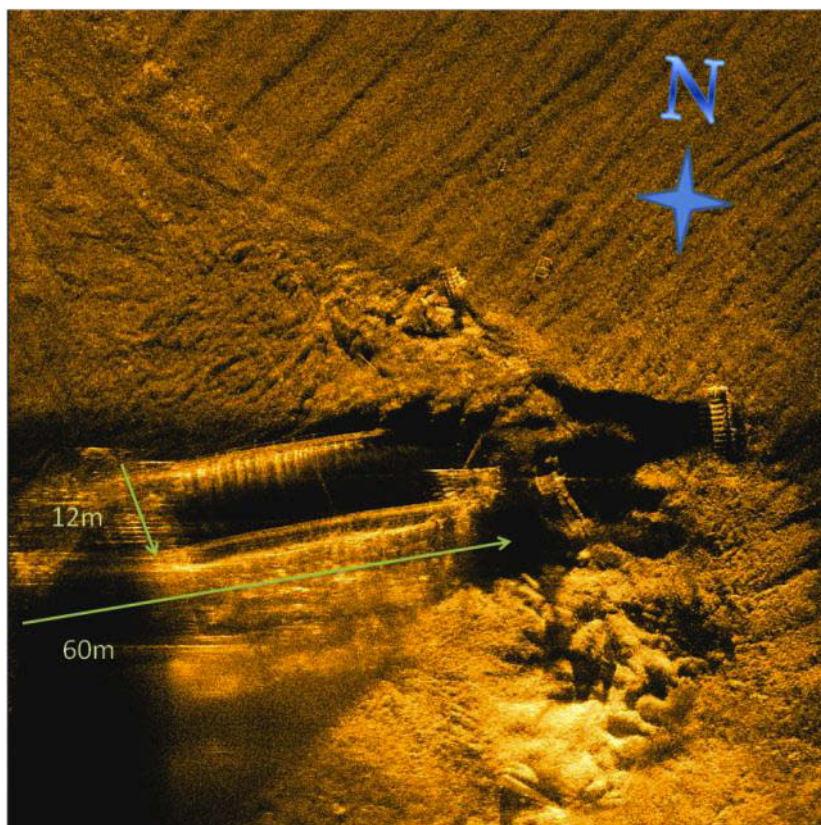

Figur 3.1: MV Langeland Bildet er tatt fra nord.

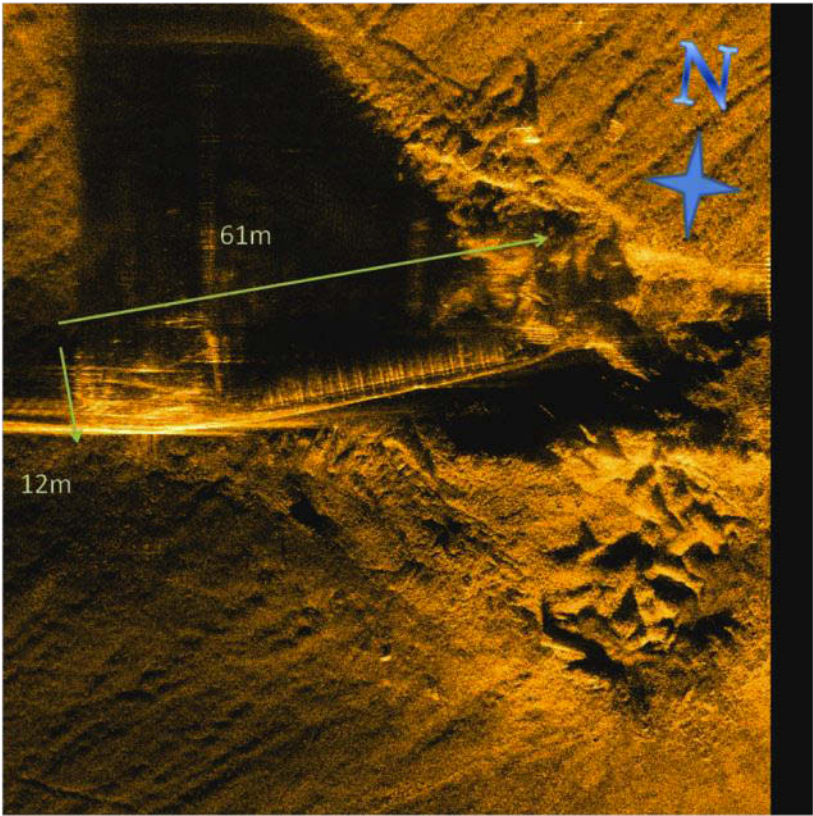

Figur 3.2: MV Langeland. Bildet er tatt fra syd.

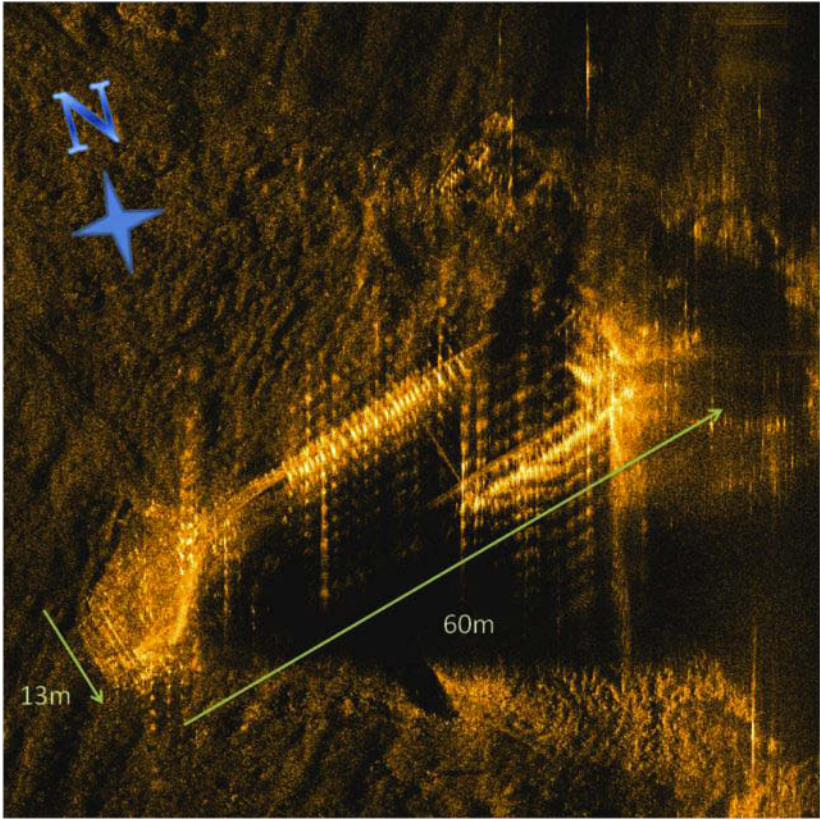

Figur 3.3: MV Langeland. Bildet er tatt fra vest.

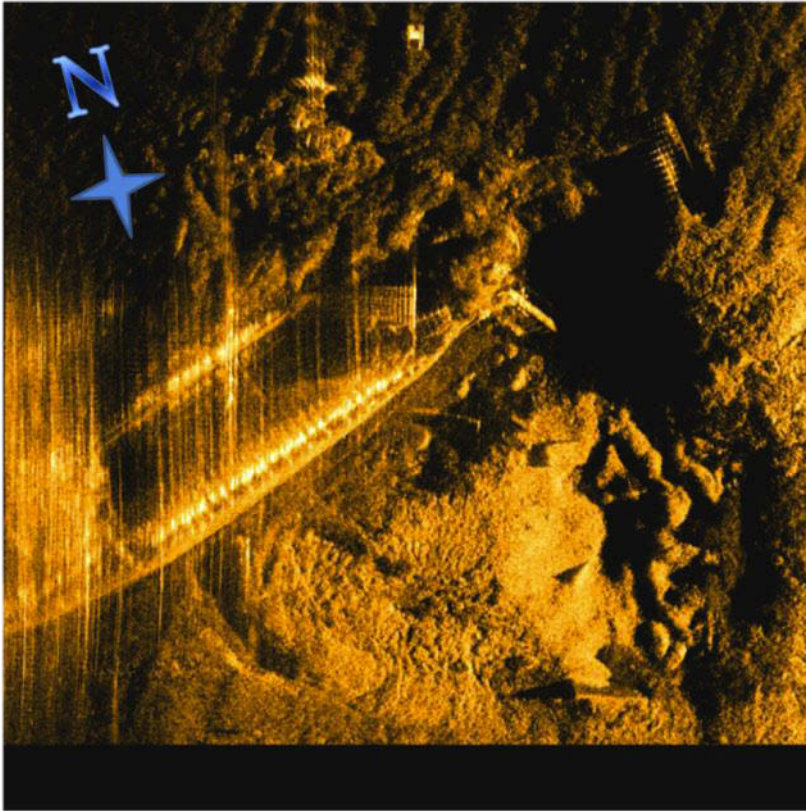

Figur 3.4: MV Langeland, 80x80m bilde. Bildet er tatt fra øst.

3.2 Skred

I retning 317° (ned skråningen vraket ligger i) fra vraket strekker det seg et omtrent 180m langt skred som er vist i Figur 3.5.

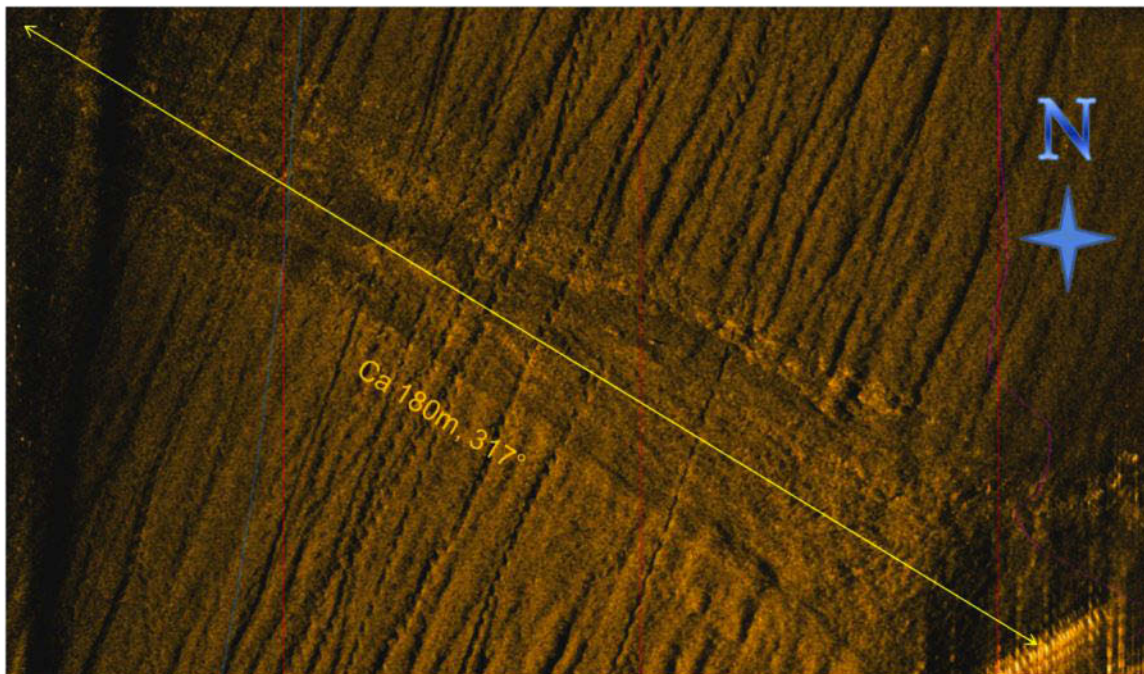

Figur 3.5: Skred ved vraket, ca 180m langt.

3.3 Interessante objekter

I området rundt fremre del av vraket er det observert 3 objekter som kan være lasteluker. Disse objektene er navngitt L1, L2 og L3 og er vist i Figur 3.6 til Figur 3.12. Plasseringen av disse i forhold til vraket er vist i Figur 3.13.

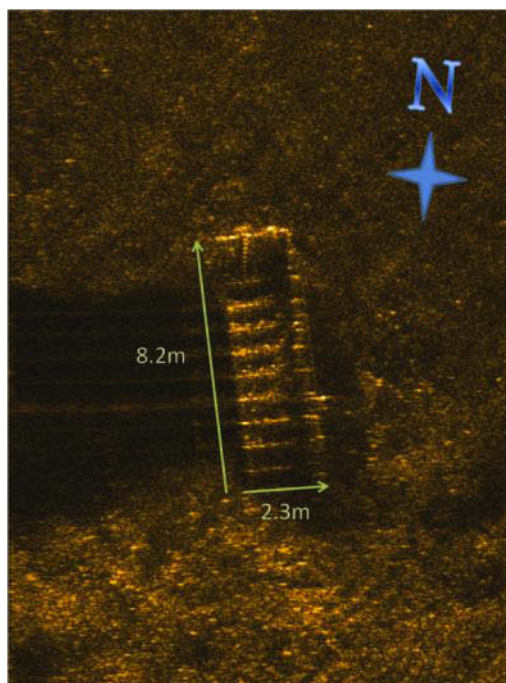

Figur 3.6: Objekt L1. Bildet er tatt fra nord.

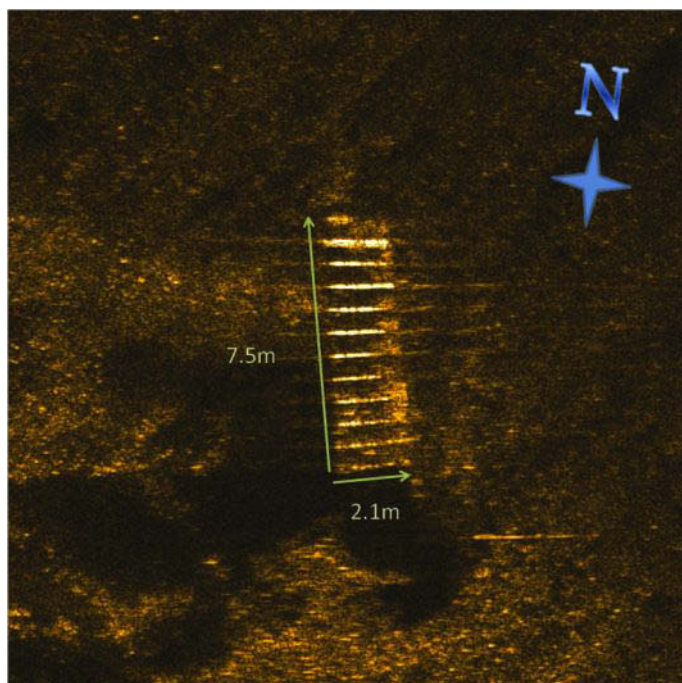

Figur 3.7: Objekt L1. Bildet er tatt fra sør.

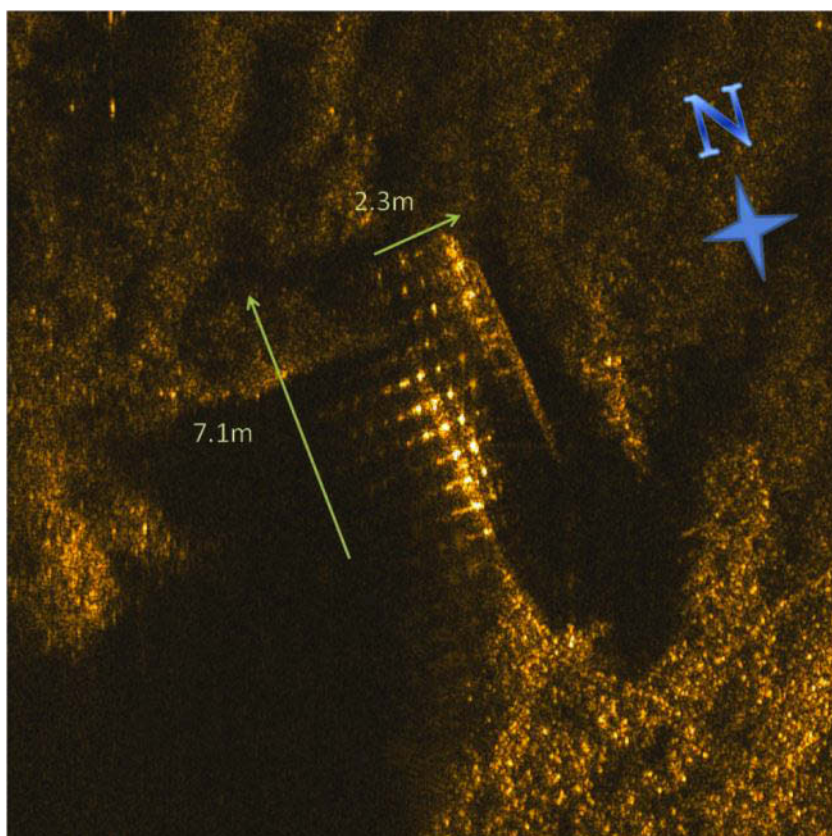

Figur 3.8: Objekt L1. Bildet er tatt fra øst.

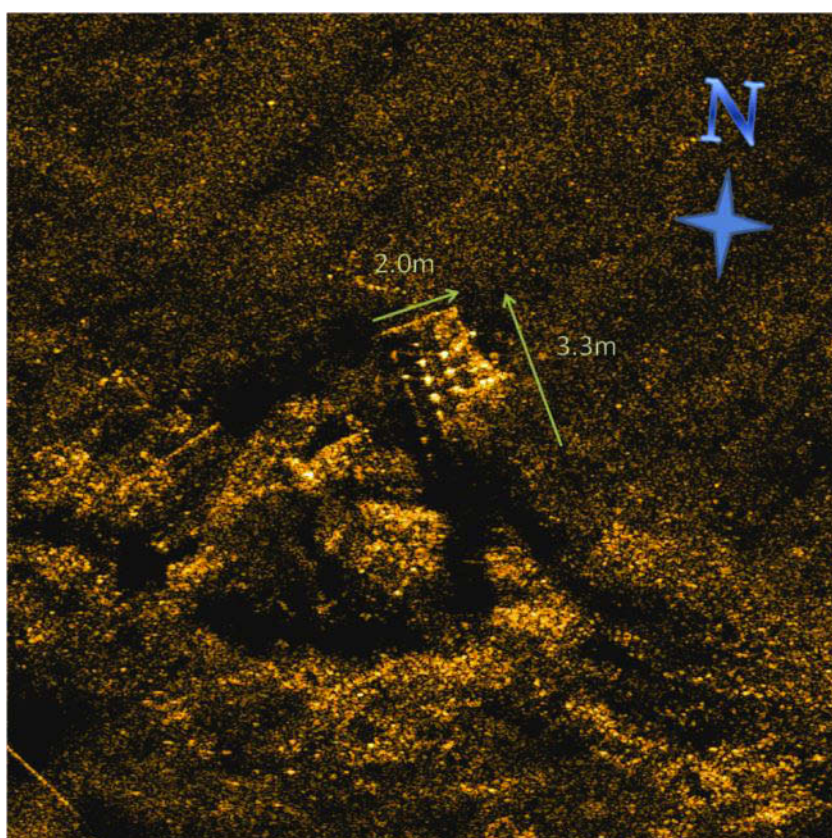

Figur 3.9: Objekt L2. Bildet er tatt fra nord.

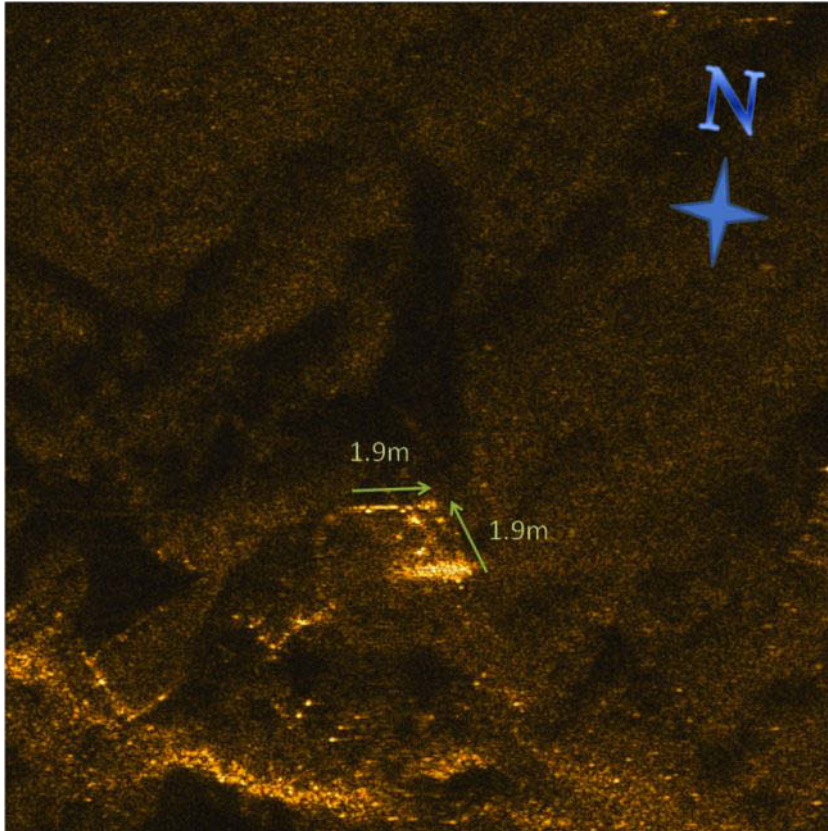

Figur 3.10: Objekt L2. Bildet er tatt fra sør. Objektets akustiske skygge antyder at det stikker omtrent 1m opp fra bunn.

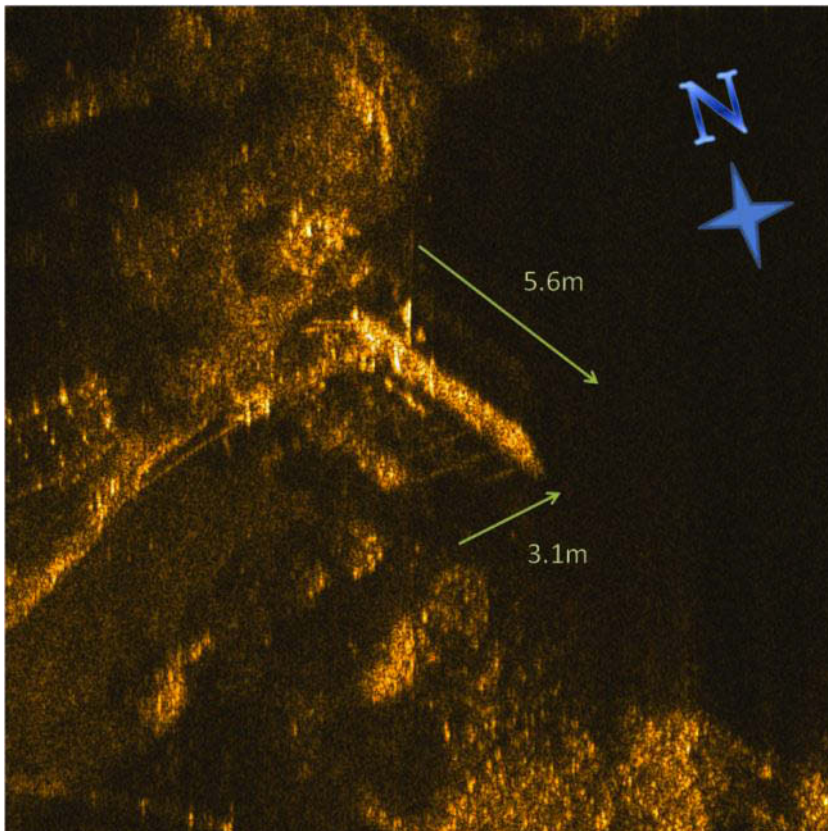

Figur 3.11: Objekt L3. Bildet er tatt fra øst.

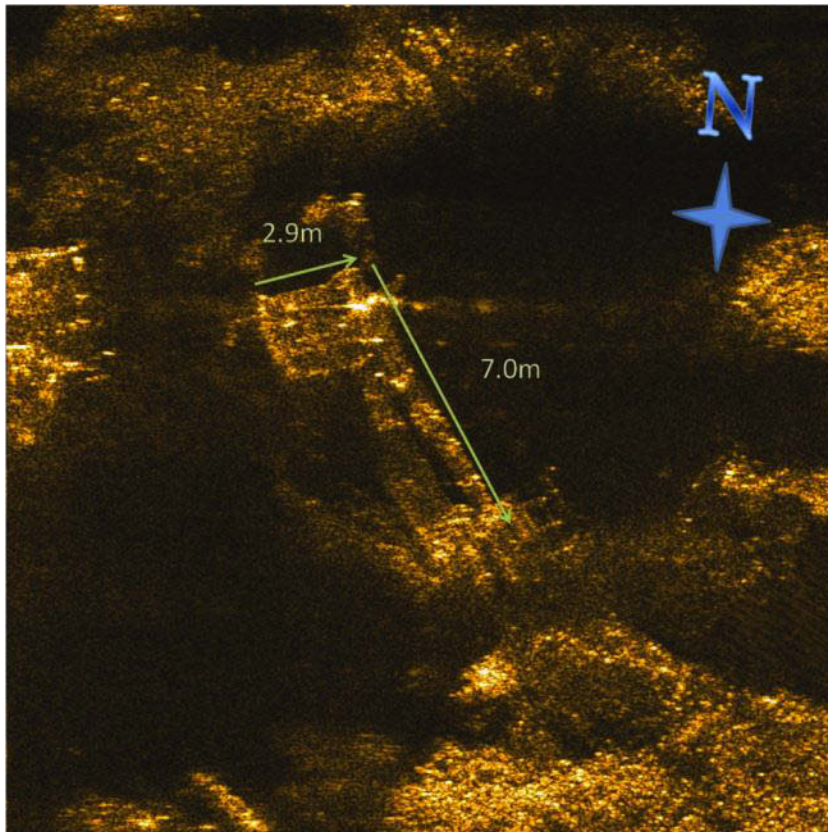

Figur 3.12: Objekt L3, 20x20m. Bildet er tatt fra nord.

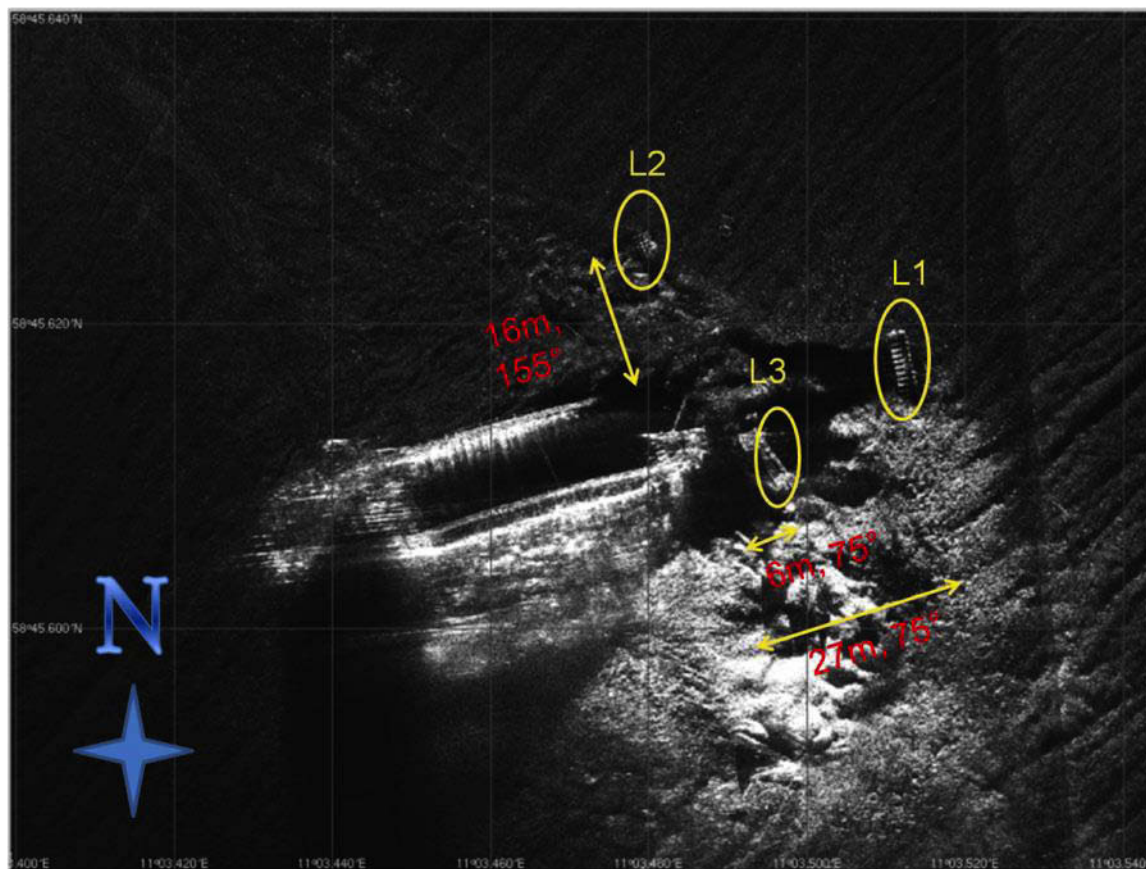

Figur 3.13: Objekt L1, L2 og L3 i forhold til vraket.

3.4 Objekt observert med EM710

Det ble observert et objekt som kunne være gravemaskinen med EM710 om bord i Simrad Echo. Dette objektet er navngitt O1 og ble passert flere ganger, vist i Figur 3.14.

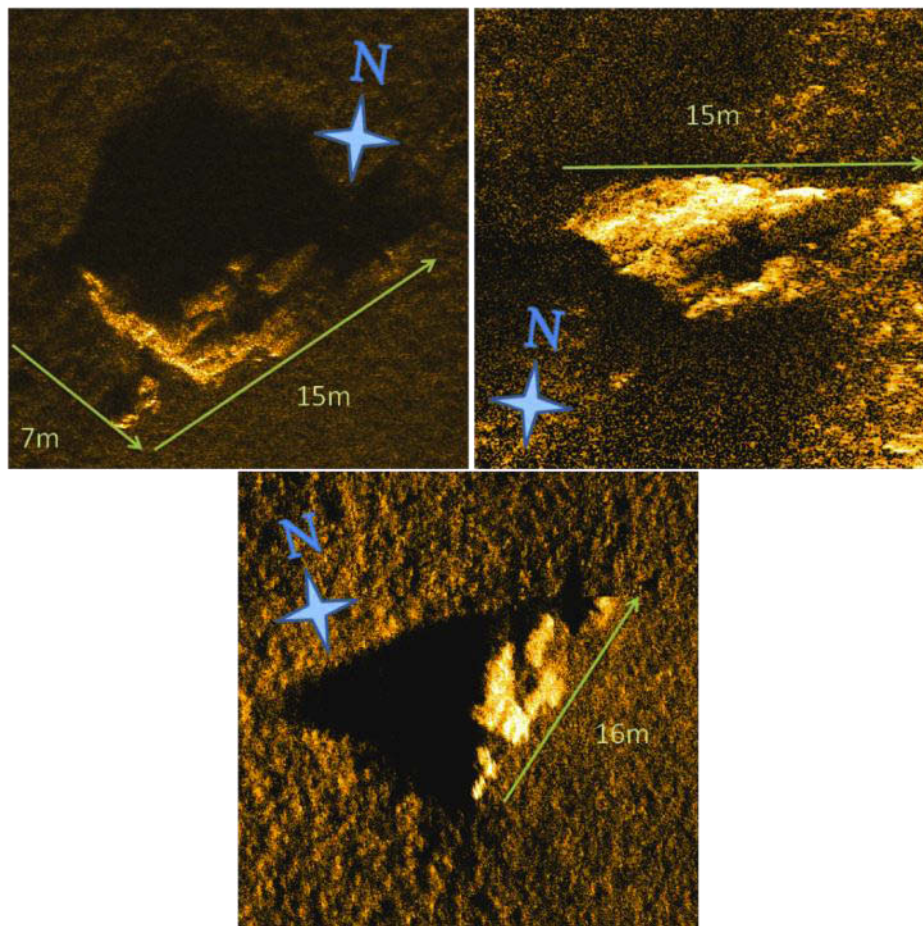

Figur 3.14: Objekt O1. Fra øverst til venstre og med klokka er bildene tatt fra sør, nord og øst i forhold til objektet.

3.5 Andre vrakrester

Andre mulige vrakrester, navngitt V1 til V4, er også funnet i nærområdet til vraket. Sonarbilder av objektene vises i Figur 3.15 til Figur 3.17.

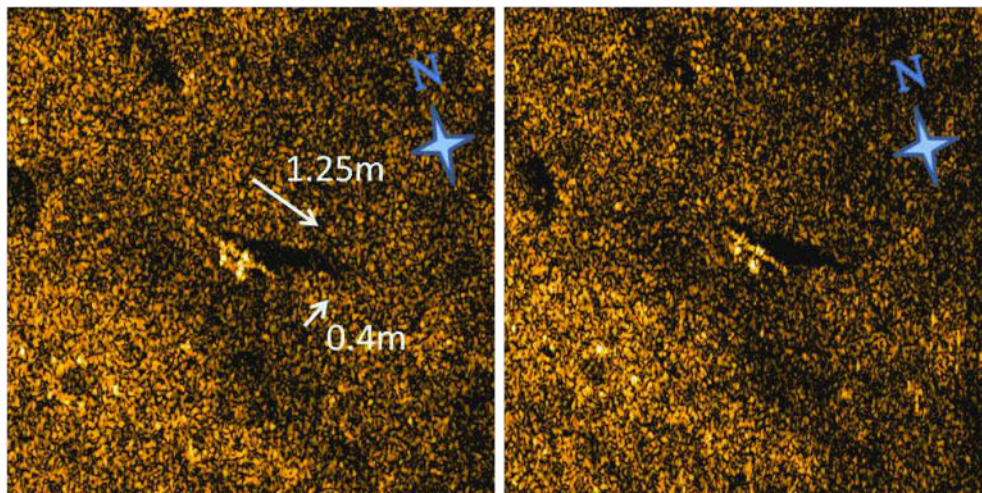

Figur 3.15 Objekt V1. Bildene er tatt fra vest i forhold til objektet.

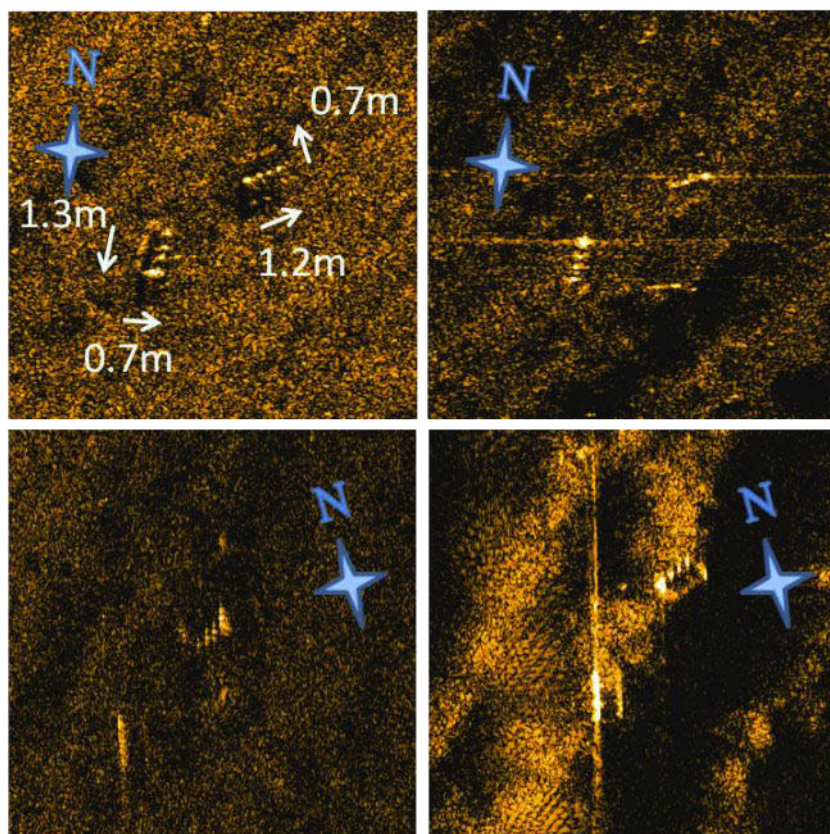

Figur 3.16 Objekt V2 og V3. Fra øverst til venstre og med klokka er bildene tatt fra nord, sør, øst og vest i forhold til objektene.

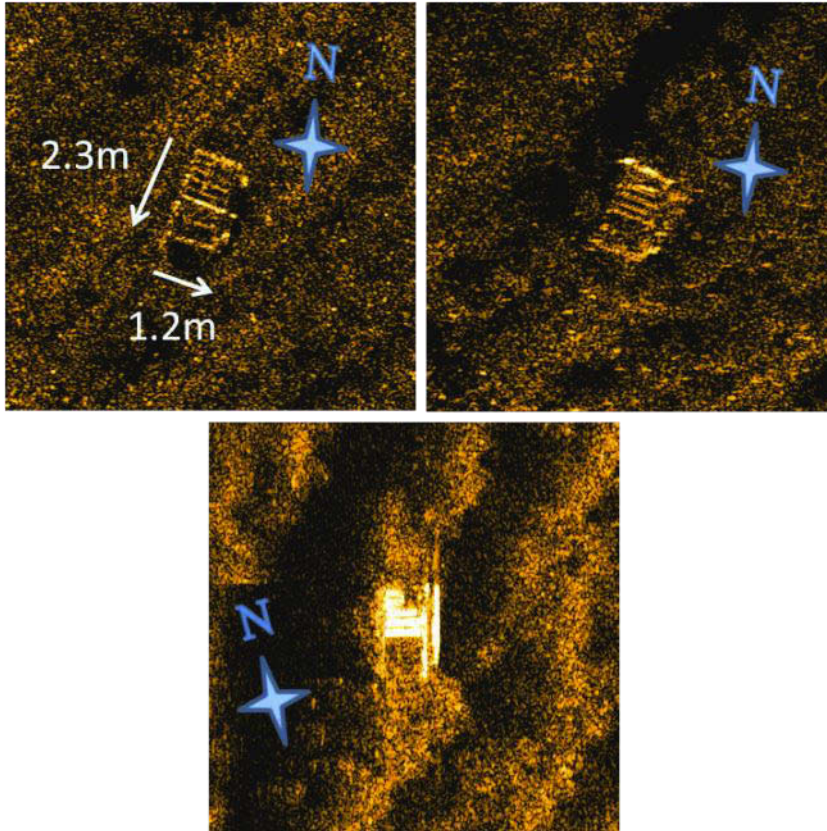

Figur 3.17 Objekt V4. Fra øverst til venstre og med klokka er bildene tatt fra nord, sør og øst i forhold til objektet.

3.6 Liten båt

Ved posisjon 58°45.221N, 11°03.159E ble det observert et lite vrak med dimensjoner 7.8m x 2.9m. Dette er 780m i retning 200° for MV Langeland. Båten er vist i Figur 3.18.

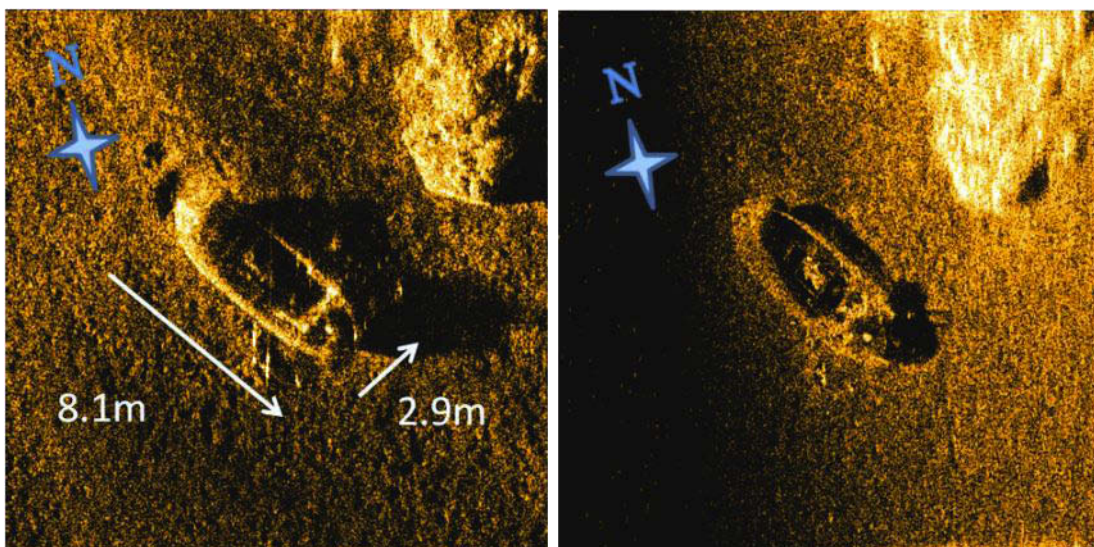

Figur 3.18 Lite vrak observert syd for MV Langeland. Bildene er tatt fra vest.

4 Diskusjon

Dette kapitlet inneholder en diskusjon og noen vurderinger av resultatene presentert i Kapittel 3. Vurderinger av vrakets egenskaper og oppførsel er utenfor fagfeltet til forfatteren, og må leses som forslag og alternativer.

4.1 MV Langeland

Baugen til MV Langeland (Figur 3.1 til Figur 3.4) er begravd og akterenden stikker en del meter opp (målingene er upresise på hvor mange). Dette kan tyde på at vraket har truffet bunn med en del kraft med baugen først. Det store området med forstyrrede sedimenter rundt vraket kan underbygge dette.

Området med skadet havbunn er betydelig mer utpreget på sørøstsiden av vraket, altså ovenfor i terrenget. Dette kan tyde på flere ting, blant annet at:

- Av de sedimentene som ble virvlet opp da vraket traff bunn, dannet de på nedsiden skredet vist i Figur 3.5, mens de på oppsiden la seg i nærområdet til vraket.
- Vraket har enten sklidd eller svingt seg etter nedslaget. Siden baugen er begravd virker det her mer sannsynlig at vraket har svingt seg om baugen enn at det har sklidd.

4.2 Objekt L1 til L3

Objekt L1 til L3 har dimensjoner og konturer som gjør at de kan ligne på hele eller deler av lasteluker. Objekt L1 (Figur 3.6 til Figur 3.8) virker mest lovende, da dette kan se ut som en hel lasteluke i full lengde. Objekt L2 (Figur 3.9 og Figur 3.10) er for lite til å være en hel lasteluke, men har omtrent riktig bredde. Dette kan være en lasteluke som er delvis begravd og stikker litt opp. Det er ikke mulig å skille på bildet om det er et delvis begravd større objekt eller et mindre objekt som er synlig i sin helhet.

Objekt L3 (Figur 3.11 og Figur 3.12) har en smal sydlig del og en større nordlig del. Dette er særlig synlig i Figur 3.12 og Figur 3.9. Dette kan tyde på at det ikke er en lasteluke.

4.3 Andre objekter

Objekt O1 (Figur 3.14), som på EM710 kunne se ut som et objekt med riktige dimensjoner til en gravemaskin, har ingen skarpe kanter og en jevn skygge. Dette tyder på at det er et naturlig objekt, for eksempel en steinhaug, og ikke et nytt og menneskeskapt objekt.

Det lille vraket observert 780m sør for MV Langeland (Figur 3.18) er mest sannsynlig en fiskebåt eller tilsvarende farkost, og er antatt ikke relatert til MV Langelands forlis.

Referanser

- [1] Statens havarikommisjon for transport, "Pågående undersøkelse - Langeland," <http://www.aibn.no/Sjofart/Rapporter/09-534>, 2011.
- [2] P. E. Hagen, T. Fossum, and R. E. Hansen, "HISAS 1030: The next generation mine hunting sonar for AUVs," 2008.
- [3] R. E. Hansen, H. J. Callow, T. O. Sæbø, and S. A. Synnes, "Focus users guide v4.0.," FFI, 2009.

ANNEXE B

HISTORICAL DETAILS OF THE VESSEL'S HULL, STABILITY AND LOAD LINE

Load line (draught) and tonnage history:

The Langeland was delivered from the yard as an open shelter decker, that is, the main deck which divided the cargo hold into an upper and lower hold was the freeboard deck, and it was the surface of this deck that was the baseline for the maximum draught in salt water. The surface of the main deck was 3.898 m above the keel. The international and domestic load line certificates stated the freeboard from the upper deck, the shelter deck, which was equivalent to summer draughts of 3.846 m and 3.871 m. Domestic freeboard was based on an equivalent deck, using an imaginary deck height where the height above the keel appeared to be the average height of the different steps in the actual main deck. This 'lifted' the deck before the draught was established as a table freeboard less the depth to the imaginary deck.

As an open shelter decker did not have the upper deck as a freeboard deck, and thus had limited draught, the gross tonnage was also low. The volume of the cargo hold, engine room, store room, etc. above the main deck was not included. The Langeland's first tonnage certificate gave its tonnage as 499.85 reg. tons, so the vessel was what was known as a 'paragrafbåt' ('statutory ship', ship with design adapted to statutory and regulatory requirements - translator). The volumes included were measured to the inside of the wooden dunnage in the sides and on the tank top in the cargo hold. To indicate that the Langeland was an open shelter decker, with large volumes which were not included in the gross tonnage, so-called tonnage triangles were marked close to the load marks on both sides of the ship. These triangles were applied with their points down on the same vertical level as the top load line boundary, in this case domestic fresh water (summer).

In the autumn of 1972, Det norske Veritas issued load line certificates as closed shelter decker: that is, that the shelter deck was the freeboard deck where the surface was 6.458 m above the keel. International and domestic load line certificates show the freeboard from the shelter deck which was equivalent to the summer draught at 5.400 m and 5.625 m respectively. A new tonnage certificate as a closed shelter decker with a gross tonnage of 1200.89 reg. tons was issued during the same period. When the vessel was 'closed', some rearrangements were made for some spaces, the side dunnage in the cargo hold and the cargo hatches on the main deck were removed.

The Norwegian Maritime Directorate's letter to I/S Janneland Anders Stokkas Rederi A/S of 3 August 1977 issues a permit until further notice that the vessel (then the Janneland) can be loaded down in accordance with the then current rules on load lines for ships on domestic routes when used on the Swedish coast. The Directorate points out that this permit applies to voyages between Swedish ports and not international voyages or parts thereof, and that it is conditional on the approval of the Swedish authorities and the classification society.

The Swedish Maritime Administration's letter to I/S Janneland Anders Stokkas Rederi A/S of 22 September 1977 allows loading down to domestic freeboard on voyages between Swedish ports, provided the vessel is within 15 nm of port or skerries where they can find shelter if necessary. This permit does not apply between mainland Sweden and Gotland or between destinations outside Sweden and Swedish ports. The Swedish Maritime Administration notes that both the DNV and Norwegian Maritime Directorate allowed loading down to domestic freeboard in Swedish waters.

Mikkal Myklebusthaug became the owner of the vessel on 12 May 1982, and the Langeland was issued with a new tonnage certificate as a combined open and closed shelter decker. Such tonnage certificates contained two sets of gross and net tonnages. The load marks were positioned in relation to the shelter deck as the freeboard deck: that is to say, the vessel was closed in the load line sense. The tonnage triangles were located on the ship sides with their lower points on a vertical level corresponding to the former 'open' draught for domestic shipping, 3.871 m. If the whole triangle could be seen above the loaded waterline, the lowest set of gross and net tonnages in the tonnage certificate applied. If some or all the triangle was below the loaded waterline, the highest tonnages applied. With this tonnage certificate, the Langeland had deeper loading down as an open shelter decker in international shipping than the vessel had had as a purely open shelter decker, the gross tonnage as 'open' and 'closed' being 527.23 and 1208.72 reg. tons respectively. The reason for the increase in both gross tonnages was the reassignment of some spaces and that the bottom dunnage in the cargo hold had been taken out in 1974 and replaced with thinner dunnage.

Calculations under the then regulations on where the tonnage triangle should be positioned for combined open and closed shelter deckers usually gave less draught as 'open' than the draught would have been purely as an open shelter decker. Because of this change, a number of vessels switched from sailing as purely open and closed shelter deckers when carrying light and heavy cargoes respectively: so the tonnage certificates and load line certificates could be changed any number of times in a year. The load marks and tonnage triangles also had to be painted on or painted over each time a vessel changed its tonnage certificate and load line certificate. The fact that the Langeland was given the tonnage triangle for the combined tonnage certificate at a height corresponding to the former domestic freeboard for an open shelter decker which was also based on an equivalent deck, was a special competitive advantage.

The Langeland was issued with a new tonnage certificate on 10 June 1982. The vessel was measured down with a wooden dunnage at least 76 mm thick being laid on the sides and bottom of the cargo hold. The dunnage thickness of 76 mm or $\frac{1}{4}$ foot was the maximum that could be deducted when calculating the hull volume for tonnage purposes. A cabin and a provision store were also converted to deck stores. The deck store room over the main deck was not included in the gross tonnage, while the cabins and provision stores room were spaces that had to be included. The new gross tonnage as an open and closed shelter decker in the new combined tonnage certificate was 499.85 and 1181.48 reg. tons respectively. The draught to the tonnage triangle was unchanged at 3.871 m.

When the Langeland returned to the Norwegian register after her period under the Danish flag, the new tonnage certificate, issued 31 October 1990, was identical to that of 10 June 1982,.

The International convention on measurement of ships of 1969 was applied to existing vessels on 18 July 1994. The Langeland was issued with a tonnage certificate under the new convention on 26 October 1994. Under the new convention, the entire enclosed volume in a vessel must be included in the gross tonnage, so the vessel's draught then only affects the net tonnage. The gross tonnage under the new rules is a unitless entity, so the register ton of 100 ft³ or 2.83 m³ was thus history. The Langeland's 1969 tonnage certificate gave its gross tonnage as 1591.

As many ships had their gross tonnage increased relatively considerably when switching to the 1969 convention, the IMO issued guidelines which stated that the former gross tonnage could be included in the test certificate as a supplementary tonnage, called the safety tonnage or national tonnage. The intention was that this safety tonnage would be used as the vessel's parameter under the safety-related rules if no individual laws or regulations stated otherwise. The safety tonnage applies as long as the vessel is not modified or converted in such a way to change the safety tonnage or international gross tonnage by more than 1%. The Langeland's last tonnage certificate from 1994 stated the former gross tonnage as a closed shelter decker, 1181.48, as its safety tonnage.

Permission to load down to domestic freeboard in Swedish waters

As stated above, the Swedish Maritime Administration gave Anders Stokkas Rederi A/S permission to load down to domestic freeboard for the Langeland (then the Janneland) sailing between Swedish ports.

When the Bureau Veritas' classification period expired in 1994, the Langeland was required to remove the national load markings. The demand to remove the markings must originally have come from the Norwegian Maritime Directorate due to the vessel's transfer to NIS, which meant the ship could no longer carry cargoes between Norwegian ports and so did not need the domestic load line any longer.

In 1996, Mikkal Myklebusthaug Rederi applied to the Maritime Directorate for permission to maintain the national load marks for the Langeland. The application stated that the vessel had been under contract to Elkem carrying stone from Karlshamn to Moss for the last 20 years, and that it was very important for the shipping company to avoid the reduction in cargo capacity that the removal of national load markings would entail. They therefore applied for permission to maintain the national load markings in NIS in order to use the Swedish dispensation.

The Norwegian Maritime Directorate pointed out that they could not see any grounds for assigning national freeboard for use in Swedish waters only, as such freeboard could only be issued to vessels sailing short coastal journeys or less, for carrying cargo between Norwegian ports.

The shipping company's lawyer then appealed the Maritime Directorate's ruling to the Ministry of Foreign Affairs. The Maritime Directorate told the Ministry that, under the Public Administration Act relating to appeal case processing, they had considered the shipping company's appeal, but could not see any reason to revise their decision.

The Ministry then informed the shipping company's lawyer that the appeal had been upheld and the Maritime Directorate's ruling had been overturned. The Ministry pointed out that this case was about maintaining a load mark the ship already had, and not about issuing national load marks for a new NIS ship which did not have national load marks already. The Ministry also stated that they could not see that it was the case automatically that national load marks should be removed when reregistering from NOR to NIS. As the ship had not changed its sailing area or use under the dispensations given, the Ministry could not see there were any particular grounds why the load marks should be removed.

In its letter to Bureau Veritas of 7 May 1996, the Maritime Directorate then modified the marking diagram for national freeboard corresponding to the freeboard that was assigned in 1972 and a copy of the sailing certificate dated 8 May 1996 for the area "Small coastal trade and for voyages between the port of Moss, Norway and Karlshamn, Sweden". The sailing certificate was valid until 12 September 1999, and the Directorate pointed out that, until the Swedish shipping authorities accepted use of the certificate, the vessel should be loaded in line with the international load line certificate.

The shipping company's lawyer then replied to the Maritime Directorate, stating that limiting the sailing area to the Karlshamn – Moss route was not acceptable, and that the restriction had to be based on a misinterpretation of the Ministry's ruling. The Directorate was asked to inform Bureau Veritas that loading down to national freeboard was not restricted to the Karlshamn – Moss route, but would depend on what dispensations the ship had at any time.

The shipping company's lawyer then stated to the Ministry that the Ministry's ruling meant that the vessel could keep domestic load marks after it switched to NIS and that the vessel could use the Swedish and Norwegian permits from 1977. The lawyers believed the Maritime Directorate's requirement that the Swedish shipping authorities should accept using the certificate was not in accordance with the Ministry's ruling, in that it meant the shipping company would have to apply to the Swedish shipping authorities for a permit the shipping company had already been granted. The Ministry was asked to instruct the Maritime Directorate to withdraw the instruction to Bureau Veritas so the shipping company could use national freeboard in accordance with the permit issued by Swedish authorities in 1977.

The Maritime Directorate pointed out to the Ministry of Foreign Affairs that sailing between Norwegian and Swedish ports was to be regarded under Article 2 of the Load Line Convention as an international voyage and that this required an international load line certificate. The Directorate also stated that vessels sailing in Small Coastal Trade or less had been granted a reduction in freeboard, i.e. national freeboard. The Directorate also referred to its permit from 1977, and pointed out that

the permit to load down in excess of the requirements of the international load line convention in Swedish waters could only be granted by the Swedish shipping authorities. The Directorate then pointed out that, since the vessel had switched registers since the permit was issued, it believed that both the Swedish authorities and the vessel's classification society had to give their consent before national freeboard could be used again in Swedish waters.

The shipping company's lawyer pointed out to the Ministry that the Swedish Maritime Directorate's permit from 1977 did not say anything as to registering with a particular register: so they found it hard to understand how, as a result of switching register, the Maritime Directorate could demand that a new application had to be sent to the Swedish shipping authorities when the existing permit did not contain any such requirement. The Ministry was asked to instruct the Maritime Directorate to issue the necessary certificate.

In its letter to the Maritime Directorate dated 20 September 1996, the Ministry pointed out that its ruling meant that the appeal had been upheld in connection with the application to maintain the coastal cargo mark for the MS Langeland. In other words, the ship could retain the permit it already held to use national load marks when sailing between Moss and Karlshamn. The fact that, in purely factual terms, the maintenance had resulted in the issuing of a new certificate should not be of any significance in relation to the permit the ship had from the Swedish authorities to use national load markings on that route. The Ministry also pointed out that it was still a condition for using the permit / certificate that there was a current permit from the Swedish authorities. Whether the permit the Swedish authorities issued satisfied that condition was a matter between the shipping company and the Swedish authorities, according to the Ministry of Foreign Affairs. The Maritime Directorate was asked to issue the necessary documents, but it was pointed out that it should be stated that using the certificate or permit was conditional on there being a current permit from the Swedish authorities for such loading in Swedish waters.

In its letter of 27 September 1996, referring to the Ministry's letter of 20 September 1996 and the Directorate's own letter of 7 May 1996, the Maritime Directorate instructed Bureau Veritas as follows: "the Langeland – LDJB3 may be loaded in accordance with the Trading Certificate issued by the Norwegian Maritime Directorate 8 May 1996, provided that acceptance from the Swedish maritime authorities for the use of this certificate in Swedish coastal waters exists. Please inform the owner as soon as possible."

History of stability issues

The Langeland first had its stability approved by the Maritime Directorate on 7 December 1971. These calculations were based on inclining tests conducted on 13 October 1971, with results as follows:

Lightship displacement	799.30 t
Vertical centre of gravity over keel (VCG)	4.79 m
Longitudinal centre of gravity forward of aft perpendicular (LCG)	29.40 m

The inclining test report noted that there was approx. 2 cm of wet snow on deck during the test which may have affected the results. When calculating lightship values, snow deducted from 'ship heeling' is 11.0 t and VCG equal to 8.00 m. The stability calculations were carried out for a maximum draught of 3.85 m with 1250 t cargo-specific gravity 0.49 t/m³ stowed homogeneously up to the shelter deck (not in hatch coamings). The conditions were calculated with 0.50 m aft trim fully bunkered and 0.19 m forward trim in arrival condition with 10% bunkers. Calculations were also made for carrying containers distributed with 820 t in the cargo hold and 220 on top of the hatches. The draught under this container load was calculated as 3.49 m, and no water ballast was included. The container conditions were calculated with 0.36 m forward trim on departure (fully bunkered) and 0.86 m forward trim on arrival.

On 28 November 1972, the Maritime Directorate approved a loading condition to carry 300 t of deck cargo from Stavanger to Kiel. This condition was based on departing conditions in ballast that were approved on 7 December 1971. In this condition, the deck cargo was located with its centre of gravity 10.0 m over the keel, equivalent to approx. 3.55 m over deck, the cargo hold empty and all ballast tanks full. These were the forepeak tank, bottom tanks 1-3 starboard and port and bottom tank no. 4. Total water ballast was 486 t and the condition had a resulting draught of 3.46 m.

On 30 January 1973, the Maritime Directorate approved departure and arrival conditions with 600 t deck cargo and cargo hold empty. The deck cargo had its centre of gravity 10.23 m over keel, equal to approx. 3.77 m over deck, and the water ballast was the same as in the condition with 300 t deck cargo described above, 486 t. The draught in departure condition was calculated as 3.89 m and the arrival condition met the stability requirements marginally. Departure and arrival conditions were also approved with 2130 t of homogenous load in the hold and hatch coamings. That was equivalent to a cargo-specific weight of 0.77 t/m³ and the departure condition was calculated with a depth of 5.300 m. None of these conditions were calculated with the longitudinal centres of gravity in mind, and so did not indicate trim.

On 23 May 1973, the Maritime Directorate approved the homogeneously loaded departure conditions shown below (cargo distributed evenly in hold and hatch coamings):

Draught mould. [m]	Cargo in hold [t]	Spec. grav. of cargo [t/m ³]	Cargo on deck [t] / COG over deck [m]	Maximum righting lever GZ at approx.. angle [°]	Max. righting lever GZ [m]	Displacement [t]/VCG [m]
5.400	2209.22	0.80		35 - 40	0.499	3350 / 4.232
5.625	2542.97	0.92		35	0.476	3495 / 4.317
5.625	2442.97	0.88	100 / 3.55	30	0.395	3495 / 4.480
5.625	2342.97	0.85	200 / 3.55	30	0.313	3495 / 4.644

Corresponding arrival conditions were also approved. None of these conditions included any water balance, nor did the arrival conditions. The calculations did not state trim, so they did not reflect longitudinal centres of gravity.

On 6 February 1974, the Maritime Directorate approved the Langeland's stability for carrying grain in bulk. This approval was given on the condition that the surface of the grain should be levelled out so it lay up in the hatch coaming at least 600 mm above the level of the uppermost deck, the shelter deck. This approval was based on grain stability calculations in departure and arrival conditions for the stowage factors of 45, 50, 55 and 65 ft³/t, which is equivalent to specific weights of 0.79 to 0.54 t/m³. It also approved minimum GM (metacentric height) curves for variable stowage factors in relation to displacement which were designed to help the master control stability when carrying grain in bulk.

On 9 August 1976, the Maritime Directorate agreed to carrying cranes in the upright position from Oslo to Turku, Finland. That meant the hatch covers could not be closed, so the Directorate required at least two tarpaulins to be laid over a solid frame built of squares round the cranes so water could not get into the cargo hold. The Directorate demanded that they inspect the arrangement before the ship sailed, and that they had to find the stability satisfactory. The permit was conditional on the classification society and insurers consenting to the arrangement and the voyage being made in moderate weather.

On 13 January 1977, the Maritime Directorate informed the I/S Janneland shipping company, referring to the stability calculations that were approved on 23 May 1977, that if they wished to carry deck cargo in excess of 200 t, they had to submit separate, detailed calculations for this for approval. The reason for this requirement was that the Directorate had received load conditions the vessel's captain had produced using a Consultas Ship Calculator STB no. 566, which was being used as a load calculator on board. These conditions, which were difficult to check because they only gave weights and a resulting GM, were calculated with 600 t of deck cargo with a centre of gravity 10.1 m over keel, an empty cargo hold and ballast water in bottom tanks 1, 2, and 3 port and starboard. They also included a Brøyt digger as an additional deck cargo of 57 t. The Directorate stated that the calculation results were otherwise acceptable.

On 3 June 1977, a maritime court of inquiry was held into an accident involving load shifting and being lost in the Skagerrak on 28 March 1977. What was then the Janneland had loaded a cargo of hatch covers for container ships at the Ankerløkken yard in Florø. These covers were to be carried to Naksoy in Denmark. Some covers and accessories were stowed in the cargo hold, 250 t in all. The deck cargo consisted of 15 hatch covers 11 x 13 m that were stowed on top of one another in two stacks, with their longest side across the ship. Loading conditions produced for the journey showed the deck cargo as 330 t with a centre of gravity 10.0 m over keel. Ballast water was stated as 625 t in total, giving a displacement of 2143 t, VCG of 4.55 m, draught of 3.80 m, GM 1.25 m and max. GZ approx. 0.85 m occurring at approx. 40° list.

The Janneland rounded Lista and set course for Skagen off Ryvingen. The weather grew worse, and they gradually had a fresh gale with rough wind seas from the

north-east as well as an old swell from the south-west. They opted to try to head in towards Kristiansand to reach shelter and wait for better weather. The vessel was held up against the wind at a speed of around 3 knots and she was rolling rapidly while the sea washed in over the deck and deck cargo. Having rolled two or three times violently heeling 10-20° to either side, the lashings broke and the whole deck cargo went overboard.

On 6 June 1977, the Maritime Directorate accepted that a Brøyt X-4 digger mounted on a traverse which could be moved along the ship be regarded as deck cargo. The weight of the digger and traverse was stated as 57 t, with the centre of gravity 8.50 m over keel and 2.05 m over deck. The Directorate stated that, in the light of a renewed assessment, they could accept up to 657 t deck cargo with a centre of gravity not more than 9.96 m over keel (3.50 m over deck). This meant that the digger was included in the maximum deck cargo allowed. It was also pointed out that it was a condition of being allowed to carry deck cargo that the vessel was not loaded less favourably than in the conditions on which its comments of 13 January 1977 were based. It was also assumed that the ship's master would check that the stability met current requirements, using stability tools if necessary.

On 18 August 1989, the Maritime Directorate sent copies of the letter of approval and stability calculations to its station in Bergen. It was pointed out that the calculations approved on 23 May 1973 did not include the Brøyt machine, which meant the deck cargo under those conditions had to be reduced by 57 t. It was also pointed out that the calculations approved on 6 June 1977 assumed the master would check stability using the STB 566 load instrument the ship was equipped with. If this instrument was no longer in use, new load conditions had to be submitted for approval; the lightship data had to be corrected to allow for the Brøyt machine in that case.

The Accident Investigation Board has not found any stability documentation produced after the date of this letter.

History of the hull (construction, strength and inspections):

The Accident Investigation Board has not had access to the original dimension calculations or class drawings from the Langeland's first classification society Det norske Veritas. DNV supervised its construction, and the vessel was classified from when it was delivered as a new build until the classification was deleted in 1986 at the owners' request. The vessel was classified with Bureau Veritas from the same year. The DNV could not present any original documentation as this had been routinely shredded after 20 years.

Less than a year after the vessel was delivered in 1971, DNV issued a load line certificate for the Langeland as a closed shelter decker. While investigating the loss, the Accident Investigation Board has not found any documentation to indicate that the Langeland had to be strengthened to increase the draught with the 'enclosure': so the vessel was very likely designed and built to be loaded down with the upper deck as freeboard deck.

As the vessel was classified outside the Maritime Directorate throughout its life, the Directorate does not have any documentation of note concerning the hull. In the National Archives, however, the Accident Investigation Board found strength calculations from 1976 which the Directorate supplied. These calculations included dimension checks on the holding brackets for use when parking the digger. Dimensioning forces on the brackets were calculated during rolling, yawing and pitching. Loads on the deck rails were also calculated when using the digger. These calculations concluded that the existing deck and deck beams were strong enough for the arrangement with the digger, so no further reinforcements were required.

The class status report and history which the Accident Investigation Board received from Bureau Veritas include limited information from the first classification periods up until 2004. The vessel was inspected in dry dock on 17 September 2004 in the course of renewing its classification for up to 12 September 2009. BV re-inspected the hull in April 2005, after the Langeland was held back. The vessel then had its annual hull inspection in August 2005 with the vessel afloat.

Its next hull inspection was carried out by divers working for BV in May 2006 after the vessel ran aground. Impressions were found in the skin plates in bottom tank 2 starboard and impressions, cracks and weld seams destroyed in frames 73 – 75, and temporary repairs were ordered before sailing, with permanent repairs to be carried out the next time the ship was in dock, by 15 October 2006 at the latest.

BV's inspection in the autumn of 2006 included a periodic bottom inspection, focusing on the damage after it ran aground in May that year. The inspection report stated the following about the hull:

- Deformed starboard bilge keel was replaced over a length of 8 m.
- Deformed skin plates in the bilge area on the starboard side were replaced from frames 45 to 77, the destroyed strength members were also replaced.
- The tanks involved were pressure-tested following the repairs with satisfactory results.
- All three propeller blades were damaged. The vessel had three reserve blades which were installed.

Divers inspected the bottom in February 2007 following a grounding. A minor impression and cracks were observed at the transition between the stern and the side of the hull on the port side. The damage was noted as having been satisfactorily repaired for the time being, with instructions that permanent repairs had to be made by 12 December 2007.

Annual and interim hull inspections were carried out in dock in the period 12.- 29 November 2007. The thickness of the steel was also measured at this time. The inspection report findings on the hull were mainly as follows:

- Impression in skin plate in the bow. 0.6 m² of 14 mm plate was replaced.
- The deck beams at frames 18 and 20 under the poop deck on the starboard side were found to be corroded and cracked. These beams were replaced.

- Frames 18 and 19 with knee plates on the starboard main deck were found to be cracked and corroded at their lower end, replaced over a length of 1 m from deck.
- The deck plates in the main deck between frames 25 and 26 were found to be worn and corroded. Based on the measured thicknesses, 9.4 x 0.65 m was removed and replaced with new 8 mm plate.
- Following the thickness readings, an area of 1.2 x 2.5 m between frames 22 and 25 in the shelter deck on the port side was replaced with new 8 mm plate.
- The rear section of hatch cover no. 17 was replaced over its full width and 300 mm length.
- Deformation / damage was observed to frames in the cargo hold. Damaged sections of frame 54 starboard and port and frame 30 port were replaced.
- New Neptune 03 sensor for high water levels in the cargo hold was fitted and trialled with satisfactory results for audible and visual alarms.
- The forepeak bulkhead frame 98 at the chain locker was found to be corroded and failed the minimum remaining thickness test. An area of plate 2.9 m wide and 2.7 m high was replaced with 7.5 mm plate.
- Below the water line, impressions and cracks were found in the impact plate at frames 66 – 67 in bottom tank no. 2 port, 0.33 m² was replaced with new plate. Dents and cracks were also observed in the bilge plate and in strength members at frames 57 – 61 in bottom tank no. 2 starboard, an area of plate of 2.73 m² was replaced and 0.2 m² of the strength members replaced with new ones. The tanks were topped up with water (overflow) and found to be watertight.
- The ends of the propeller blades were bent, and cracks were observed. The blades were repaired while in the yard with satisfactory results.
- Damage following a grounding at the transition between the stern and hull side was repaired permanently.
- A number of stiffeners on the longitudinal bulkheads in the aft peak tank were observed as cracked. A total of 3.3 m of the stiffeners were removed and replaced with new steel.
- After measuring the thicknesses of all overboard pipes between skin plate and valves in the engine room, 10 pipe connections were replaced in all.

Steel is allowed to lose up to 20% of its original thickness. Thickness measurements showed the thickness of the shell plating had mostly reduced by less than 10%. The exception was the keel plates on either side of the area by the bow thruster, where substantial corrosion was noted, with a maximum reduction of 17.4%. Upper longitudinal stiffener on the starboard hatch coaming were also found to have been reduced by 15.4%, and a number of plates in the tank top in the vicinity of frames 30 and 68 by up to 20%.

The vessel's last annual inspection, from 9 to 16 December 2008 with the vessel afloat, resulted in the inspection report commenting on the hull as follows:

1. Deck plate on the main deck at frames 93-94 was found to be corroded. Part of deck plate removed and replaced. Frame 93 under deck plate found

- to be corroded. Upper section of frame removed and replaced with 8 mm plate. Repairs satisfactory.
2. Water level alarm sensors in cargo hold tested for audible and visual alarms with satisfactory results.
 3. Collision bulkhead and other watertight bulkheads inspected insofar as visually possible. No damage observed.
 4. Inspection of fore and aft peak tanks. Plates and strength members slightly corroded. No cracks or deformations. Part of the spindle for remote operation of the bottom valve in forepeak tank replaced with new material as a result of the corrosion. Tanks found to be in generally satisfactory condition.
 5. "Close-up survey of sufficient extent, minimum 25% of frames, to establish the condition of the lower region of shell frames including approximately the lower one third length of side frames at side shell and side frame end attachment and the adjacent shell plating in a forward lower cargo hold": On the starboard side, frames 81, 87 and 89 were found to be corroded at their top sections where they connected to deck. Parts of the frames removed and replaced with new steel. On the port side, longitudinal stiffener between frames 79 and 80 was found to be corroded and this section was replaced with new steel. Repairs made were satisfactory.
 6. Inspection same as in 5 to be carried out for another selected lower cargo hold. See statements in 5.
 7. "If repairs are needed in one cargo hold, close-up survey of all the shell frames and adjacent shell plating of that cargo hold and associated tween deck spaces (as applicable), as well as close-up survey of sufficient extent of all remaining cargo holds and tween deck spaces (as applicable)". See statements made in 5.

From these inspection reports and the thickness testing report from 2007, relatively few frames were checked in the cargo hold, and the steel dunnage ('inner skin') under the former main deck is not mentioned in the reports. Sections 5, 6 and 7 above cite descriptions from the inspection reports of what is to be checked. The focus must be put on checking the lower areas of the frames, but results from such control are missing in the reports. The Accident Investigation Board believes this is explained by the fact that there is no way of checking the lower areas of the frames in the cargo hold because of the steel dunnage between the tank top and former main deck.

Effects of modifications to the Langeland which are not directly relevant to the loss.

The side and bottom dunnage of wood, tweendeck hatches and some of the tweendeck in the sides in the cargo hold between frames 25 and 90 was removed before 1982. With the tweendeck removed, the Langeland had to be regarded as a single decker with the shelter deck as the only complete deck: so the term 'open shelter decker' no longer applied. From 1972 onwards therefore, the vessel was only certified as 'closed' with a gross tonnage of 1208. The tonnage triangles on the ship's sides, indicating that the vessel was an open shelter decker, were probably painted over.

In 1982, however, the vessel was given a new combined tonnage certificate as an open / closed shelter decker with gross tonnages of 499 and 1181 respectively. This meant that the conditions for being issued with such a tonnage certificate with 'open' gross tonnage of 499 no longer applied. The 'closed' gross tonnage of 1181 was also calculated based on wooden bottom and side dunnage being installed in the cargo holds. This was removed before 1982, as stated, probably in 1972, so the 'closed' gross tonnage should have been 1208 from 1972.

The 1982 tonnage certificate was renewed when the Langeland changed back to Norwegian flag after having been registered in Denmark in 1990 and the incorrect 'closed' gross tonnage of 1181 was ultimately stated as safety tonnage in the vessel's 1969 tonnage certificate issued in 1994.

The Accident Investigation Board has not looked into what the consequences of the Langeland not having the correct tonnages might be; but it is assumed that this did not have any adverse effects in terms of safety.

Permission from Swedish Maritime Administration to use domestic freeboard in Swedish waters:

The Accident Investigation Board has received the Swedish Maritime Administration's statement as to the validity of its original permission to use domestic freeboard in Swedish waters from 1977. The Swedish Maritime Administration's opinion was based on the same history of modifications, changes of ownership, changes of flag, etc. as are reproduced in the section on factual information.

The Swedish Maritime Administration was clear that the permit did not apply to sailing between Swedish and Norwegian ports or vice versa. As to the validity of the permit generally, especially since the Langeland changed flags in 1990, the Swedish Maritime Administration was unwilling to give its final opinion until the matter possibly had been assessed legally.

The Accident Investigation Board has not investigated the above any further, as loading down to national freeboard was not the case when the Langeland was lost.

VEDLEGG C

DETALJER OM SJØ- OG BØLGEFORHOLD OG PÅVIRKNING PÅ FARTØYET

Oppsummering

– 0354: Fartøyet hadde både hiv- og rullebevegelser som følge av sjøen. Da sjøen kom inn aktenfor tvers førte dette til at skipet også giret noe. Med det lave fribordet, sett i forhold til bølgehøydene, ble det mest sannsynlig jevnlig sjø på dekk. Bølgekraftene virket på hele skipets babord skuteside.

- a. Da fartøyet gikk nordvestover på sin planlagte rute (før kl. 0354) kom bølgene og vinden inn mot babord skuteside. Den første markante svingen mot styrbord kl 0354 kan derfor ikke forklares med 'broaching'.

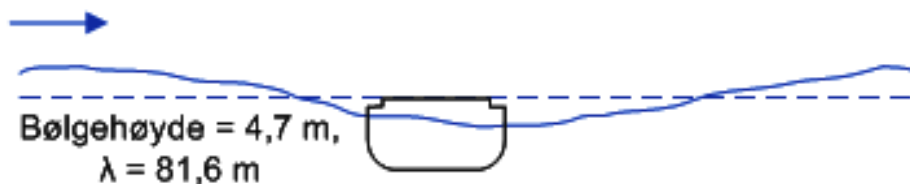

0354 – 0456 (62 minutter): Fra kl 0354 ble fartøyet utsatt for store bølgelaster som følge av at skipet fikk bølgene inn fra akter/babord låring. Skipet har fått store hogging- og saggingmomenter samt skjærkrefter i tillegg til torsjonsmoment.

- b. 0354 – 0421 (27 minutter):
Etter at fartøyet endret kurs og fikk bølgene aktenfra og etterhvert på babord låring ble fartøyet utsatt for større bølgelaster med tanke på skipet som skrogbjelke.
- c. 0421 – 0456 (35 minutter):
Bølgene var i utgangspunktet omkring 80 meter lange (10 meter lengre enn skipet). Da fartøyet gikk over grunnere vann (endelig vann for bølgene) ble bølgene stuvet sammen slik at de ble kortere, høyere og dermed krappere. Det er antageligvis i dette tidsrommet fartøyet er blitt utsatt for de største hogging- og sagging-momentene da bølgelengden har vært omtrent like lang som skipslengden.

Bølgefeltretning fra: 230°
Heading: 50°
 $\lambda = 81,6$ m
 $H = 5$ m
 $C_z = 11,3$ m/s
 $H/\lambda = 0,06$



Bølgefeltretning fra: 230°
Heading: 50°
 $\lambda = 70$ m
 $H = 6$ m
 $C_z = 11,3$ m/s
 $H/\lambda = 0,09$



Bølgefeltretning fra: 230°
Heading: 50°
 $\lambda = 81,6$ m
 $H = 8$ m
 $C_z = 11,3$ m/s
 $H/\lambda = 0,10$



Bølgefeltretning fra: 230°
Heading: 50°
 $\lambda = 70$ m
 $H = 9$ m
 $C_z = 11,3$ m/s
 $H/\lambda = 0,13$



0456 – 0511 (15 minutter): De siste 15 minuttene var sjøen trolig uryddig der den bestod av bølger i forskjellige retninger og med forskjellig bølgelengde og -høyde. I dette tidsrommet var sjøforholdene de samme hele tiden (ingen endringer mot slutten).

- d. Dybden i det område fartøyet gikk ned er for stor til at bølgene (som er målt ved Väderöarna) er blitt endret betydelige på grunn av bunnforholdene akkurat der.
- e. Fartøyet er funnet ca. 160 m i nordlig retning i forhold til posisjon for det siste AIS-signalet.

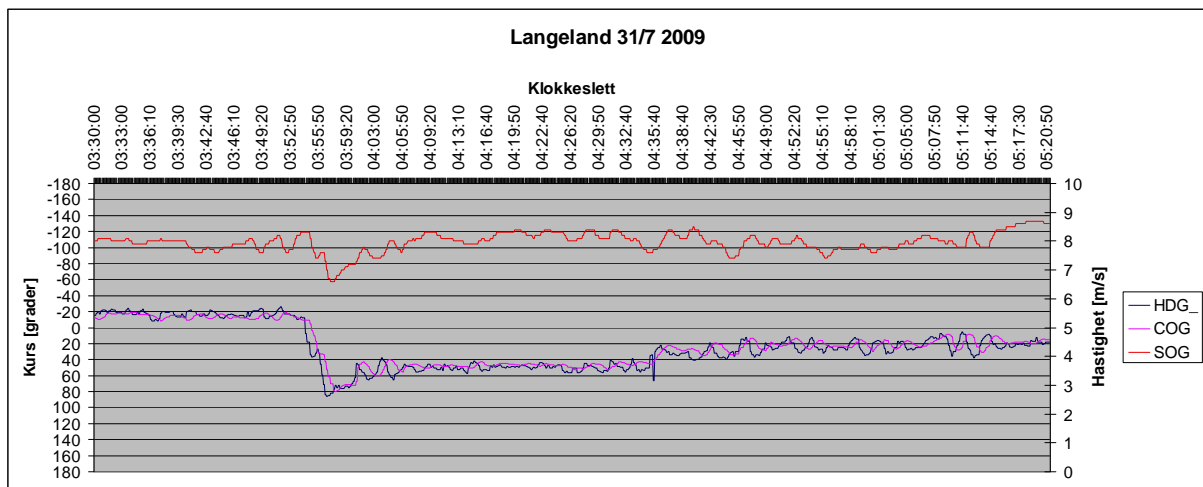
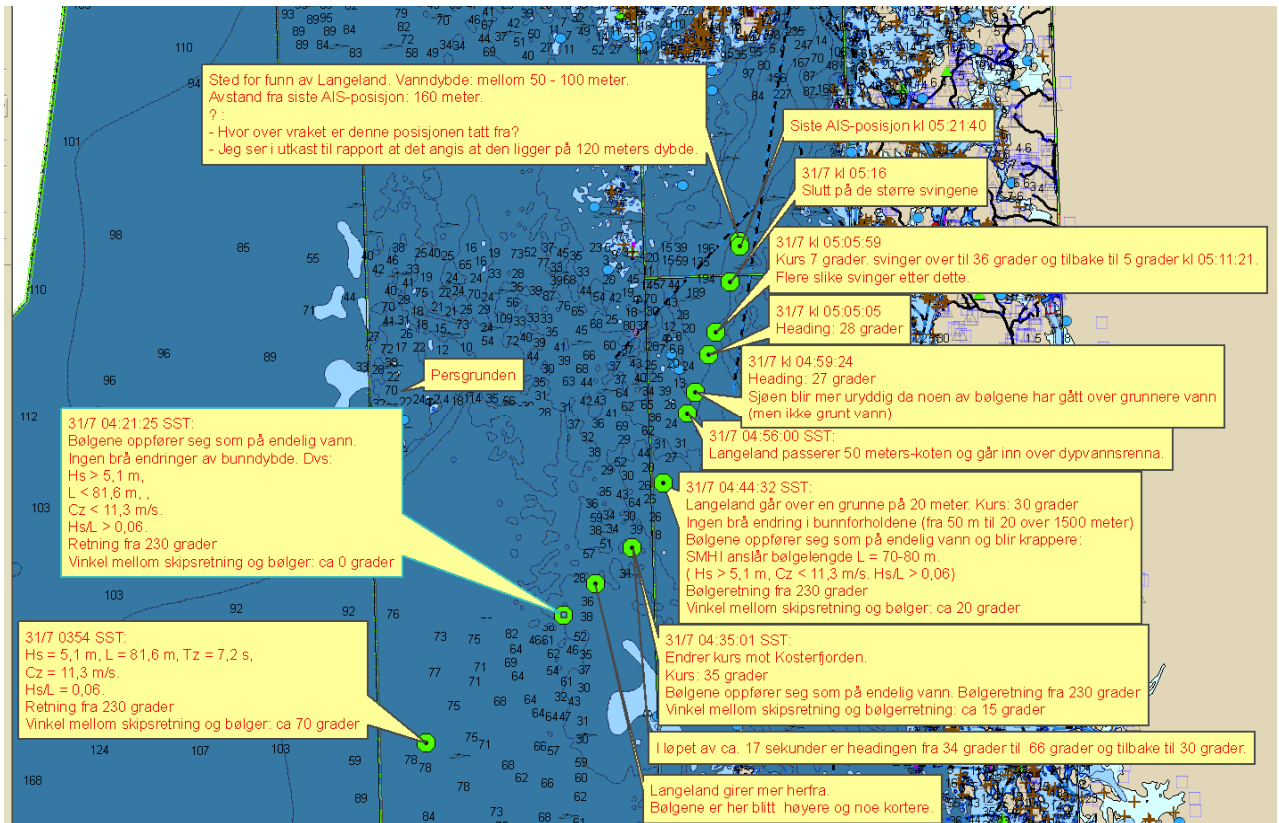

Fartøyetts bevegelser, bølge- og bunnforhold.

Før Väderöarna (- 0230)

- a. 31/7 kl 02:30
- b. Posisjon: N 58,4341011 E 10,94966698
- c. Heading: 340 grader, COG: 340 grader SOG 8,1 kn
- d. Vinkel mellom bølgeretning og skipets langskipsakse: 70 grader.
Dvs mot babord side.
- e. Bølgeforhold:
 - i. Signifikant bølgehøyde, $H_s = 4,7$ m
 - ii. Maksimal bølgehøyde, $H_{max} = 7,2$ m
 - iii. Bølgeperiode, $T_z = 7,2$ s, $T_p = 10,2$ s
 - iv. Bølgeretning $\theta_{Tp} = 230,6$ grader
 - v. Bølgelengde $L = 81,6$ m
 - vi. Bølgehastighet $C_z = 11,3$ m/s
 - vii. Steilhet $H_s/L = 0,06$
- f. Dypt vann.
 - i. Dybdeforholdene er 80-90 meter, men enkelte områder er ned til 50 meter. Da bølgelengden er 81,6 meter vil ikke bølgene bli påvirket av bunnforholdene.

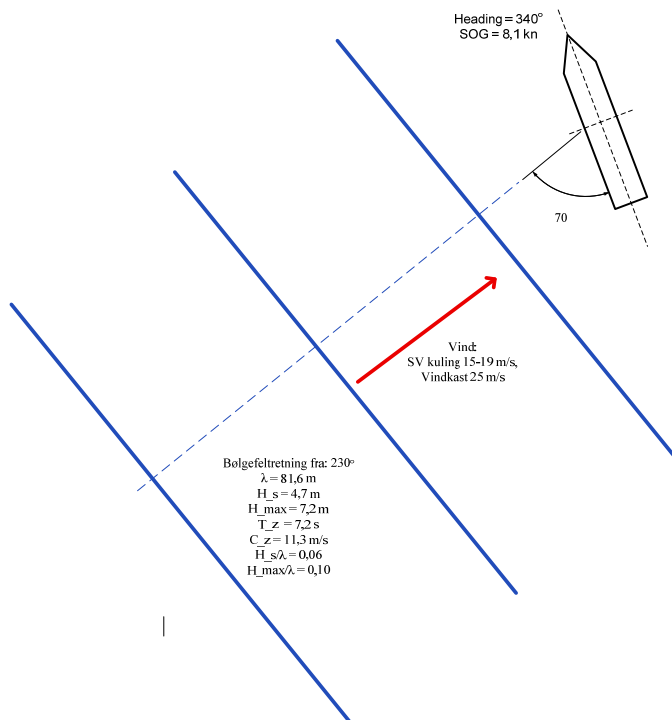

Vest for Väderöarna (0254)

- g. Langeland passerer vest for målebøyen den 31/7 kl 0254.
Langeland passerer 600 m vest for målepunktet til SMHI ved Västeröarna.
- h. Posisjon N 58,48383331 E 10,9227669
(N 58 29,03 E 10 55,37)
- i. Dybdeforholdene er rundt 70 m. Enkelte dybder Langeland går over er ned i 50 meter.
- j. Bølgene kommer fra 230 grader. Langeland har heading 340 og COG 350 grader. Det vil si bølgende treffer nesten rett i siden på Langeland (70 grader mellom bølgeretning og skipets langskipsakse).
- k. Bølgene oppfører seg for dypt vann.

Der Langeland tar første sving mot styrbord (0354 - 0400)

- l. Posisjon N 58,60606766 E 10,85876656
(N 58 36,36 E 10 51,53)
- m. Langeland begynner å svinge mot styrbord den 31/7 kl 0354. Ca. 8 nm nord-nordvest for passering av Väderöarna
- n. Topografien Langeland seiler over mellom Väderöarna og dette stedet har en jevn dybde (uten store variasjoner) på omkring 80 meter. *Bølgmålingene og beregningene fra Väderöarna er derfor representative også for dette stedet.* Bølgene oppfører seg for dypt vann.
- o. Før svingen (før 0354):
Bølgende treffer i siden på Langeland (ca 60 grader mellom bølgeretning og skipets langskipsakse).

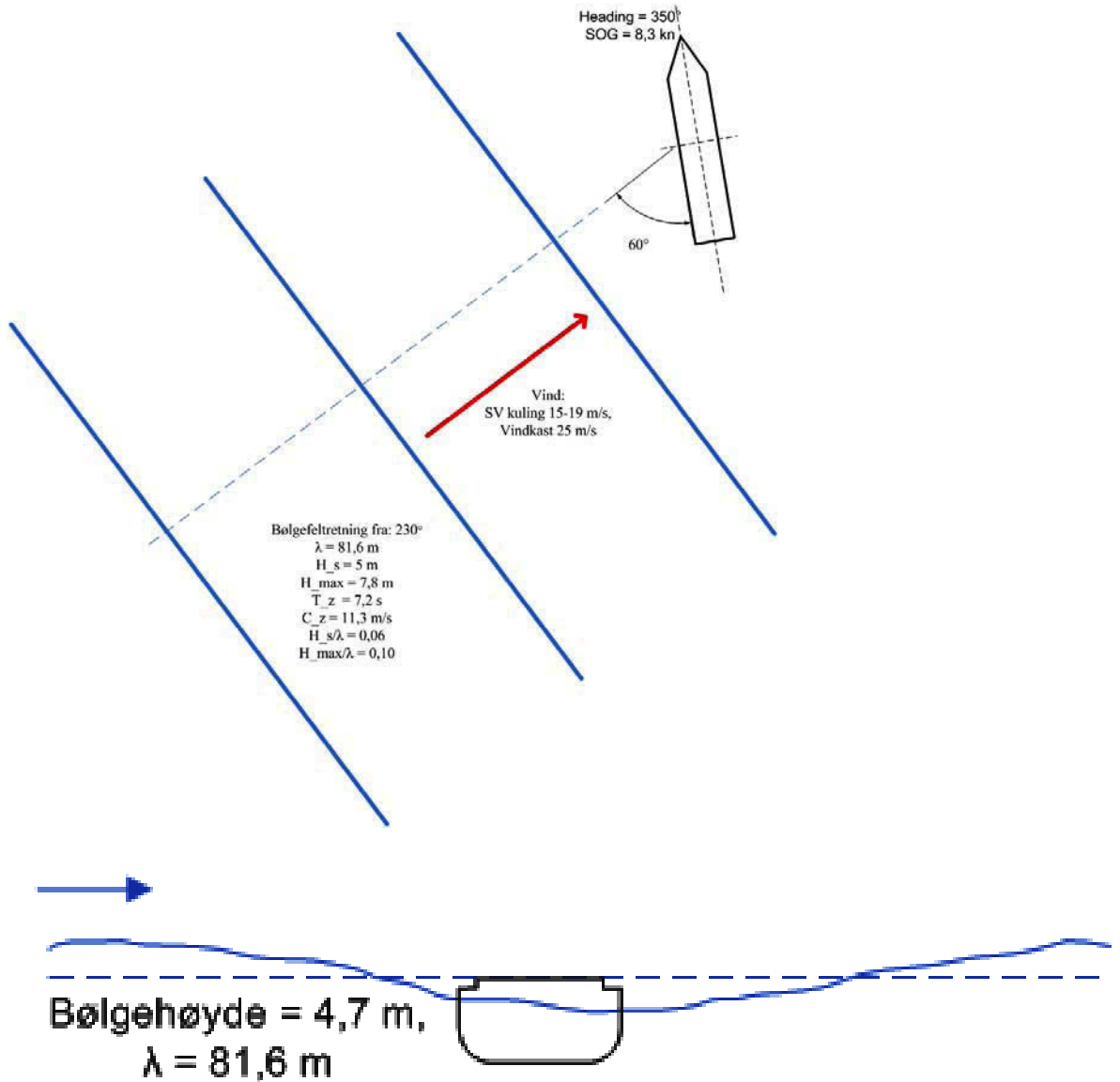

- p. Etter første sving mot styrbord (mellom 03:54 og 03:56:15):
 Fartøyet har kurs ca 35 grader.
 Vinkel mellom bølgene og langskipsaksen er 15 grader. Dvs. bølgene kommer nesten rett aktenfra, babord side.

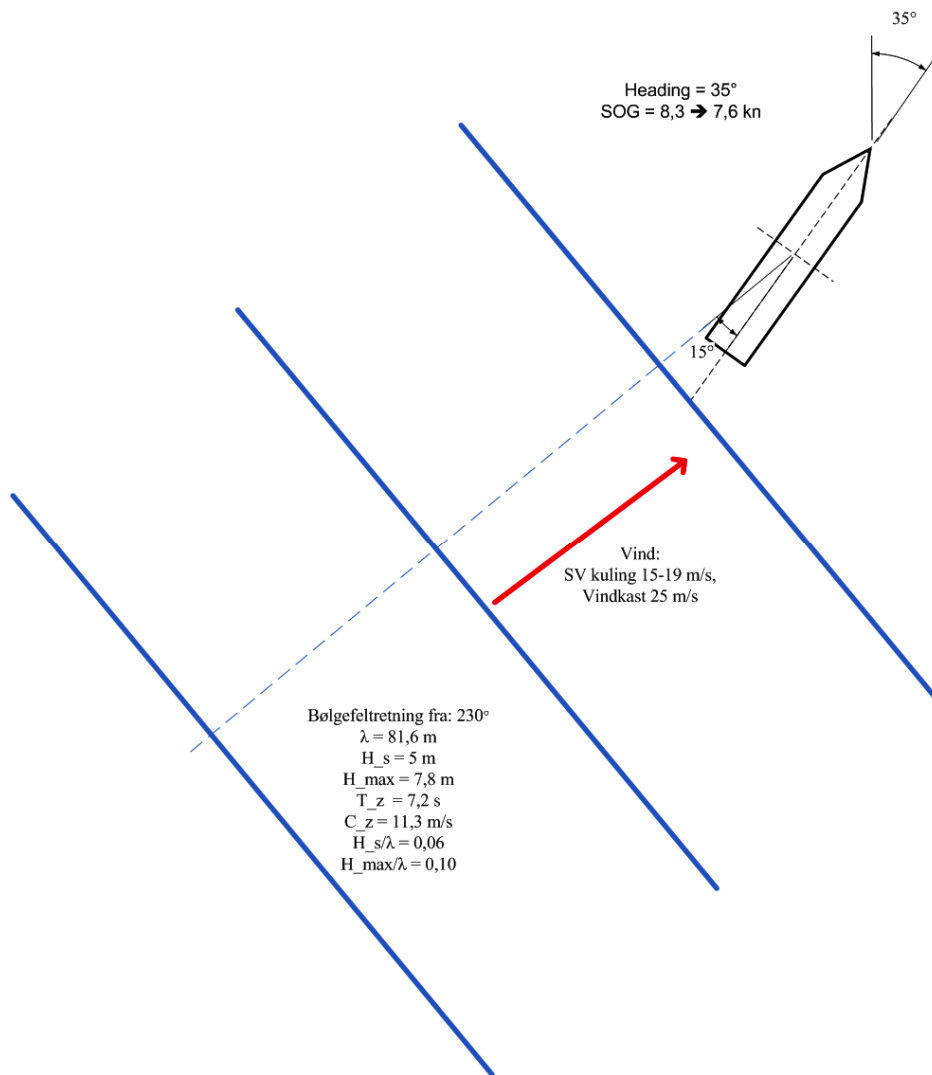

- q. Etter andre sving mot styrbord (etter 03:58:05 og frem til 04:00):
 Fartøyet har kurs ca. 72 grader. Vinkel mellom bølgene og langskipsaksen er -
 23 grader. Dvs. bølgene kommer nesten rett aktenfra, styrbord side (på
 styrbord låring).

Heading = 72°
SOG = 6,7 → 7,2 kn

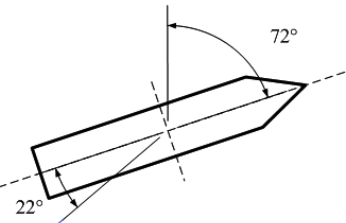

Vind:
SV kuling 15-19 m/s,
Vindkast 25 m/s

Bølgefeltretning fra: 230°
 $\lambda = 81,6$ m
 $H_s = 5$ m
 $H_{max} = 7,8$ m
 $T_z = 7,2$ s
 $C_z = 11,3$ m/s
 $H_s/\lambda = 0,06$
 $H_{max}/\lambda = 0,10$

Da Langeland går nordøstover mot land (0400 - 0421)

Etter sving svakt mot babord (etter 04:00 og frem til 04:21:25):

- r. Fartøyet har kurs ca. 50 grader. Vinkel mellom bølgene og langskipsaksen er 0 grader. Dvs. bølgene kommer rett aktenfra.
- s. Når skipets kurs er på skrå i forhold til bølgene vil det oppstå både vertikalt og horisontalt bølgemoment. Det vil også oppstå torsjonsmoment. Bølgemomentene forårsakes av de hydrodynamiske kreftene fra bølgene og treghetskrefter som følge av at skipet beveger seg i bølgene. Disse vil kunne utgjøre betydelige bidrag til de totale skjærkreftene og bøyemomentene skroget utsettes for.

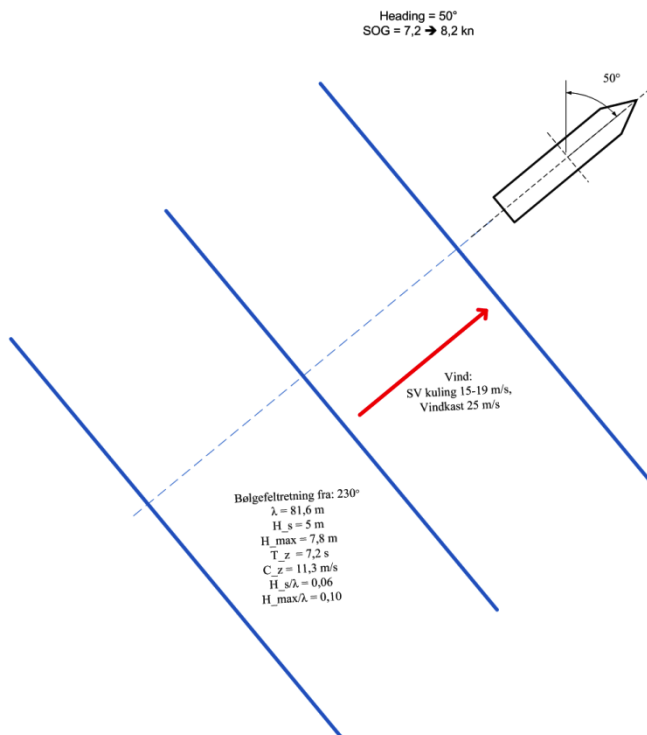

Bølgefeltretning fra: 230°

Heading: 50°

$\lambda = 81,6$ m

H = 5 m

$C_z = 11,3$ m/s

$H/\lambda = 0,06$



Bølgefeltretning fra: 230°

Heading: 50°

$\lambda = 81,6$ m

H = 8 m

$C_z = 11,3$ m/s

$H/\lambda = 0,10$



Der bølge/dypdeforholdet gjør at bølgene oppfører seg på endelig vann (0421 – 0435)

- t. 31/7 kl 04:21:25.
Posisjon N 58,64484 E 10,94439
(N 58 38,6904 E 10 56,6634)
- u. Dette er det stedet der Langeland seiler over 50 meters dybdekontur
- v. Da bølgene på dette tidspunktet er 82-90 meter lange, vil de oppføres seg som ved endeleig vann når dybden blir ca. 45 meter og mindre.
- w. Langeland går over et område der minste dybde er 28 meter, som fortsatt er innenfor endelig vann (ikke grunt vann). Endring av dybde fra 50 meter til 28 meter over en avstand på 1400 meter. Dvs. ingen brå endringer i bunnforholdene.
- x. I dette område stuves bølgene sammen slik at
 - i. Bølgelengden blir kortere
 - ii. Bølgehøyden blir større
 - iii. Bølgehastigheten avtar
 - iv. Bølgeperioden forblir den samme.
 - v. Bølgeretningen vil trolig forbli den samme som før. Dvs. bølgene kommer rett aktenfra.

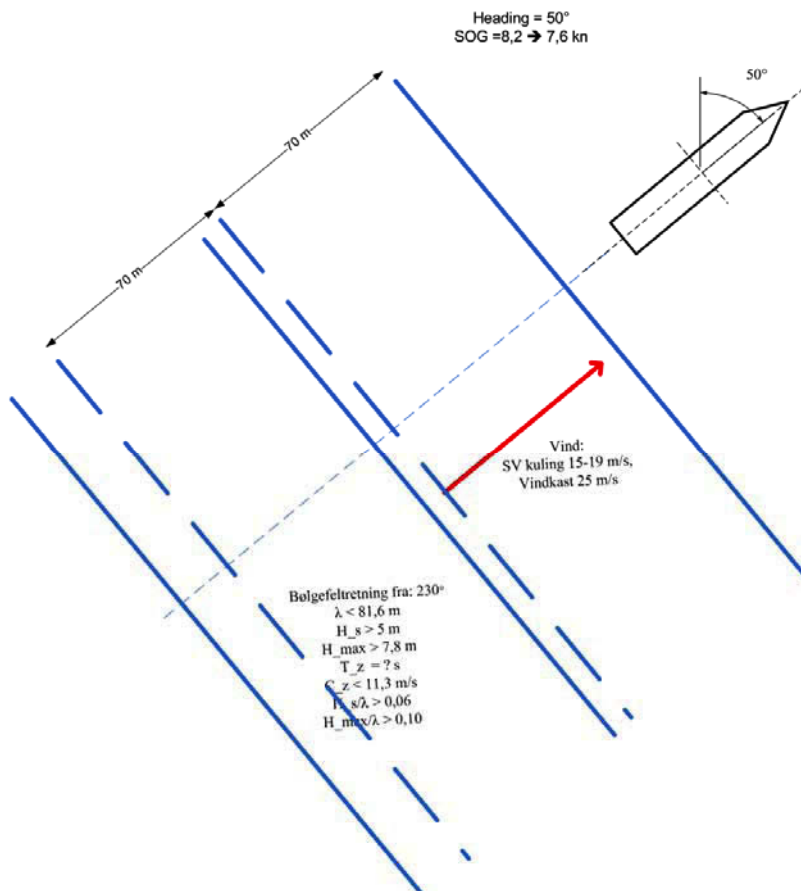

Bølgefeltretning fra: 230°
Heading: 50°
 $\lambda = 81,6 \text{ m}$
 $H = 5 \text{ m}$
 $C_z = 11,3 \text{ m/s}$
 $H/\lambda = 0,06$



Bølgefeltretning fra: 230°
Heading: 50°
 $\lambda = 70 \text{ m}$
 $H = 6 \text{ m}$
 $C_z = 11,3 \text{ m/s}$
 $H/\lambda = 0,09$



Bølgefeltretning fra: 230°
Heading: 50°
 $\lambda = 81,6 \text{ m}$
 $H = 8 \text{ m}$
 $C_z = 11,3 \text{ m/s}$
 $H/\lambda = 0,10$



Bølgefeltretning fra: 230°
Heading: 50°
 $\lambda = 70 \text{ m}$
 $H = 9 \text{ m}$
 $C_z = 11,3 \text{ m/s}$
 $H/\lambda = 0,13$



Der Langeland endrer kurs mot Kosterfjorden (0435-0444)

y. 31/7 kl 04:35:01.

Posisjon N 58,66535 E 10,98665
(N 58 39,921 E 10 59,199)

z. Kl: 04:35:01 – 04:35:29

Headingen endres fra 34 grader til 66 grader og tilbake til 30 grader.

æ. Bølgeførholdene

- i. Dybden blir mindre, ned mot 28 meter. Endring av dybde fra 50 meter til 28 meter over en avstand på 1400 meter. Dvs. ingen store endringer i bunnforholdene i forhold til områdene som ligger sydvest (der følgene kommer fra).
 - ii. Bølgeførholdene er som tidligere, dvs. på endelig vann. Bølgeretning trolig den samme som tidligere, dvs. fra 230 grader.
 - iii. Like etter 28-meters dybdene begynner Langeland å gire mer enn tidligere. I det samme området er bølgene blitt høyere og kortere enn tidligere.
- ø. Heading er på ca. 35 grader. Vinkel mellom bølgene og langskipsaksen er 15 grader. Dvs. bølgene kommer nesten rett aktenfra (mot babord side).

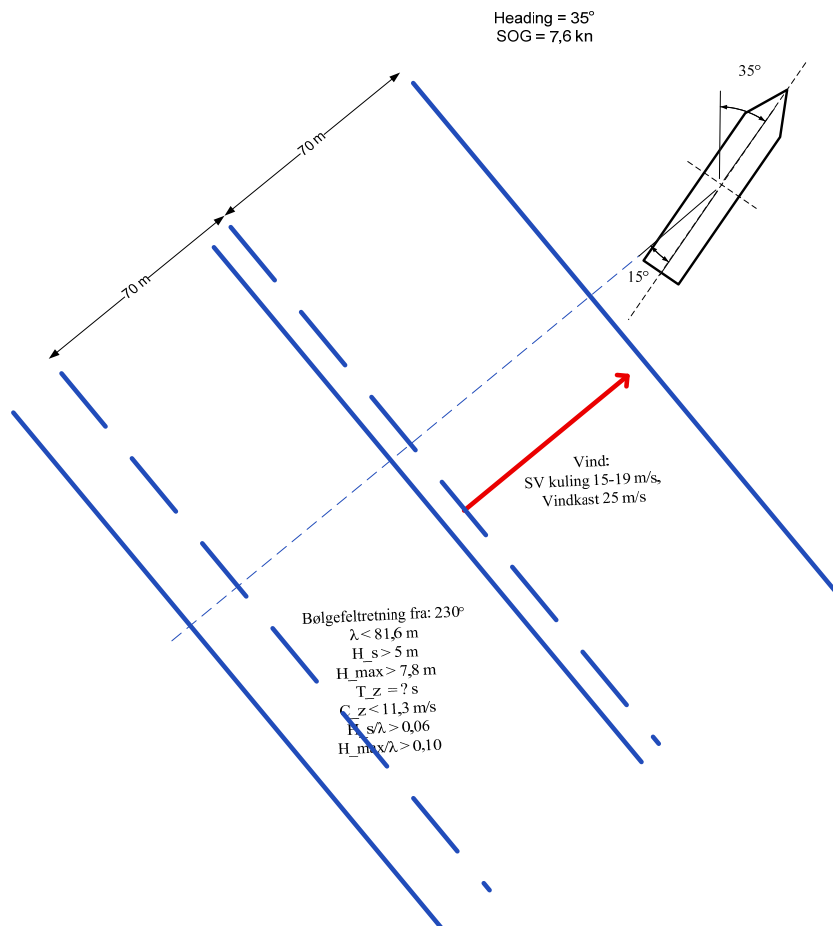

Der det blir grunnere, ned til 20 meter dybde (0444 – 0456)

å. 31/7 kl 04:44:32.

Posisjon N 58,68446732 E 11,00634956
(N 58 41,06803 E 11 0,38096)

aa. Heading er på ca. 30 grader. Vinkel mellom bølgene og langskipsaksen er 20 grader. Dvs. bølgene kommer nesten rett aktenfra (mot babord side).

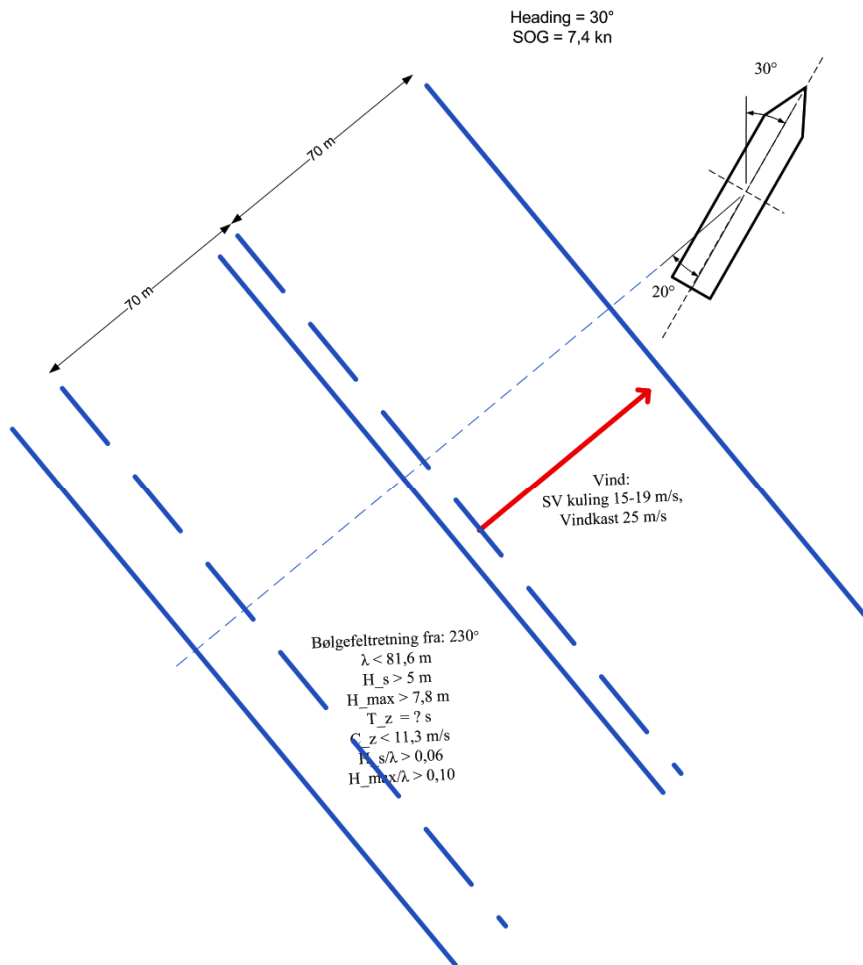

Langeland krysser 50-meters koten og kommer inn over dypvannsrenna (0456-0459)

bb. 31/7 kl 04:56:00

cc. Bølgene som kommer inn har gått over endelig vann. Endring av bunnforholdene før dette stedet har vært gradvise (ca. 25 meter over 1500 meters avstand).

Langeland kommer bak 13-meters grunna (0459-0505)

dd. 31/7 kl 04:59:24

Posisjon N 58,7132835388 E 11,02758312

ee. Bølgene som treffer Langeland har tidligere passert en grunne på 13 meter (over 200 meter), noe som nærmer seg grunt vann.

- i. Dette medfører krappere (høyere og kortere) bølger.
- ii. Det kan også bli uryddig bølgebilde (retning, høyder og lengde) på lesiden av grunnen da retningen på bølgene som går over grunnen endres. Enkeltbølger på lesiden kan derfor bli forsterket og dermed bli krappere.

ff. Det virker som Langeland har en krappere sving i denne posisjonen.

Langeland kommer bak 7-meters grunna (0505-0508)

gg. 31/7 kl 05:05:05

Posisjon N 58,7132835388 E 11,02758312

(N 58 43,4981 E 11 2,195)

hh. Som for bak 13-meters grunna

VEDLEGG D

SKJEMATISK MODELLERING AV SKROGET FOR Å BEREGNE KREFTER

Fra Marine konstruksjoner, grunnkurs (Kompendium UK-08-82), av Bernt J. Leira, Institutt for marin teknikk, NTNU

Figur 2 viser hvordan en gradvis finere modellering av de forskjellige delene av skroget benyttes for å beregne indre krefter og tilsvarende dimensjoner for hovedbæresystem og lokale detaljer.

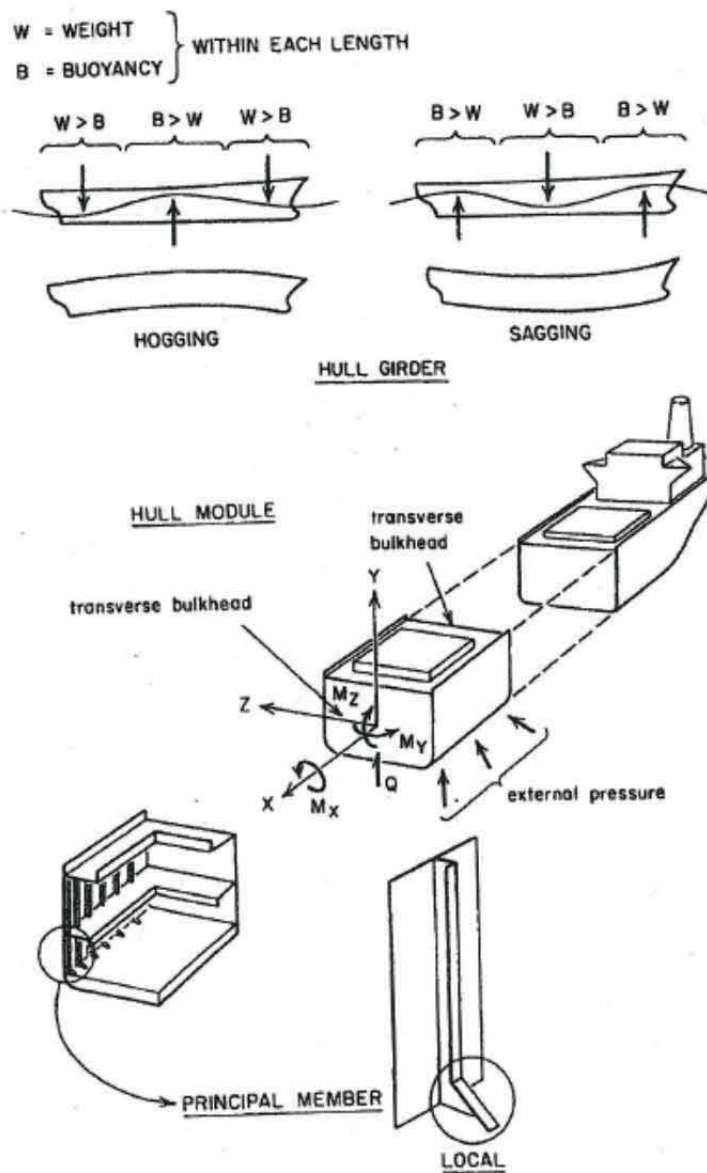

Figur 2. Sekvens av modeller som typisk benyttes ved beregning av forskjellig deler av skroget (fra Ref./11/)

VEDLEGG E

BEUFORT SKALA OG BØLGEFORHOLD

Beskrivelse av vindens påvirkning på sjøen:

Navn	Symbol	m/s	knop	Kjennetegn
Stille		0,0-0,2	0-1	Sjøen er speilblank (havblikk).
Flau vind		0,3-1,5	1-3	Vindretning sees av røykens drift.
Svak vind		1,6-3,3	4-6	Små korte, men tydelige bølger med glatte kammer som ikke brekker.
Lett bris		3,4-5,4	7-10	Småbølgene begynner å toppe seg, det dannes skum, som ser ut som glass. en og annen skumskavl kan forekomme.
Laber bris		5,5-7,9	11-16	Bølgene blir lengre, endel skumskavler.
Frisk bris		8,0-10,7	17-21	Middelstore bølger som har mer utpreget langstrakt form og med mange skumskavler. Sjøsprøyt fra toppene kan forekomme.
Liten kuling		10,8-13,8	22-27	Store bølger begynner å danne seg. Skumskavlene er større overalt. Gjerne noe sjøsprøyt.
Stiv kuling		13,9-17,1	28-33	Sjøen hopper seg opp og hvitt skum fra bølgetopper som brekker, begynner å blåse i strimer i vindretningen.
Sterk kuling		17,2-20,7	34-40	Middels høye bølger av større lengde. Bølgekamene er ved å brytes opp til sjørøkk, som driver i tydelige markerte strimer med vinden.
Liten storm		20,8-24,4	41-47	Høye bølger. Tette skumstrimer driver i vindretningen. Sjøen begynner å rulle. Sjørøkket kan minske synsvidden.
Full storm		24,5-28,4	48-55	Meget høye bølger med lange overhengende kammer. skummet, som dannes i store flak, driver med vinden i tette hvite strimer så sjøen får et hvitaktig utseende. Rullingen blir tung og støtende. Synsvidden nedsettes.
Sterk storm		28,5-32,6	56-63	Ualminnelig høye bølger (små og middelstore skip kan for en tid forsvinne i bølgedalene). Sjøen er fullstendig dekket av lange, hvite skumflak som ligger i vindens retning. Overalt blåser bølgekamene til frådelignende skum. Sjørøkket nedsetter synsvidden.
Orkan		32,6-	64-	Luften er fylt av skum og sjørøkk som nedsetter synsvidden betydelig. Sjøen er fullstendig hvit av drivende skum.

VEDLEGG F

OPERASJONELL OCEANOGRAFI



2009-09-07

Attn: Statens Haverikommission
Ylva Bexell
Box 12538 Stockholm

Tel 070 – 284 42 04

Ärende: SHK Dnr S-126/09

Händelse: Förlisning av fartyget Langeland

Allmänt:
Tider anges i svensk sommartid (SST)

1. Översiktligt väder på sträckan Karlshamn – i höjd med Lysekil (kvällen 29/7 - midnatt 30-31/7)

Resan inleddes i mycket lugnt väder. En svag högtrycksrygg täckte södra Skandinavien och lokala dimmor bildades i Bornholmsgattet. På Hanöbukten blåste en svag sydostlig vind som långsamt ökade till 5-8 m/s, signifikanta våghöjden höll sig omkring 0.5 meter.

Den 30/7 via Drogdenrännan och nordvärt till i höjd med Helsingborg (som passerades omkring kl 07) ökade sydostvinden 6-10 m/s något framför en kallfront med talrika åskväder. Fronten svepte snabbt upp åt nordost förbi Kattegatt mitt på dagen. Våghöjden i Öresund var fortfarande måttlig, endast mellan 0.5 och 1.0 meter men ökande mot middagen.

Ett lågtryck fördjupades under eftermiddagen den 30/7 strax utanför Sydnorska huvudet och rörde sig kommande 12-18 timmar norrut längs norska västkusten. I samband med detta fick m/s Langeland känna av vind mellan sydost och syd 12-kuling 16 m/s. Den sydostliga sjön utanför den svenska västkusten ökade härmed till 2-3 meter. Senare på kvällen lämnar Langeland området med sjölä från Nordjylland/Skagen och berörs därefter av snabbt stigande sjö från sydväst, varvid den signifikanta våghöjden hastigt ökar till cirka 4.0 meter, maxvågor 5-6 meter.

2. Förhållandena längs sträckan väst Lysekil – väst Väderöarna – Ramskär (31/7 midnatt - kl 05 SST)

Vädret försämrades ytterligare vidare nordvärt. SV-lig kuling 15-19 m/s dominerade och stormbyar drygt 25 m/s uppmättes vid Kosteröarna.

Vågriktningen i området konstant från SV mot NO, våghöjden 4.5-5.5 m/max 7-8 meter. I detta skede (kring kl 03:50 SST) ändrar Langeland kursen markant från NNV-lig till ONO-lig. Fartyget girar således in mot kusten och får härmed den grova sjön in rakt akterifrån. Hon ändrar sedan åter kurs till NNO-lig (15-20 grader) in mot Ramskär. Våglängden är 70-80 meter.

3. Strax ost om Ramskär (vid förlisningsplatsen, 31/7 cirka kl 05 SST)

Langeland fortsätter på den NNO-liga kursen och möter Margita kl 0520. SV-vinden har vid detta tillfälle ökat till 17-21 m/s med storm 26 m/s i vindbyarna.

Langeland kommer nu in på grundare vatten vilket medför att 5-6 metersvågorna börjar att resa sig. Innanför Persgrunden och vidare till Ramskär kan man antaga ganska kaotiska förhållanden när de branta vågorna bryter på den allmänna uppgrundningen, grynnor och skär.

Samtidigt måste man konstatera att förhållandena inte på något sätt var extrema. Betydligt grövre sjö drabbar detta område ett flertal gånger varje år i samband med stormar under höst och vinter.

Sommartid uppträder 5-6-metersvågor vid Bohuskusten endast vid något enstaka tillfälle varje år.

Dessutom kulminerade våghöjden i den aktuella vädersituationen cirka 4 timmar efter förlisningstillfället. Våghöjden vid Väderöarna steg ytterligare till drygt 6 meter, max 9.3 m omkring kl 9, sedan avtagande. Se Bilaga 2.

Ytvattentemperaturen utanför Syd- och Västkusten var vid tillfället 17 – 18 grader.

Informationskällor:

Meteorologiska observationer av vind, sikt, nederbörd, lufttemperatur etc sker varje timme från ett stort antal platser längs de svenska och danska kusterna.

Oceanografiska mätningar av våghöjd, vågriktning m fl parametrar finns endast från ett fåtal utsjöbojar.

I detta fall används främst data från SMHIs vågboj placerad utanför Väderöbod (position 58°23' N 10°56' E, bottendjup 73 meter), samt delvis data från den tyska (BSH) vågbojen placerad utanför Arkona (position 54° 53' N 13° 52' O).

Övrigt underlag:

Vågklimatet i förlisningsområdet grundar sig dels på timvärden från SMHI-bojen (se Bilaga 2), dels på beräkningar från en detaljerad oceanografisk vågmodell (SWAN) som bland annat simulerar våghöjden till sjöss.

Relevanta anpassningar i tid och rum har gjorts och formar vår slutgiltiga bedömning av väder och vågor som påverkade m/s Langeland fram till tidpunkten för förlisningen.

Resultatet av väderutredningen redovisas i detalj i tabellform som bilaga 1.

För SMHI
Torbjörn Grafström, marinmeteorolog
Lisa Lind, oceanograf

VEDLEGG G

VÆR- OG SJØFORHOLD PÅ LANGELANDS SISTE REISE

Datum	Tid (SST)	Vind (m/s)	Signifikant våghöjd (m)	Maximal våghöjd (m)	Våg-riktning	Sikt (km)	Luft-temp
Karlshamn – Helsingborg							
09-07-29	16 – 24	SO 2-7	0,2 – 0,5	0,6	SO	15-20	18
09-07-30	00 – 07	SO 5-9	0,4 – 0,7	1,3	OSO	10-20 (lokalt 1-2)	16
Helsingborg – Väst Lysekil							
09-07-30	07 – 14	SO 9-13	1,0 – 2,0	2,5	SO	10-20	17
09-07-30	14 – 20	SO-S 12-16	1,5 – 3,0	3,5 – 4,0	SO-S	5-10 (regn och åska)	16
09-07-30	20 – 22	SV 13-18	2,5 – 3,5	4,0 – 5,0	S-SV	5-15 (regn eller skurar)	15
09-07-30	22 – 24	SV 15-19 (byvind 22)	3,0 – 4,5	5,0 – 6,0	SV	5-15 (regn eller skurar)	15
Väst Lysekil – Väst Väderöarna							
09-07-31	00 – 03	SV 16-20 (byvind 25)	4,5 – 5,0	6,5 – 7,5	SV	5-15 (regn eller skurar)	15
Väst Väderöarna – förlisningsplatsen							
09-07-31	03 – 05	SV 17-21 (byvind 26)	5,0 – 5,5	7,0 – 8,0	SV	3-7 (regn eller skurar)	15

Profildata från mätning 2009-07-27, position 58° 12' N 11° 01' O

Vattentemperatur

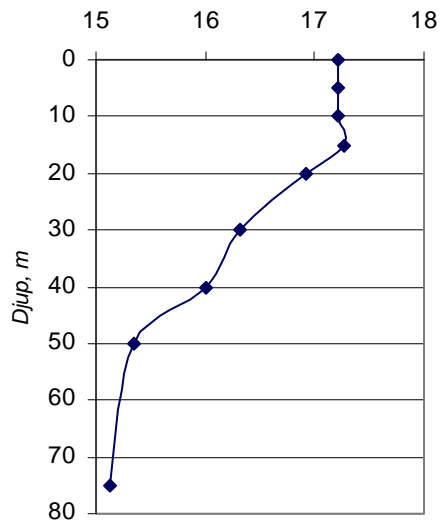

Salthalt

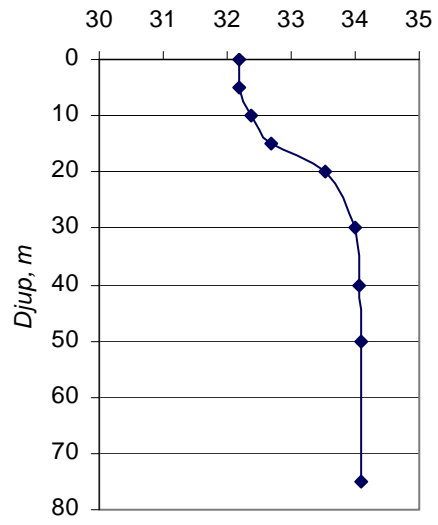

VEDLEGG H

BØLGEDATA

STATIONSNAMN: Väderöarna

POSITION, LAT: 58°29'N

POSITION, LON: 10°56'E

STATIONSBESKRIVNING: Vågboj placerad väster om Väderöarna på den svenska västkusten.

BOTTENDJUP: 73m

DATABESKRIVNING: Data har genomgått viss kvalitetskontroll.

Kod för värden som saknas eller är orimliga är -99.

Tiden är angiven i svensk sommartid (SST)

Värdena baseras på data under 30 minuter

Datum	Tid (SST)	Hs	Hmax	Tz	Tp	ThTp	L	Cz	Cp	Hs/L
2009-07-31	00:00	4,4	6,8	6,5	8,3	225,0	66,8	10,2	13,0	0,066
2009-07-31	01:00	4,4	6,8	6,5	9,4	230,6	66,8	10,2	14,7	0,066
2009-07-31	02:00	4,7	7,2	7,2	10,2	230,6	81,6	11,3	15,9	0,058
2009-07-31	03:00	-99,0	-99,0	-99,0	-99,0	-99,0	-99,0	-99,0	-99,0	-99,0
2009-07-31	04:00	5,1	7,8	7,2	9,3	230,6	81,6	11,3	14,5	0,062
2009-07-31	05:00	5,2	7,9	7,6	11,6	241,9	90,7	11,9	18,1	0,058
2009-07-31	06:00	5,8	8,8	8,0	11,7	241,9	101,1	12,6	18,2	0,058
2009-07-31	07:00	5,8	8,8	8,0	10,9	236,3	101,1	12,6	17,0	0,058
2009-07-31	08:00	5,8	8,7	8,0	12,8	230,6	101,1	12,6	20,0	0,058
2009-07-31	09:00	6,2	9,3	8,5	12,8	241,9	113,4	13,3	19,9	0,055
2009-07-31	10:00	6,0	9,1	8,0	11,0	236,3	101,1	12,6	17,3	0,060

FÖRKLARING:

Hs = signifikant våghöjd (m). Medlet av den högsta 1/3 av vågor under 30 minuter.

Hmax = maximal våghöjd (m). Beräknad från Hs och Tp enligt WMO standard-formel:

$H_{max} = (1.9/2) * H_s * \text{roten_ur}(0.5 * \log(30 * 60 / T_p))$;

Tz = medelvågperiod (s). "Zero-crossing" period.

Tp = vågperiod för vågorna med störst energi (s).

ThTp = vågriktning för vågorna med störst energi (gr). Anges som varifrån vågorna kommer.

L = medelvåglängd (m). Beräknad från Tz. $L = g * T_z^2 / (2 * \pi)$

Cz = vågornas medelhastighet (m/s). Beräknad från Tz. $C_z = g * T_z / (2 * \pi)$. Korta vågor.

Cp = vågornas hastighet där vågornas energi är som störst (m/s). Beräknad från Tp.

$C_p = g * T_p / (2 * \pi)$. Korta vågor.

Hs/L = vågornas branthet.

VEDLEGG I



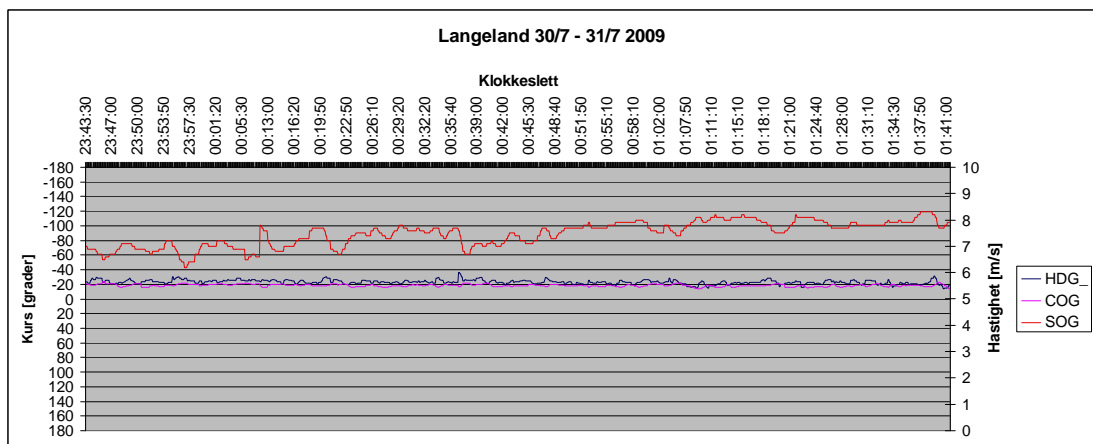
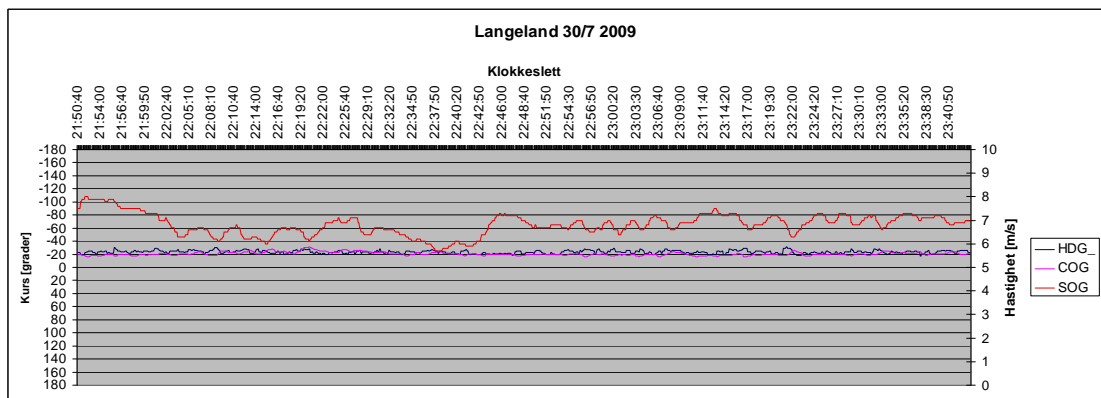
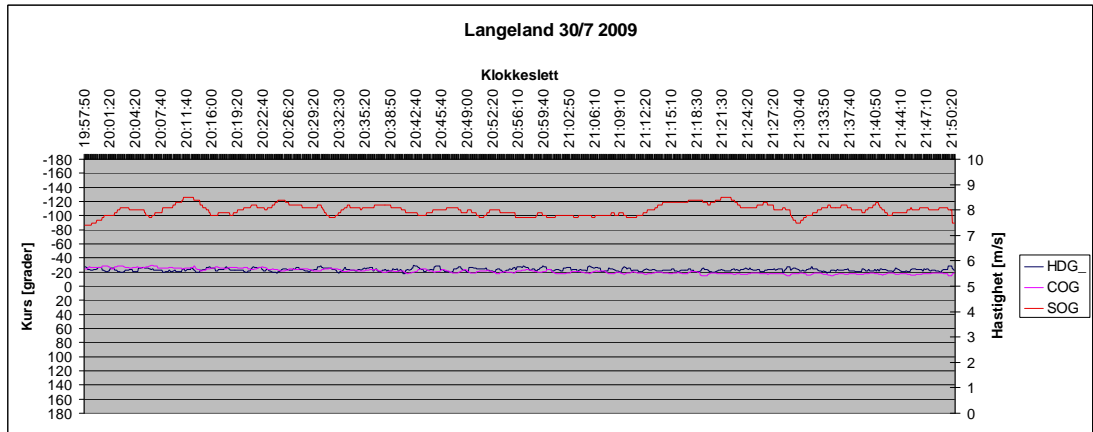

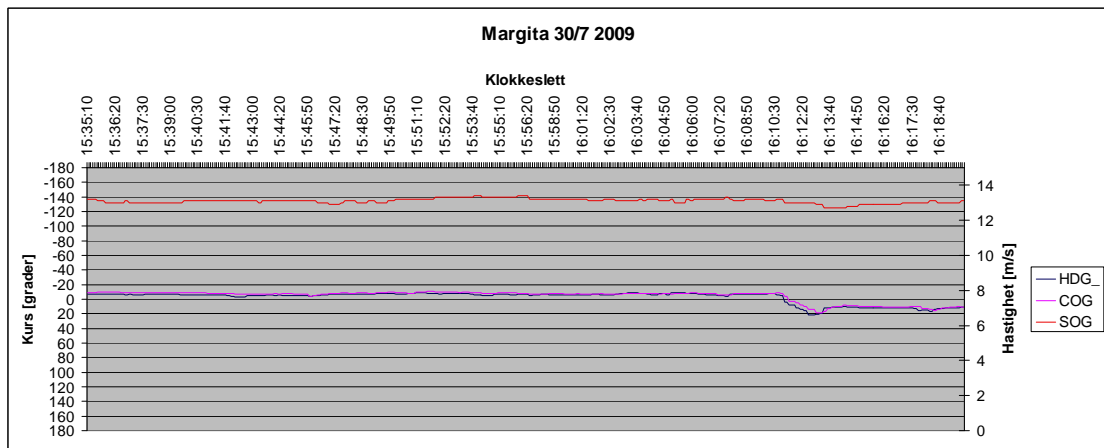
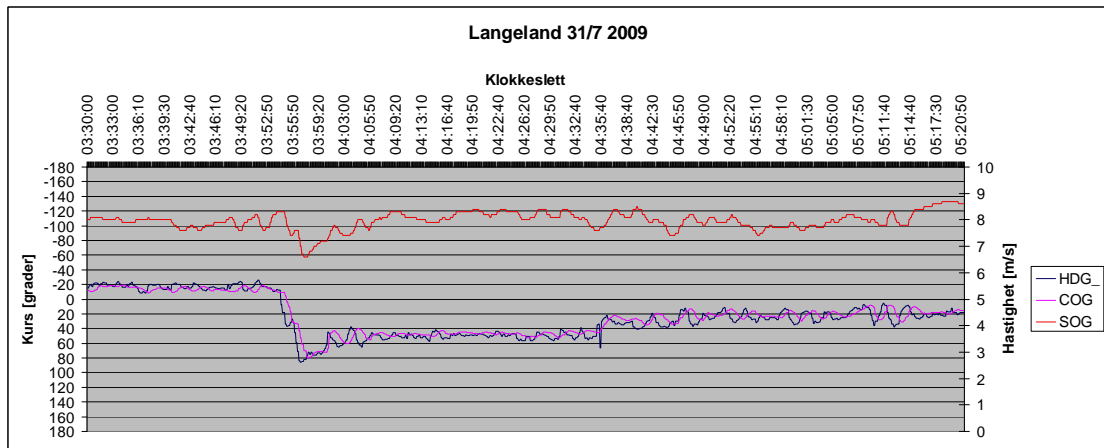
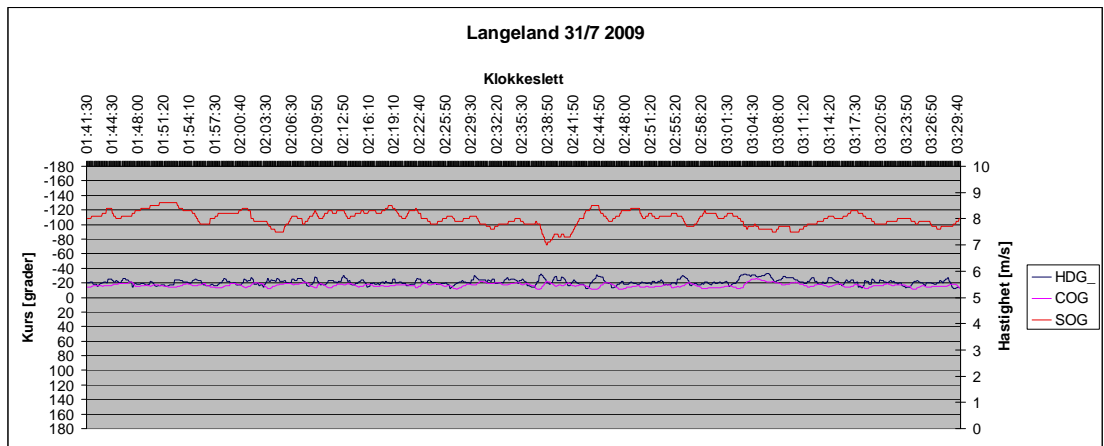

GRAFER SOM VISER HEADING, COG OG SOG

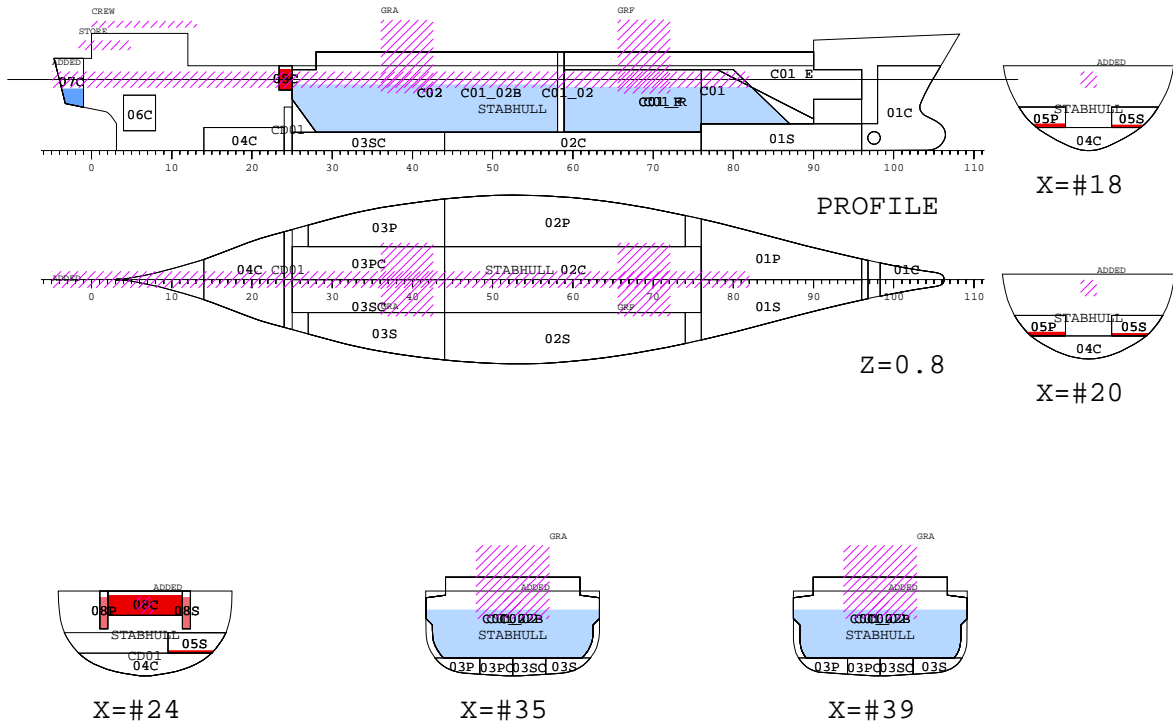



1.2 C01 - Avgang havn - Gravemaskin forut



	SEA WATER
	WATER BALLAST
	Solid cargo
	HYDRAULIC OIL
	LUBRICATING OIL
	FRESH WATER
	FUEL OIL

Mean draught (moulded)	5.40 m
Draught AP (moulded)	5.40 m
Draught FP (moulded)	5.41 m
Draught Aft (below keel, x= 0.00 m)	5.41 m
Draught Fore (below keel, x= 64.05 m)	5.42 m
Trim (by head)	0.01 m
Heeling	0.0 deg
KM above the moulded base	5.90 m
KG above the moulded base	3.86 m
GM0 (solid)	2.04 m
Free surface correction	0.04 m
GM (fluid)	2.00 m
Density of water	1.025 t/m3

	Weight	LCG	TCG	VCG
	t	m	m	m
Lightweight	831.3	28.14	0.00	5.39
Deadweight	2469.0	32.18	0.00	3.35
Total weight	3300.3	31.16	0.00	3.86

DEADWEIGHT COMPONENTS
A) LIQUIDS:

NAME	LOAD	MASS t	FILL %	LCG m	TCG m	VCG m	FRSM tm
Solid cargo	CAS	2353.0	33.8	32.67	0.00	3.26	0.0
FUEL OIL	FO	14.2	6.1	12.90	0.04	3.74	31.3
FRESH WATER	FW	13.0	12.6	0.24	0.00	4.26	87.9
LUBRICATING OIL	LO	1.6	82.8	14.95	0.00	4.78	0.0
SEA WATER	SW	0.0	0.0	0.00	0.00	0.00	0.0
WATER BALLAST	WB	0.0	0.0	0.00	0.00	0.00	0.0
SUBTOTAL		2381.7	21.7	32.36	0.00	3.27	119.1

B) LIST OF FIXED MASSES:

NAME	DES	MASS t	LCG m	TCG m	VCG m
FIXED					
CREW	Mannskap og Proviant	2.0	4.00	0.00	9.60
STORE	Stores	2.0	1.00	0.00	8.00
ADDED	LETTSKIP ØKNING	83.0	0.00	0.00	5.39
GRA	GRAVEMASKIN AKTERUT	-125.2	24.02	0.00	7.14
GRF	GRAVEMASKIN FORUT	125.5	42.78	0.00	7.14
SUBTOTAL		87.3	27.17	0.00	5.55

RELEVANT OPENINGS

NAME	X m	Y m	Z m	IMMA degree	IMMR m	REDPD m	OTYPE
O1	5.00	-2.500	11.800	-58.1	6.401	0.045	
O2	5.00	2.500	11.800	58.1	6.401	0.045	
O3	16.80	5.100	7.500	21.1	2.099	0.090	
O4	16.80	-5.100	7.500	-21.1	2.099	0.090	
O5	48.00	5.100	7.500	20.8	2.095	0.090	
O6	48.00	-5.100	7.500	-20.8	2.095	0.090	

LIST OF LOADED COMPARTMENTS

NAME	DES	MASS t	FILL %	LCG m	TCG m	VCG m	FRSM tm

CONTENTS=Solid cargo (RHO=1.6)							
C02	Aft Cargohold	1413.0	62.0	25.73	0.00	3.28	0.0
C01_F	Cargo in Fwd Cargohold	940.0	72.1	43.09	0.00	3.22	0.0

SUBTOTAL		2353.0	65.7	32.67	0.00	3.26	0.0
CONTENTS=FUEL OIL (RHO=0.86)							
05P	No.5 PS Bunkers	3.3	15.8	10.23	-2.72	1.89	6.6
05S	No.5 SB Bunkers	3.3	11.1	11.33	2.89	1.84	11.7
08C	Daytank	7.6	85.0	14.75	0.00	5.39	12.9

SUBTOTAL		14.2	23.7	12.90	0.04	3.74	31.3
CONTENTS=FRESH WATER (RHO=1)							
07C	No.7 Aft C Ballast	13.0	16.7	0.24	0.00	4.26	87.9
CONTENTS=LUBRICATING OIL (RHO=0.92)							
08S	Lub. Oil	0.8	82.8	14.95	3.14	4.78	0.0
08P	Lub. Oil	0.8	82.8	14.95	-3.14	4.78	0.0

SUBTOTAL		1.6	82.8	14.95	0.00	4.78	0.0

Loading condition C01

HEEL degree	GZ m	AREA rad*m	TR m	RESFLD m	RESFRB m
0.0	0.000	0.000	0.009	2.09	-
1.0	0.035	0.000	0.009	2.01	-
3.0	0.105	0.003	0.010	1.83	-
5.0	0.175	0.008	0.010	1.65	-
10.0	0.353	0.031	0.012	1.19	-
20.0	0.527	0.111	0.067	0.09	-
30.0	0.619	0.211	0.168	-1.13	-
40.0	0.650	0.323	0.241	-2.41	-
50.0	0.610	0.434	0.264	-3.68	-
60.0	0.513	0.532	0.247	-4.86	-

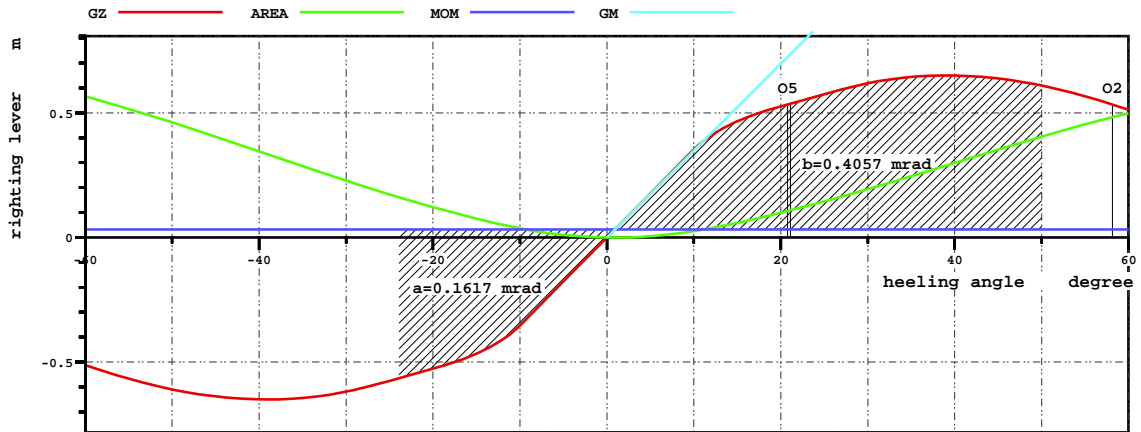





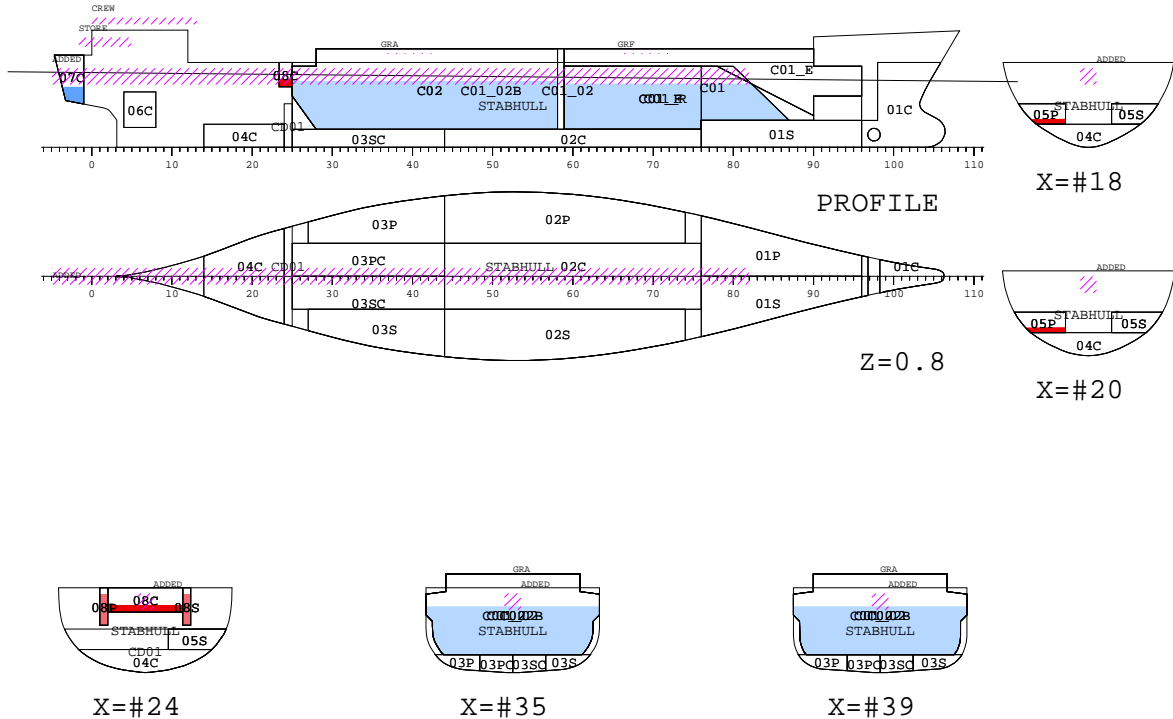

INTACT CRITERIA STATUS

RCR	TEXT	REQ	ATTV	MARGIN	UNIT	STAT
AREA30	GZ Area up to 30 deg.	0.055	0.211	0.156	mrاد	OK
AREA40	GZ Area up to 40 deg.	0.090	0.323	0.233	mrاد	OK
AREA3040	Minarea 30-40deg	0.030	0.112	0.082	mrاد	OK
GZ0.2	Max GZ > 0.2	0.200	0.650	0.450	m	OK
MAXGZ25	Max GZ at angle > 25deg	25.000	39.020	14.019	deg	OK
GM0.15	GM > 0.15 m	0.150	2.001	1.851	m	OK
IMOWEATHER	IMO weather crit.	1.000	2.509	1.509		OK

1.3 C02 - Lastekondisjon før forlis - Gravemaskin akterut



	SEA WATER
	WATER BALLAST
	Solid cargo
	HYDRAULIC OIL
	LUBRICATING OIL
	FRESH WATER
	FUEL OIL

Mean draught (moulded)	5.36 m
Draught AP (moulded)	5.69 m
Draught FP (moulded)	5.04 m
Draught Aft (below keel, x= 0.00 m)	5.70 m
Draught Fore (below keel, x= 64.05 m)	5.05 m
Trim (by stern)	-0.64 m
Heeling to port side	-0.1 deg
KM above the moulded base	5.91 m
KG above the moulded base	3.86 m
GM0 (solid)	2.05 m
Free surface correction	0.03 m
GM (fluid)	2.01 m
Density of water	1.025 t/m ³

	Weight t	LCG m	TCG m	VCG m
Lightweight	831.3	28.14	0.00	5.39
Deadweight	2460.3	31.30	0.00	3.34
Total weight	3291.6	30.50	0.00	3.86

DEADWEIGHT COMPONENTS
A) LIQUIDS:

NAME	LOAD	MASS t	FILL %	LCG m	TCG m	VCG m	FRSM tm
Solid cargo	CAS	2353.0	33.8	32.67	0.00	3.26	0.0
FUEL OIL	FO	7.7	3.3	11.78	-1.24	2.89	29.9
FRESH WATER	FW	11.0	10.6	0.26	0.00	4.19	77.5
LUBRICATING OIL	LO	1.6	82.8	14.95	0.00	4.78	0.0
SEA WATER	SW	0.0	0.0	0.00	0.00	0.00	0.0
WATER BALLAST	WB	0.0	0.0	0.00	0.00	0.00	0.0
SUBTOTAL		2373.3	21.6	32.44	0.00	3.26	107.4

B) LIST OF FIXED MASSES:

NAME	DES	MASS t	LCG m	TCG m	VCG m
FIXED					
CREW	Mannskap og Proviant	2.0	4.00	0.00	9.60
STORE	Stores	2.0	1.00	0.00	8.00
ADDED	LETTSKIP ØKNING	83.0	0.00	0.00	5.39
SUBTOTAL		87.0	0.11	0.00	5.55

RELEVANT OPENINGS

NAME	X m	Y m	Z m	IMMA degree	IMMR m	REDPD m	OTYPE
O1	5.00	-2.500	11.800	-55.6	6.161	0.046	
O2	5.00	2.500	11.800	55.6	6.164	0.045	
O3	16.80	5.100	7.500	20.0	1.983	0.090	
O4	16.80	-5.100	7.500	-20.0	1.975	0.090	
O5	48.00	5.100	7.500	22.7	2.296	0.090	
O6	48.00	-5.100	7.500	-22.7	2.288	0.090	

LIST OF LOADED COMPARTMENTS

NAME	DES	MASS t	FILL %	LCG m	TCG m	VCG m	FRSM tm

CONTENTS=Solid cargo (RHO=1.6)							
C02	Aft Cargohold	1413.0	62.0	25.73	0.00	3.28	0.0
C01_F	Cargo in Fwd Cargohold	940.0	72.1	43.09	0.00	3.22	0.0

SUBTOTAL		2353.0	65.7	32.67	0.00	3.26	0.0
CONTENTS=FUEL OIL (RHO=0.86)							
05P	No.5 PS Bunkers	4.3	20.6	10.25	-2.76	1.94	7.4
05S	No.5 SB Bunkers	0.9	2.9	10.54	2.64	1.71	9.6
08C	Daytank	2.6	29.0	14.75	0.00	4.87	12.9

SUBTOTAL		7.7	13.0	11.78	-1.24	2.89	29.9
CONTENTS=FRESH WATER (RHO=1)							
07C	No.7 Aft C Ballast	11.0	14.1	0.26	0.00	4.19	77.5
CONTENTS=LUBRICATING OIL (RHO=0.92)							
08S	Lub. Oil	0.8	82.8	14.95	3.14	4.78	0.0
08P	Lub. Oil	0.8	82.8	14.95	-3.14	4.78	0.0

SUBTOTAL		1.6	82.8	14.95	0.00	4.78	0.0

Loading condition C02

HEEL degree	GZ m	AREA rad*m	TR m	RESFLD m	RESFRB m
0.0	-0.003	0.000	-0.642	1.98	-
0.1	0.000	0.000	-0.642	1.98	-
1.0	0.032	0.000	-0.642	1.89	-
3.0	0.103	0.003	-0.641	1.71	-
5.0	0.174	0.007	-0.639	1.53	-
10.0	0.350	0.030	-0.640	1.08	-
20.0	0.534	0.111	-0.658	0.00	-
30.0	0.627	0.212	-0.595	-1.19	-
40.0	0.655	0.326	-0.618	-2.46	-
50.0	0.615	0.437	-0.689	-3.74	-
60.0	0.516	0.537	-0.770	-4.95	-

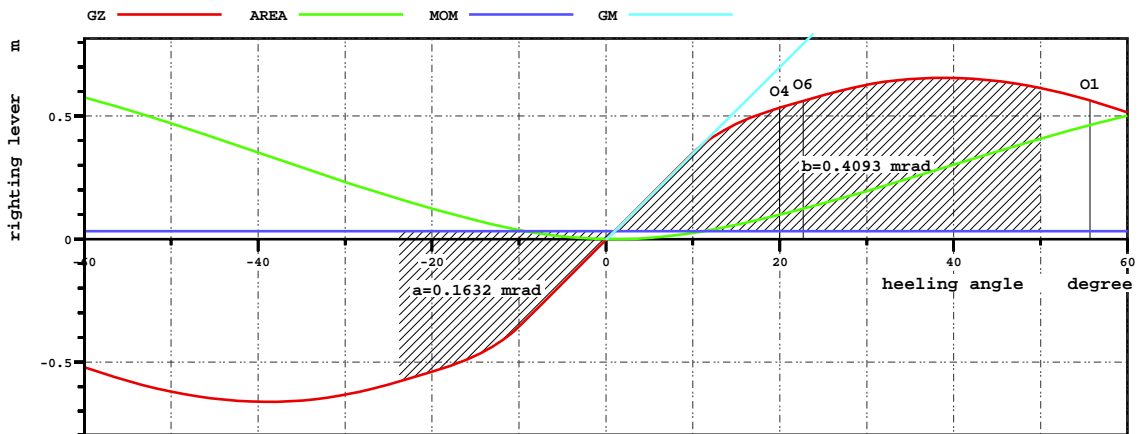





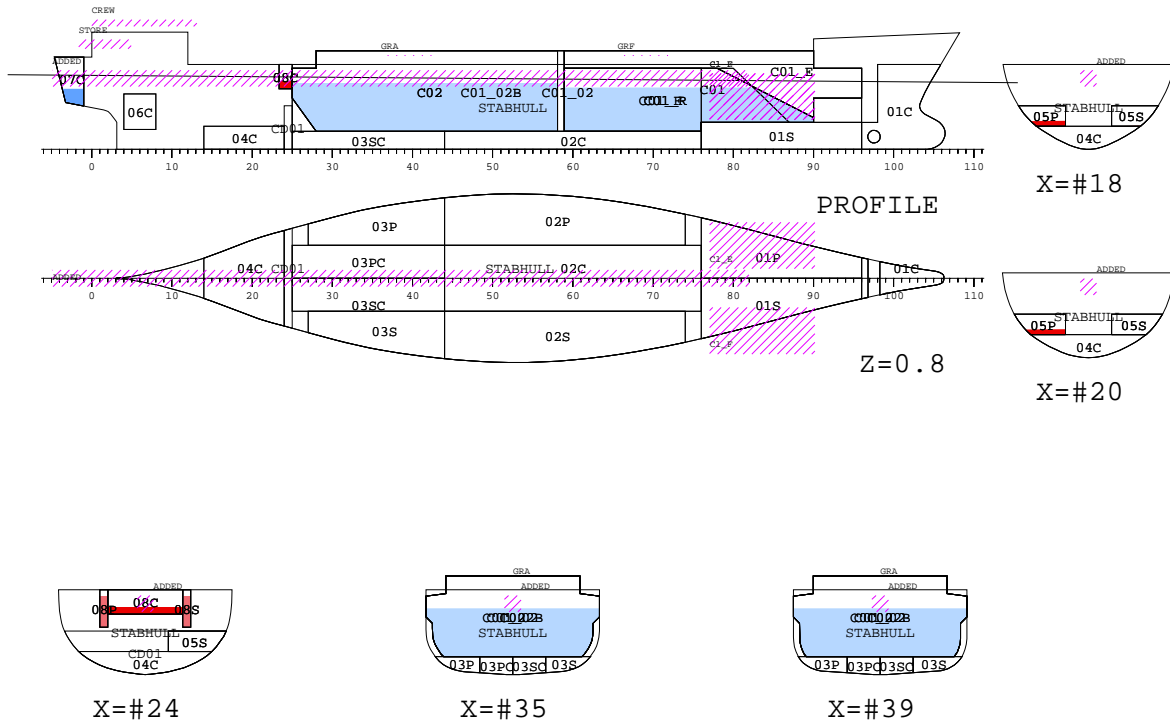

INTACT CRITERIA STATUS

RCR	TEXT	REQ	ATTV	MARGIN	UNIT	STAT
AREA30	GZ Area up to 30 deg.	0.055	0.212	0.157	mrad	OK
AREA40	GZ Area up to 40 deg.	0.090	0.326	0.236	mrad	OK
AREA3040	Minarea 30-40deg	0.030	0.113	0.083	mrad	OK
GZ0.2	Max GZ > 0.2	0.200	0.656	0.456	m	OK
MAXGZ25	Max GZ at angle > 25deg	25.000	38.761	13.761	deg	OK
GM0.15	GM > 0.15 m	0.150	2.013	1.863	m	OK
IMOWEATHER	IMO weather crit.	1.000	2.508	1.508		OK

1.4 C03 - Last i forre rom raser ut



	SEA WATER
	WATER BALLAST
	Solid cargo
	HYDRAULIC OIL
	LUBRICATING OIL
	FRESH WATER
	FUEL OIL

Mean draught (moulded)	5.34 m
Draught AP (moulded)	5.60 m
Draught FP (moulded)	5.08 m
Draught Aft (below keel, x= 0.00 m)	5.61 m
Draught Fore (below keel, x= 64.05 m)	5.09 m
Trim (by stern)	-0.52 m
Heeling to port side	-5.6 deg
KM above the moulded base	5.90 m
KG above the moulded base	3.84 m
GM0 (solid)	2.07 m
Free surface correction	0.03 m
GM (fluid)	2.03 m
Density of water	1.025 t/m ³

	Weight t	LCG m	TCG m	VCG m
Lightweight	831.3	28.14	0.00	5.39
Deadweight	2460.3	31.46	-0.27	3.31
Total weight	3291.6	30.62	-0.20	3.84

DEADWEIGHT COMPONENTS
A) LIQUIDS:

NAME	LOAD	MASS t	FILL %	LCG m	TCG m	VCG m	FRSM tm
Solid cargo	CAS	2353.0	33.8	32.84	0.00	3.23	0.0
FUEL OIL	FO	7.7	3.3	11.78	-1.24	2.89	29.9
FRESH WATER	FW	11.0	10.6	0.26	0.00	4.19	77.5
LUBRICATING OIL	LO	1.6	82.8	14.95	0.00	4.78	0.0
SEA WATER	SW	0.0	0.0	0.00	0.00	0.00	0.0
WATER BALLAST	WB	0.0	0.0	0.00	0.00	0.00	0.0
SUBTOTAL		2373.3	21.6	32.61	0.00	3.23	107.4

B) LIST OF FIXED MASSES:

NAME	DES	MASS t	LCG m	TCG m	VCG m
FIXED					
CREW	Mannskap og Proviant	2.0	4.00	0.00	9.60
STORE	Stores	2.0	1.00	0.00	8.00
ADDED	LETTSKIP ØKNING	83.0	0.00	0.00	5.39
C1_F	LAST FØR UTRASING	-100.0	51.00	4.00	4.00
C1_E	LAST ETTER UTRASING	100.0	51.00	-2.50	4.00
SUBTOTAL		87.0	0.11	-7.47	5.55

RELEVANT OPENINGS

NAME	X m	Y m	Z m	IMMA degree	IMMR m	REDPD m	OTYPE
O1	5.00	-2.500	11.800	-56.1	5.942	0.065	
O2	5.00	2.500	11.800	56.1	-	-	
O3	16.80	5.100	7.500	20.2	-	-	
O4	16.80	-5.100	7.500	-20.2	1.504	0.102	
O5	48.00	5.100	7.500	22.3	-	-	
O6	48.00	-5.100	7.500	-22.3	1.756	0.102	

LIST OF LOADED COMPARTMENTS

NAME	DES	MASS t	FILL %	LCG m	TCG m	VCG m	FRSM tm

CONTENTS=Solid cargo (RHO=1.6)							
C02	Aft Cargohold	1413.0	62.0	25.73	0.00	3.28	0.0
C01_R	Forskjøvet last i forre.	940.0	70.7	43.53	0.00	3.15	0.0

SUBTOTAL		2353.0	65.2	32.84	0.00	3.23	0.0
CONTENTS=FUEL OIL (RHO=0.86)							
05P	No.5 PS Bunkers	4.3	20.6	10.25	-2.76	1.94	7.4
05S	No.5 SB Bunkers	0.9	2.9	10.54	2.64	1.71	9.6
08C	Daytank	2.6	29.0	14.75	0.00	4.87	12.9

SUBTOTAL		7.7	13.0	11.78	-1.24	2.89	29.9
CONTENTS=FRESH WATER (RHO=1)							
07C	No.7 Aft C Ballast	11.0	14.1	0.26	0.00	4.19	77.5
CONTENTS=LUBRICATING OIL (RHO=0.92)							
08S	Lub. Oil	0.8	82.8	14.95	3.14	4.78	0.0
08P	Lub. Oil	0.8	82.8	14.95	-3.14	4.78	0.0

SUBTOTAL		1.6	82.8	14.95	0.00	4.78	0.0

Loading condition C03

HEEL degree	GZ m	AREA rad*m	TR m	RESFLD m	RESFRB m
0.0	-0.200	0.000	-0.520	2.01	-
1.0	-0.165	-0.003	-0.520	1.92	-
3.0	-0.094	-0.008	-0.519	1.74	-
5.0	-0.021	-0.010	-0.517	1.56	-
5.6	0.000	-0.010	-0.516	1.50	-
10.0	0.160	-0.004	-0.516	1.10	-
20.0	0.355	0.044	-0.521	0.02	-
30.0	0.467	0.117	-0.449	-1.16	-
40.0	0.518	0.203	-0.453	-2.42	-
50.0	0.505	0.294	-0.508	-3.70	-
60.0	0.436	0.376	-0.576	-4.91	-

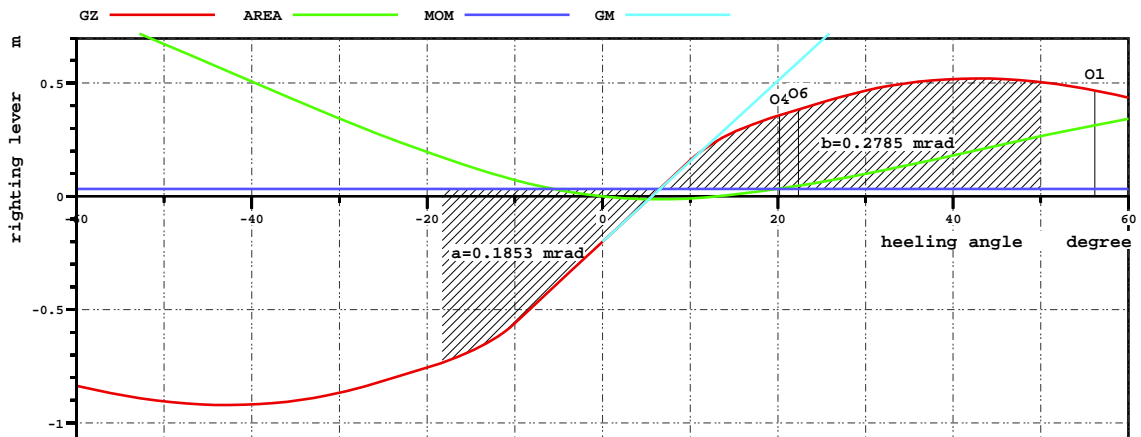

INTACT CRITERIA STATUS

RCR	TEXT	REQ	ATTV	MARGIN	UNIT	STAT
AREA30	GZ Area up to 30 deg.	0.055	0.126	0.071	mrad	OK
AREA40	GZ Area up to 40 deg.	0.090	0.213	0.123	mrad	OK
AREA3040	Minarea 30-40deg	0.030	0.087	0.057	mrad	OK
GZ0.2	Max GZ > 0.2	0.200	0.520	0.320	m	OK
MAXGZ25	Max GZ at angle > 25deg	25.000	42.886	17.886	deg	OK
GM0.15	GM > 0.15 m	0.150	2.032	1.882	m	OK
IMOWEATHER	IMO weather crit.	1.000	1.503	0.503		OK

1.5 C04 - Forskjøvet last + 200t sjøvann i rommene

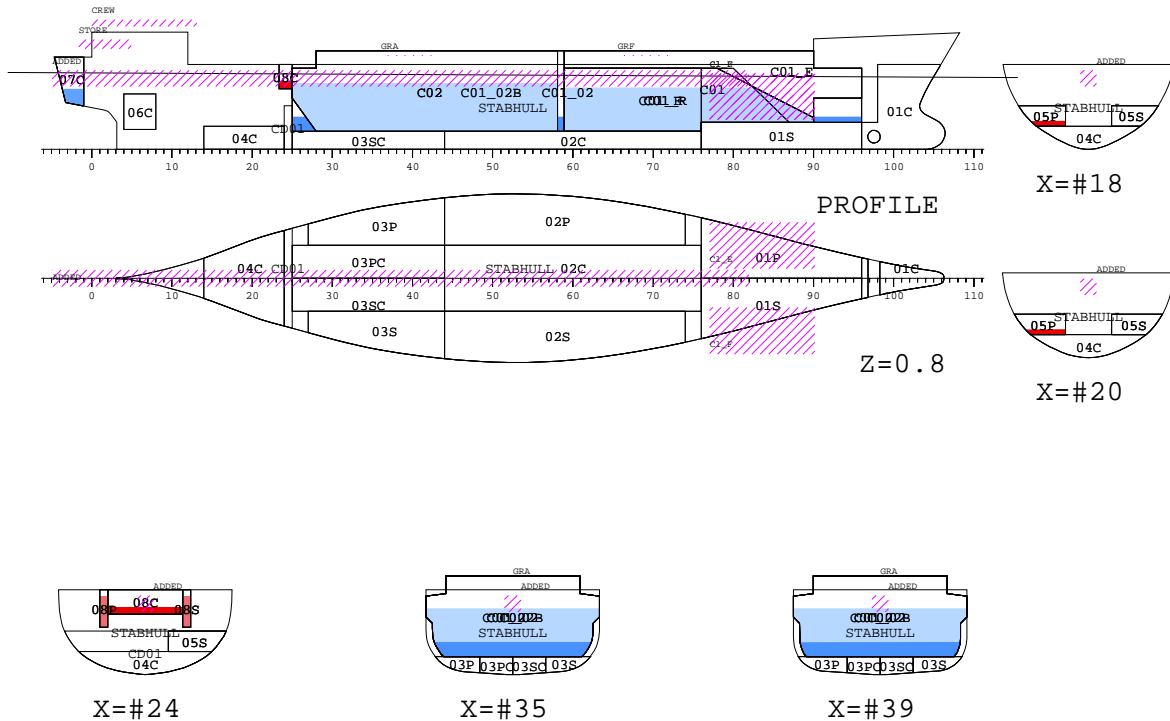

SEA WATER
WATER BALLAST
Solid cargo
HYDRAULIC OIL
LUBRICATING OIL
FRESH WATER
FUEL OIL

Mean draught (moulded)	5.59 m
Draught AP (moulded)	5.75 m
Draught FP (moulded)	5.43 m
Draught Aft (below keel, x= 0.00 m)	5.76 m
Draught Fore (below keel, x= 64.05 m)	5.44 m
Trim (by stern)	-0.32 m
Heeling to port side	-7.0 deg
KM above the moulded base	5.93 m
KG above the moulded base	3.73 m
GM0 (solid)	2.20 m
Free surface correction	0.67 m
GM (fluid)	1.53 m
Density of water	1.025 t/m3

	Weight t	LCG m	TCG m	VCG m
Lightweight	831.3	28.14	0.00	5.39
Deadweight	2660.3	31.56	-0.25	3.21
Total weight	3491.6	30.74	-0.19	3.73

DEADWEIGHT COMPONENTS

A) LIQUIDS:

NAME	LOAD	MASS t	FILL %	LCG m	TCG m	VCG m	FRSM tm
Solid cargo	CAS	2353.0	33.8	32.84	0.00	3.23	0.0
FUEL OIL	FO	7.7	3.3	11.78	-1.24	2.89	29.9
FRESH WATER	FW	11.0	10.6	0.26	0.00	4.19	77.5
LUBRICATING OIL	LO	1.6	82.8	14.95	0.00	4.78	0.0
SEA WATER	SW	200.0	11.5	32.73	0.00	1.96	2245.9
WATER BALLAST	WB	0.0	0.0	0.00	0.00	0.00	0.0
SUBTOTAL		2573.3	24.4	32.62	0.00	3.13	2353.3

B) LIST OF FIXED MASSES:

NAME	DES	MASS t	LCG m	TCG m	VCG m
FIXED					
CREW	Mannskap og Proviant	2.0	4.00	0.00	9.60
STORE	Stores	2.0	1.00	0.00	8.00
ADDED	LETTSKIP ØKNING	83.0	0.00	0.00	5.39
Cl_F	LAST FØR UTRASING	-100.0	51.00	4.00	4.00
Cl_E	LAST ETTER UTRASING	100.0	51.00	-2.50	4.00
SUBTOTAL		87.0	0.11	-7.47	5.55

RELEVANT OPENINGS

NAME	X m	Y m	Z m	IMMA degree	IMMR m	REDPD m	OTYPE
O1	5.00	-2.500	11.800	-53.6	5.686	0.070	
O2	5.00	2.500	11.800	53.6	-	-	
O3	16.80	5.100	7.500	17.7	-	-	
O4	16.80	-5.100	7.500	-17.7	1.162	0.105	
O5	48.00	5.100	7.500	19.0	-	-	
O6	48.00	-5.100	7.500	-19.0	1.317	0.105	

LIST OF LOADED COMPARTMENTS

NAME	DES	MASS t	FILL %	LCG m	TCG m	VCG m	FRSM tm

CONTENTS=Solid cargo (RHO=1.6)							
C02	Aft Cargohold	1413.0	62.0	25.73	0.00	3.28	0.0
C01_R	Forskjøvet last i forre.	940.0	70.7	43.53	0.00	3.15	0.0

SUBTOTAL		2353.0	65.2	32.84	0.00	3.23	0.0
CONTENTS=FUEL OIL (RHO=0.86)							
05P	No.5 PS Bunkers	4.3	20.6	10.25	-2.76	1.94	7.4
05S	No.5 SB Bunkers	0.9	2.9	10.54	2.64	1.71	9.6
08C	Daytank	2.6	29.0	14.75	0.00	4.87	12.9

SUBTOTAL		7.7	13.0	11.78	-1.24	2.89	29.9
CONTENTS=FRESH WATER (RHO=1)							
07C	No.7 Aft C Ballast	11.0	14.1	0.26	0.00	4.19	77.5
CONTENTS=LUBRICATING OIL (RHO=0.92)							
08S	Lub. Oil	0.8	82.8	14.95	3.14	4.78	0.0
08P	Lub. Oil	0.8	82.8	14.95	-3.14	4.78	0.0

SUBTOTAL		1.6	82.8	14.95	0.00	4.78	0.0
CONTENTS=SEA WATER (RHO=1.025)							
C01_02	Seawater in both cargo h.	200.0	15.5	32.73	0.00	1.96	2245.9

Loading condition C04

HEEL degree	GZ m	AREA rad*m	TR m	RESFLD m	RESFRB m
0.0	-0.189	0.000	-0.319	1.79	-
1.0	-0.162	-0.003	-0.319	1.70	-
3.0	-0.108	-0.008	-0.319	1.52	-
5.0	-0.054	-0.011	-0.319	1.34	-
7.0	0.000	-0.012	-0.320	1.16	-
10.0	0.060	-0.010	-0.340	0.86	-
20.0	0.145	0.008	-0.311	-0.27	-
30.0	0.224	0.041	-0.267	-1.50	-
40.0	0.258	0.083	-0.302	-2.80	-
50.0	0.262	0.129	-0.369	-4.11	-
60.0	0.238	0.173	-0.451	-5.36	-

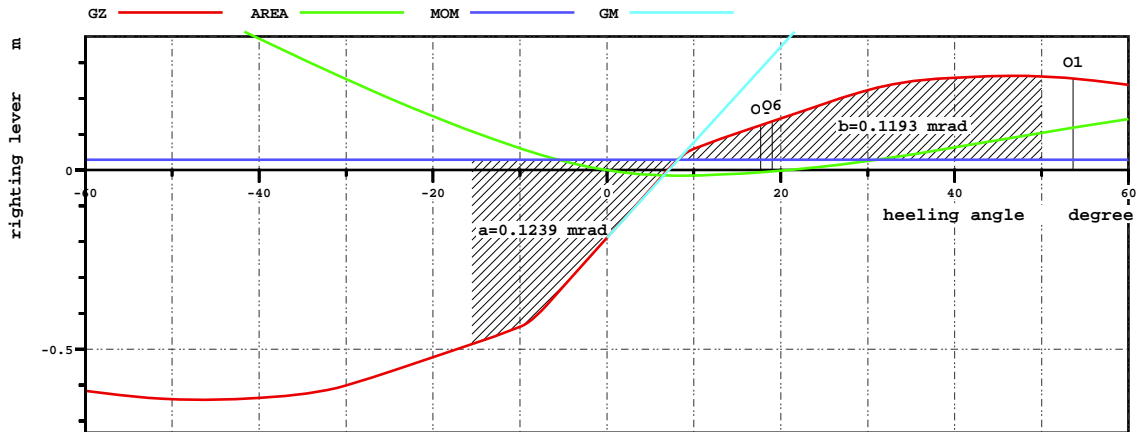

INTACT CRITERIA STATUS

RCR	TEXT	REQ	ATTV	MARGIN	UNIT	STAT
AREA30	GZ Area up to 30 deg.	0.055	0.052	0.003	mrad	NOT .
AREA40	GZ Area up to 40 deg.	0.090	0.095	0.005	mrad	OK
AREA3040	Minarea 30-40deg	0.030	0.043	0.013	mrad	OK
GZ0.2	Max GZ > 0.2	0.200	0.263	0.063	m	OK
MAXGZ25	Max GZ at angle > 25deg	25.000	46.792	21.792	deg	OK
GM0.15	GM > 0.15 m	0.150	1.529	1.379	m	OK
IMOWEATHER	IMO weather crit.	1.000	0.963	0.037		NOT .

1.6 C05 - Forskjøvet last + 400t sjøvann i rommene

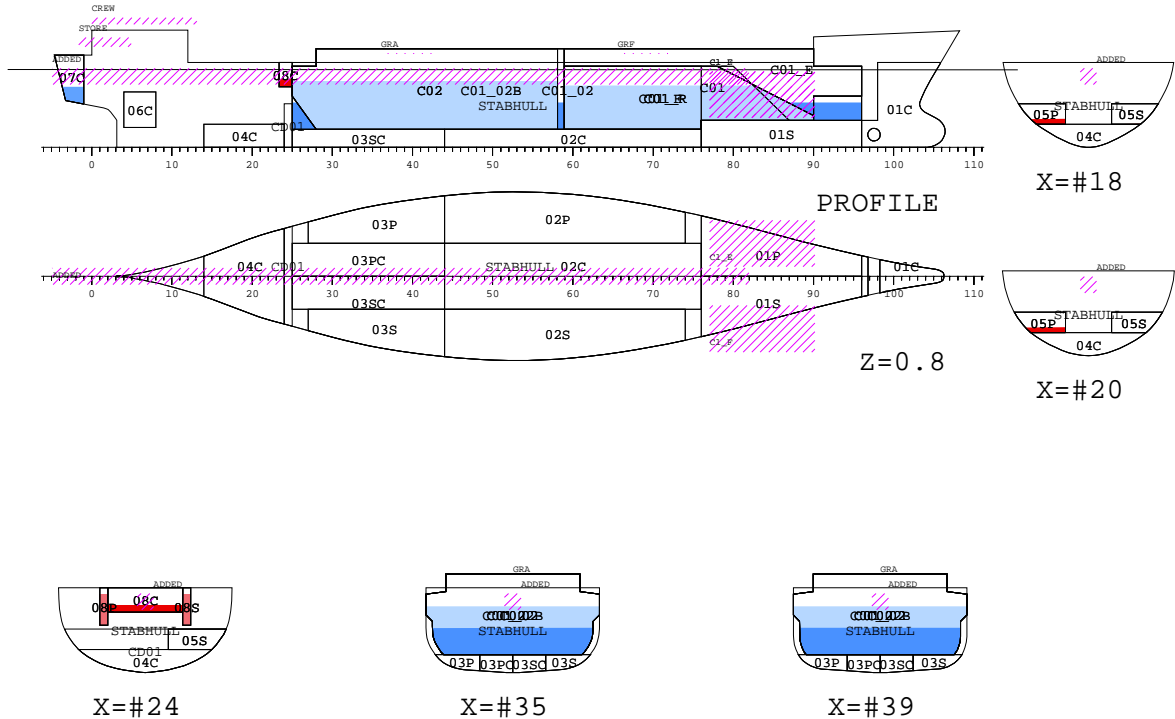

SEA WATER
WATER BALLAST
Solid cargo
HYDRAULIC OIL
LUBRICATING OIL
FRESH WATER
FUEL OIL

Mean draught (moulded)	5.87 m
Draught AP (moulded)	5.88 m
Draught FP (moulded)	5.86 m
Draught Aft (below keel, x= 0.00 m)	5.89 m
Draught Fore (below keel, x= 64.05 m)	5.87 m
Trim (by stern)	-0.02 m
Heeling to port side	-7.2 deg
KM above the moulded base	5.98 m
KG above the moulded base	3.69 m
GM0 (solid)	2.29 m
Free surface correction	0.69 m
GM (fluid)	1.60 m
Density of water	1.025 t/m ³

	Weight t	LCG m	TCG m	VCG m
Lightweight	831.3	28.14	0.00	5.39
Deadweight	2860.3	31.80	-0.23	3.19
Total weight	3691.6	30.97	-0.18	3.69

DEADWEIGHT COMPONENTS
A) LIQUIDS:

NAME	LOAD	MASS t	FILL %	LCG m	TCG m	VCG m	FRSM tm
Solid cargo	CAS	2353.0	33.8	32.84	0.00	3.23	0.0
FUEL OIL	FO	7.7	3.3	11.78	-1.24	2.89	29.9
FRESH WATER	FW	11.0	10.6	0.26	0.00	4.19	77.5
LUBRICATING OIL	LO	1.6	82.8	14.95	0.00	4.78	0.0
SEA WATER	SW	400.0	22.9	33.85	0.00	2.45	2436.4
WATER BALLAST	WB	0.0	0.0	0.00	0.00	0.00	0.0
SUBTOTAL		2773.3	27.2	32.79	0.00	3.12	2543.9

B) LIST OF FIXED MASSES:

NAME	DES	MASS t	LCG m	TCG m	VCG m
FIXED					
CREW	Mannskap og Proviant	2.0	4.00	0.00	9.60
STORE	Stores	2.0	1.00	0.00	8.00
ADDED	LETTSKIP ØKNING	83.0	0.00	0.00	5.39
C1_F	LAST FØR UTRASING	-100.0	51.00	4.00	4.00
C1_E	LAST ETTER UTRASING	100.0	51.00	-2.50	4.00
SUBTOTAL		87.0	0.11	-7.47	5.55

RELEVANT OPENINGS

NAME	X m	Y m	Z m	IMMA degree	IMMR m	REDPD m	OTYPE
O1	5.00	-2.500	11.800	-51.6	5.515	0.071	
O2	5.00	2.500	11.800	51.6	-	-	
O3	16.80	5.100	7.500	15.3	-	-	
O4	16.80	-5.100	7.500	-15.3	0.927	0.106	
O5	48.00	5.100	7.500	15.2	-	-	
O6	48.00	-5.100	7.500	-15.2	0.936	0.106	

LIST OF LOADED COMPARTMENTS

NAME	DES	MASS t	FILL %	LCG m	TCG m	VCG m	FRSM tm

CONTENTS=Solid cargo (RHO=1.6)							
C02	Aft Cargohold	1413.0	62.0	25.73	0.00	3.28	0.0
C01_R	Forskjøvet last i forre.	940.0	70.7	43.53	0.00	3.15	0.0

SUBTOTAL		2353.0	65.2	32.84	0.00	3.23	0.0
CONTENTS=FUEL OIL (RHO=0.86)							
05P	No.5 PS Bunkers	4.3	20.6	10.25	-2.76	1.94	7.4
05S	No.5 SB Bunkers	0.9	2.9	10.54	2.64	1.71	9.6
08C	Daytank	2.6	29.0	14.75	0.00	4.87	12.9

SUBTOTAL		7.7	13.0	11.78	-1.24	2.89	29.9
CONTENTS=FRESH WATER (RHO=1)							
07C	No.7 Aft C Ballast	11.0	14.1	0.26	0.00	4.19	77.5
CONTENTS=LUBRICATING OIL (RHO=0.92)							
08S	Lub. Oil	0.8	82.8	14.95	3.14	4.78	0.0
08P	Lub. Oil	0.8	82.8	14.95	-3.14	4.78	0.0

SUBTOTAL		1.6	82.8	14.95	0.00	4.78	0.0
CONTENTS=SEA WATER (RHO=1.025)							
C01_02	Seawater in both cargo h.	400.0	31.1	33.85	0.00	2.45	2436.4

Loading condition C05

HEEL degree	GZ m	AREA rad*m	TR m	RESFLD m	RESFRB m
0.0	-0.179	0.000	-0.012	1.59	-
1.0	-0.151	-0.003	-0.012	1.50	-
3.0	-0.094	-0.007	-0.014	1.32	-
5.0	-0.038	-0.009	-0.016	1.14	-
7.2	0.000	-0.010	-0.018	0.93	-
10.0	0.017	-0.010	-0.009	0.62	-
20.0	0.021	-0.006	0.056	-0.60	-
30.0	0.048	0.000	0.101	-1.88	-
40.0	0.068	0.010	0.072	-3.20	-
50.0	0.070	0.022	0.008	-4.51	-
60.0	0.064	0.034	0.007	-5.77	-

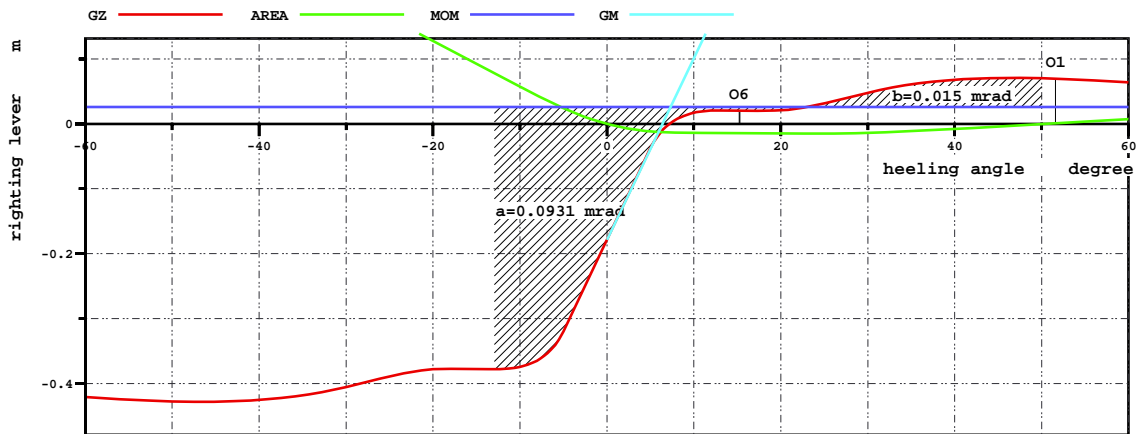

INTACT CRITERIA STATUS

RCR	TEXT	REQ	ATTV	MARGIN	UNIT	STAT
AREA30	GZ Area up to 30 deg.	0.055	0.010	0.045	mrad	NOT .
AREA40	GZ Area up to 40 deg.	0.090	0.020	0.070	mrad	NOT .
AREA3040	Minarea 30-40deg	0.030	0.010	0.020	mrad	NOT .
GZ0.2	Max GZ > 0.2	0.200	0.071	0.129	m	NOT .
MAXGZ25	Max GZ at angle > 25deg	25.000	46.635	21.635	deg	OK
GM0.15	GM > 0.15 m	0.150	1.602	1.452	m	OK
IMOWEATHER	IMO weather crit.	1.000	0.161	0.839		NOT .

1.7 C06 - Lukekarm neddykkes - 445t sjøvann i rommene

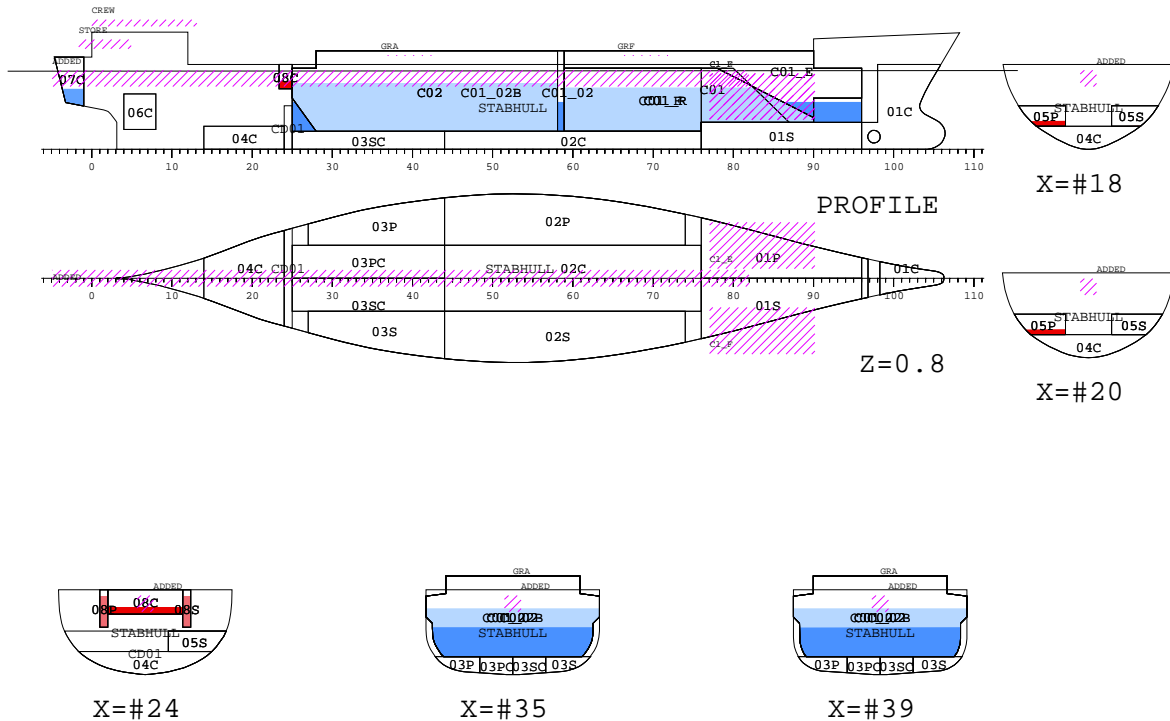

	SEA WATER
	WATER BALLAST
	Solid cargo
	HYDRAULIC OIL
	LUBRICATING OIL
	FRESH WATER
	FUEL OIL

Mean draught (moulded)	5.95 m
Draught AP (moulded)	5.92 m
Draught FP (moulded)	5.99 m
Draught Aft (below keel, x= 0.00 m)	5.93 m
Draught Fore (below keel, x= 64.05 m)	6.00 m
Trim (by head)	0.07 m
Heeling to port side	-9.5 deg
KM above the moulded base	5.99 m
KG above the moulded base	3.69 m
GM0 (solid)	2.31 m
Free surface correction	0.69 m
GM (fluid)	1.62 m
Density of water	1.025 t/m3

	Weight t	LCG m	TCG m	VCG m
Lightweight	831.3	28.14	0.00	5.39
Deadweight	2905.3	31.85	-0.23	3.20
Total weight	3736.6	31.02	-0.18	3.69

DEADWEIGHT COMPONENTS

A) LIQUIDS:

NAME	LOAD	MASS t	FILL %	LCG m	TCG m	VCG m	FRSM tm
Solid cargo	CAS	2353.0	33.8	32.84	0.00	3.23	0.0
FUEL OIL	FO	7.7	3.3	11.78	-1.24	2.89	29.9
FRESH WATER	FW	11.0	10.6	0.26	0.00	4.19	77.5
LUBRICATING OIL	LO	1.6	82.8	14.95	0.00	4.78	0.0
SEA WATER	SW	445.0	25.5	33.98	0.00	2.56	2463.7
WATER BALLAST	WB	0.0	0.0	0.00	0.00	0.00	0.0
SUBTOTAL		2818.3	27.8	32.83	0.00	3.13	2571.1

B) LIST OF FIXED MASSES:

NAME	DES	MASS t	LCG m	TCG m	VCG m
FIXED					
CREW	Mannskap og Proviant	2.0	4.00	0.00	9.60
STORE	Stores	2.0	1.00	0.00	8.00
ADDED	LETTSKIP ØKNING	83.0	0.00	0.00	5.39
C1_F	LAST FØR UTRASING	-100.0	51.00	4.00	4.00
C1_E	LAST ETTER UTRASING	100.0	51.00	-2.50	4.00
SUBTOTAL		87.0	0.11	-7.47	5.55

RELEVANT OPENINGS

NAME	X m	Y m	Z m	IMMA degree	IMMR m	REDPD m	OTYPE
O1	5.00	-2.500	11.800	-51.2	5.313	0.078	
O2	5.00	2.500	11.800	51.2	-	-	
O3	16.80	5.100	7.500	14.8	-	-	
O4	16.80	-5.100	7.500	-14.8	0.634	0.110	
O5	48.00	5.100	7.500	14.3	-	-	
O6	48.00	-5.100	7.500	-14.3	0.601	0.110	

LIST OF LOADED COMPARTMENTS

NAME	DES	MASS t	FILL %	LCG m	TCG m	VCG m	FRSM tm

CONTENTS=Solid cargo (RHO=1.6)							
C02	Aft Cargohold	1413.0	62.0	25.73	0.00	3.28	0.0
C01_R	Forskjøvet last i forre.	940.0	70.7	43.53	0.00	3.15	0.0

SUBTOTAL		2353.0	65.2	32.84	0.00	3.23	0.0
CONTENTS=FUEL OIL (RHO=0.86)							
05P	No.5 PS Bunkers	4.3	20.6	10.25	-2.76	1.94	7.4
05S	No.5 SB Bunkers	0.9	2.9	10.54	2.64	1.71	9.6
08C	Daytank	2.6	29.0	14.75	0.00	4.87	12.9

SUBTOTAL		7.7	13.0	11.78	-1.24	2.89	29.9
CONTENTS=FRESH WATER (RHO=1)							
07C	No.7 Aft C Ballast	11.0	14.1	0.26	0.00	4.19	77.5
CONTENTS=LUBRICATING OIL (RHO=0.92)							
08S	Lub. Oil	0.8	82.8	14.95	3.14	4.78	0.0
08P	Lub. Oil	0.8	82.8	14.95	-3.14	4.78	0.0

SUBTOTAL		1.6	82.8	14.95	0.00	4.78	0.0
CONTENTS=SEA WATER (RHO=1.025)							
C01_02	Seawater in both cargo h.	445.0	34.5	33.98	0.00	2.56	2463.7

Loading condition C06

HEEL degree	GZ m	AREA rad*m	TR m	RESFLD m	RESFRB m
0.0	-0.177	0.000	0.054	1.52	-
1.0	-0.148	-0.003	0.054	1.43	-
3.0	-0.091	-0.007	0.053	1.25	-
5.0	-0.038	-0.009	0.051	1.07	-
9.4	0.000	-0.010	0.069	0.59	-
10.0	0.002	-0.010	0.074	0.53	-
20.0	0.000	-0.010	0.143	-0.71	-
30.0	0.021	-0.008	0.191	-2.00	-
40.0	0.032	-0.004	0.167	-3.33	-
50.0	0.032	0.002	0.117	-4.65	-
60.0	0.030	0.008	0.134	-5.92	-

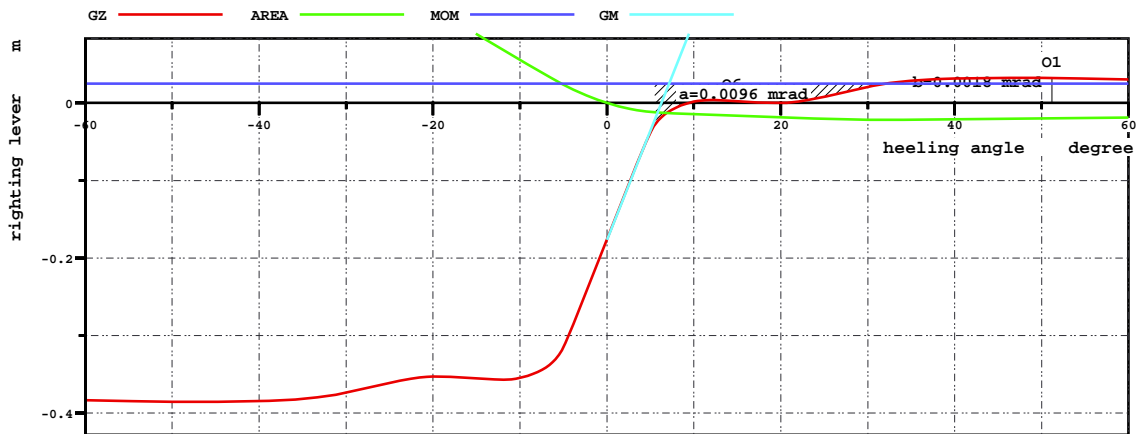

INTACT CRITERIA STATUS

RCR	TEXT	REQ	ATTV	MARGIN	UNIT	STAT
AREA30	GZ Area up to 30 deg.	0.055	0.002	0.053	mrad	NOT .
AREA40	GZ Area up to 40 deg.	0.090	0.006	0.084	mrad	NOT .
AREA3040	Minarea 30-40deg	0.030	0.005	0.025	mrad	NOT .
GZ0.2	Max GZ > 0.2	0.200	0.032	0.168	m	NOT .
MAXGZ25	Max GZ at angle > 25deg	25.000	46.941	21.941	deg	OK
GM0.15	GM > 0.15 m	0.150	1.617	1.467	m	OK
IMOWEATHER	IMO weather crit.	1.000	0.187	0.813		NOT .

1.4 C03 - Lastekondisjon før forlis - BB kregning

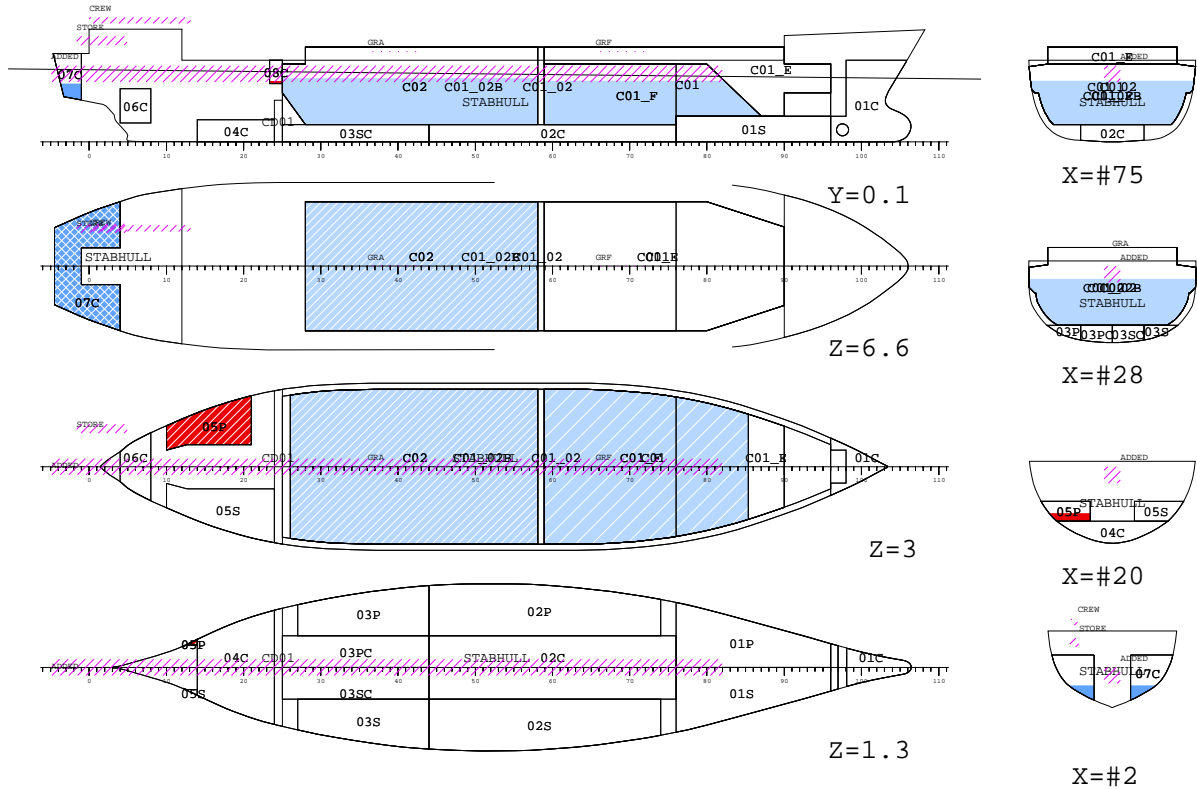

	SEA WATER
	WATER BALLAST
	Solid cargo
	HYDRAULIC OIL
	LUBRICATING OIL
	FRESH WATER
	FUEL OIL

Mean draught (moulded)	5.37 m
Draught AP (moulded)	5.71 m
Draught FP (moulded)	5.03 m
Draught Aft (below keel, x= 0.00 m)	5.72 m
Draught Fore (below keel, x= 64.05 m)	5.04 m
Trim (by stern)	-0.68 m
Heeling to port side	-0.2 deg
KM above the moulded base	5.91 m
KG above the moulded base	3.86 m
GM0 (solid)	2.05 m
Free surface correction	0.03 m
GM (fluid)	2.02 m
Density of water	1.025 t/m ³

	Weight t	LCG m	TCG m	VCG m
Lightweight	831.3	28.14	0.00	5.39
Deadweight	2464.3	31.24	-0.01	3.34
Total weight	3295.6	30.46	-0.01	3.86

DEADWEIGHT COMPONENTS

A) LIQUIDS:

NAME	LOAD	MASS t	FILL %	LCG m	TCG m	VCG m	FRSM tm
Solid cargo	CAS	2353.0	41.7	32.67	0.00	3.26	0.0
FUEL OIL	FO	7.7	3.3	10.73	-2.51	2.36	22.1
FRESH WATER	FW	11.0	10.6	0.26	0.00	4.19	77.5
LUBRICATING OIL	LO	1.6	82.8	14.94	0.00	4.78	0.0
SEA WATER	SW	0.0	0.0	0.00	0.00	0.00	0.0
WATER BALLAST	WB	0.0	0.0	0.00	0.00	0.00	0.0
SUBTOTAL		2373.3	21.3	32.43	-0.01	3.26	99.6

B) LIST OF FIXED MASSES:

NAME	DES	MASS t	LCG m	TCG m	VCG m
FIXED					
CREW	Mannskap og Proviant	2.0	4.00	-3.00	9.60
STORE	Stores	2.0	1.00	-3.00	8.00
ADDED	LETTSKIP ØKNING	87.0	0.00	0.00	5.39
SUBTOTAL		91.0	0.11	-0.13	5.54

RELEVANT OPENINGS

NAME	X m	Y m	Z m	IMMA degree	IMMR m	REDPD m	OTYPE
O1	5.00	-2.500	11.800	-55.4	6.135	0.046	
O2	5.00	2.500	11.800	55.4	6.145	0.045	
O3	16.80	5.100	7.500	19.8	1.971	0.090	
O4	16.80	-5.100	7.500	-19.8	1.948	0.091	
O5	48.00	5.100	7.500	22.7	2.301	0.090	
O6	48.00	-5.100	7.500	-22.7	2.279	0.091	

LIST OF LOADED COMPARTMENTS

NAME	DES	MASS t	FILL %	LCG m	TCG m	VCG m	FRSM tm

CONTENTS=Solid cargo (RHO=1.6)							
C02	Aft Cargohold	1413.0	62.0	25.73	0.00	3.28	0.0
C01_F	Cargo in Fwd Cargohold	940.0	72.1	43.09	0.00	3.22	0.0

SUBTOTAL		2353.0	65.7	32.67	0.00	3.26	0.0
CONTENTS=FUEL OIL (RHO=0.86)							
05P	No.5 PS Bunkers	6.9	32.9	10.23	-2.82	2.07	9.2
08C	Daytank	0.9	9.7	14.75	0.00	4.69	12.9

SUBTOTAL		7.7	26.0	10.73	-2.51	2.36	22.1
CONTENTS=FRESH WATER (RHO=1)							
07C	No.7 Aft C Ballast	11.0	14.1	0.26	0.00	4.19	77.5
CONTENTS=LUBRICATING OIL (RHO=0.92)							
08S	Lub. Oil	0.8	82.8	14.94	3.14	4.78	0.0
08P	Lub. Oil	0.8	82.8	14.94	-3.14	4.78	0.0

SUBTOTAL		1.6	82.8	14.94	0.00	4.78	0.0

Loading condition C03

HEEL degree	GZ m	AREA rad*m	TR m	RESFLD m	RESFRB m
0.0	-0.009	0.000	-0.678	1.97	-
0.2	-0.000	-0.000	-0.678	1.95	-
1.0	0.026	0.000	-0.678	1.88	-
3.0	0.097	0.002	-0.677	1.70	-
5.0	0.168	0.007	-0.675	1.52	-
10.0	0.344	0.029	-0.677	1.06	-
20.0	0.528	0.108	-0.698	-0.02	-
30.0	0.621	0.209	-0.639	-1.21	-
40.0	0.649	0.321	-0.668	-2.48	-
50.0	0.609	0.432	-0.746	-3.76	-
60.0	0.511	0.530	-0.830	-4.98	-

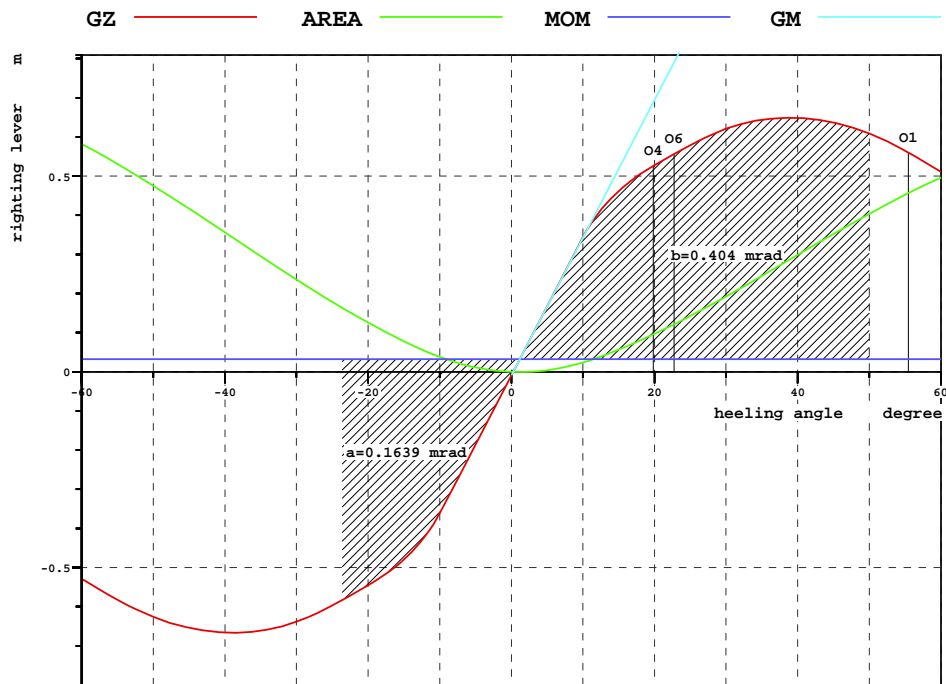

INTACT CRITERIA STATUS

RCR	TEXT	REQ	ATTV	MARGIN	UNIT	STAT
AREA30	GZ Area up to 30 deg.	0.055	0.209	0.154	mrad	OK
AREA40	GZ Area up to 40 deg.	0.090	0.321	0.231	mrad	OK
AREA3040	Minarea 30-40deg	0.030	0.112	0.082	mrad	OK
GZ0.2	Max GZ > 0.2	0.200	0.649	0.449	m	OK
MAXGZ25	Max GZ at angle > 25deg	25.000	38.780	13.780	deg	OK
GM0.15	GM > 0.15 m	0.150	2.016	1.866	m	OK
IMOWEATHER	IMO weather crit.	1.000	2.465	1.465		OK

LONGITUDINAL STRENGTH SUMMARY

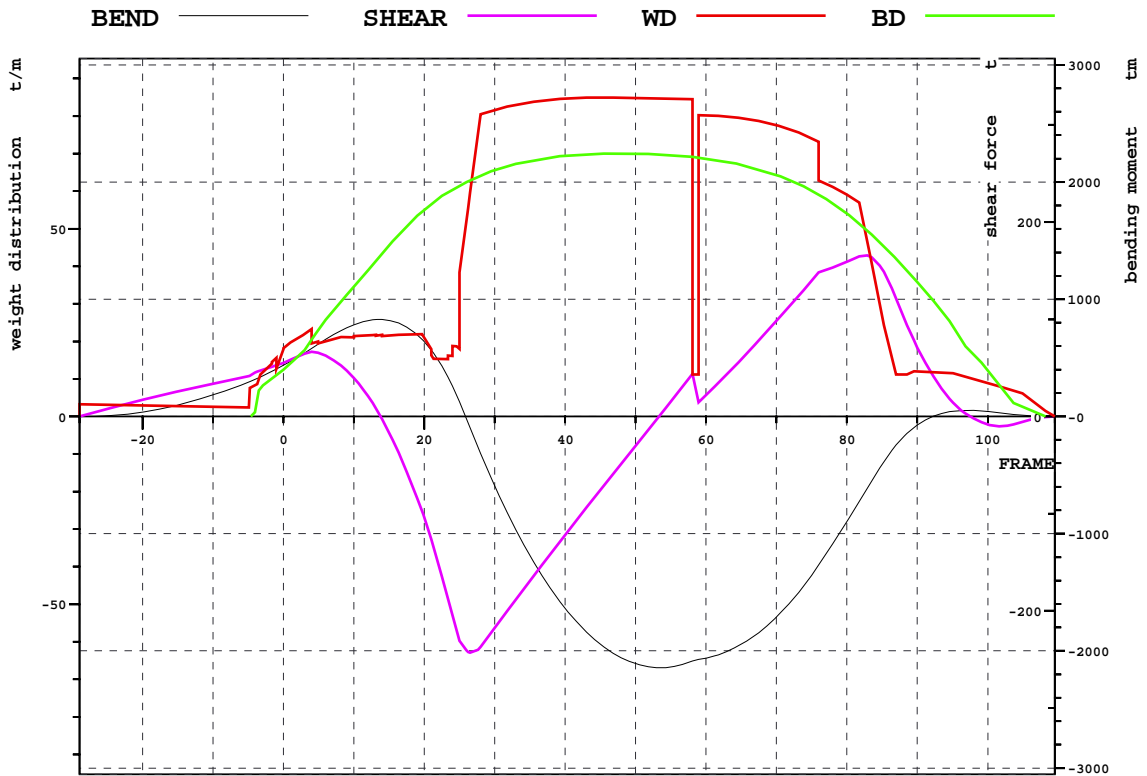





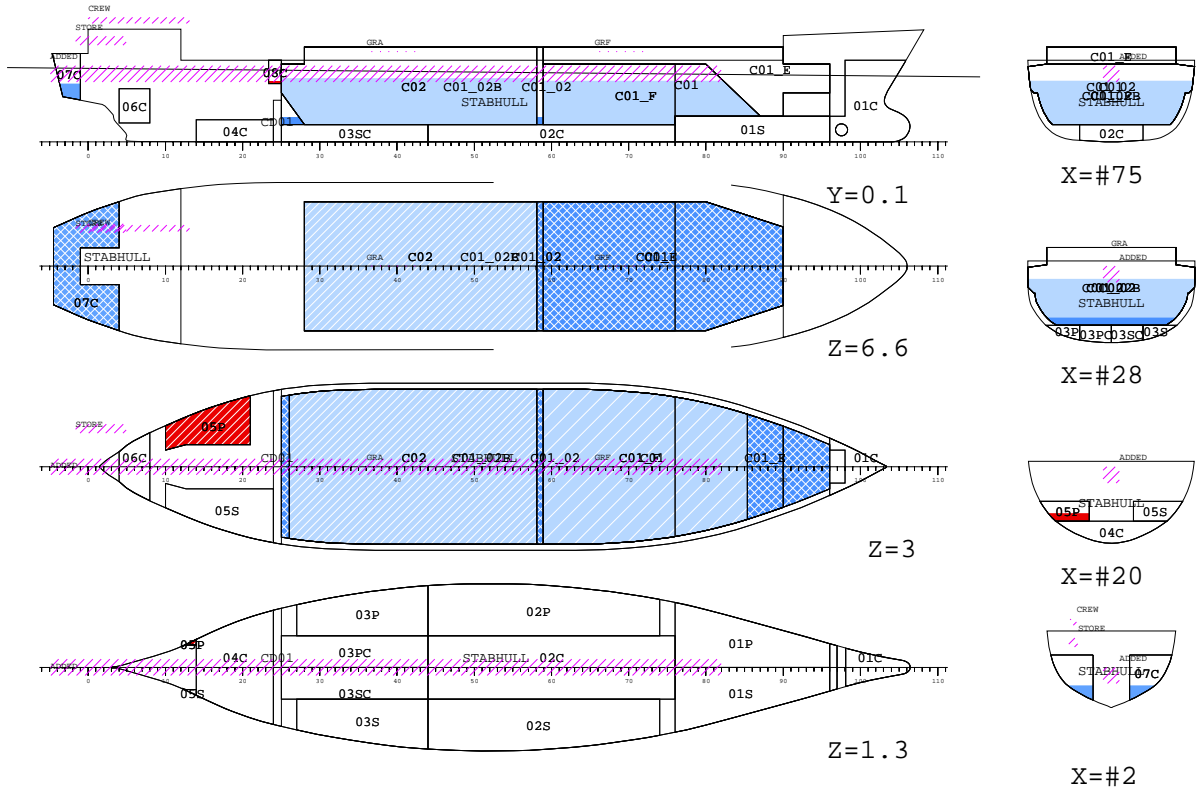

LOADING CONDITION C03, Lastekondisjon før forlis - BB krenning

			X	Frame
Shear force (min)	-243.1 t	Position:	16.2 m	27
Shear force (max)	165.7 t		50.6 m	83
Sagging moment	-2143.9 tm		33.0 m	54
Hogging moment	827.2 tm		8.1 m	13

1.5 C04 - 100 t sjøvann i rommene



	SEA WATER
	WATER BALLAST
	Solid cargo
	HYDRAULIC OIL
	LUBRICATING OIL
	FRESH WATER
	FUEL OIL

Mean draught (moulded)	5.50 m
Draught AP (moulded)	5.81 m
Draught FP (moulded)	5.19 m
Draught Aft (below keel, x= 0.00 m)	5.82 m
Draught Fore (below keel, x= 64.05 m)	5.20 m
Trim (by stern)	-0.62 m
Heeling to port side	-0.3 deg
KM above the moulded base	5.92 m
KG above the moulded base	3.80 m
GM0 (solid)	2.12 m
Free surface correction	0.59 m
GM (fluid)	1.54 m
Density of water	1.025 t/m ³

	Weight t	LCG m	TCG m	VCG m
Lightweight	831.3	28.14	0.00	5.39
Deadweight	2564.3	31.23	-0.01	3.28
Total weight	3395.6	30.48	-0.01	3.80

DEADWEIGHT COMPONENTS

A) LIQUIDS:

NAME	LOAD	MASS t	FILL %	LCG m	TCG m	VCG m	FRSM tm
Solid cargo	CAS	2353.0	41.7	32.67	0.00	3.26	0.0
FUEL OIL	FO	7.7	3.3	10.73	-2.51	2.36	22.1
FRESH WATER	FW	11.0	10.6	0.26	0.00	4.19	77.5
LUBRICATING OIL	LO	1.6	82.8	14.94	0.00	4.78	0.0
SEA WATER	SW	100.0	3.7	30.99	0.00	1.68	1889.8
WATER BALLAST	WB	0.0	0.0	0.00	0.00	0.00	0.0
SUBTOTAL		2473.3	22.7	32.38	-0.01	3.20	1989.4

B) LIST OF FIXED MASSES:

NAME	DES	MASS t	LCG m	TCG m	VCG m
FIXED					
CREW	Mannskap og Proviant	2.0	4.00	-3.00	9.60
STORE	Stores	2.0	1.00	-3.00	8.00
ADDED	LETTSKIP ØKNING	87.0	0.00	0.00	5.39
SUBTOTAL		91.0	0.11	-0.13	5.54

RELEVANT OPENINGS

NAME	X m	Y m	Z m	IMMA degree	IMMR m	REDPD m	OTYPE
O1	5.00	-2.500	11.800	-53.9	6.022	0.047	
O2	5.00	2.500	11.800	53.9	6.036	0.045	
O3	16.80	5.100	7.500	18.5	1.851	0.090	
O4	16.80	-5.100	7.500	-18.5	1.823	0.091	
O5	48.00	5.100	7.500	21.2	2.155	0.090	
O6	48.00	-5.100	7.500	-21.2	2.127	0.091	

LIST OF LOADED COMPARTMENTS

NAME	DES	MASS t	FILL %	LCG m	TCG m	VCG m	FRSM tm

CONTENTS=Solid cargo (RHO=1.6)							
C02	Aft Cargohold	1413.0	62.0	25.73	0.00	3.28	0.0
C01_F	Cargo in Fwd Cargohold	940.0	72.1	43.09	0.00	3.22	0.0

SUBTOTAL		2353.0	65.7	32.67	0.00	3.26	0.0
CONTENTS=FUEL OIL (RHO=0.86)							
05P	No.5 PS Bunkers	6.9	32.9	10.23	-2.82	2.07	9.2
08C	Daytank	0.9	9.7	14.75	0.00	4.69	12.9

SUBTOTAL		7.7	26.0	10.73	-2.51	2.36	22.1
CONTENTS=FRESH WATER (RHO=1)							
07C	No.7 Aft C Ballast	11.0	14.1	0.26	0.00	4.19	77.5
CONTENTS=LUBRICATING OIL (RHO=0.92)							
08S	Lub. Oil	0.8	82.8	14.94	3.14	4.78	0.0
08P	Lub. Oil	0.8	82.8	14.94	-3.14	4.78	0.0

SUBTOTAL		1.6	82.8	14.94	0.00	4.78	0.0
CONTENTS=SEA WATER (RHO=1.025)							
C01_02	Seawater in both cargo h.	100.0	7.8	30.99	0.00	1.68	1889.8

Loading condition C04

HEEL degree	GZ m	AREA rad*m	TR m	RESFLD m	RESFRB m
0.0	-0.009	0.000	-0.624	1.85	-
0.3	0.000	-0.000	-0.624	1.82	-
1.0	0.018	0.000	-0.624	1.76	-
3.0	0.071	0.002	-0.623	1.58	-
5.0	0.125	0.005	-0.621	1.40	-
10.0	0.261	0.022	-0.641	0.94	-
20.0	0.401	0.082	-0.655	-0.18	-
30.0	0.486	0.160	-0.614	-1.39	-
40.0	0.511	0.248	-0.669	-2.68	-
50.0	0.481	0.335	-0.765	-3.99	-
60.0	0.406	0.413	-0.868	-5.22	-

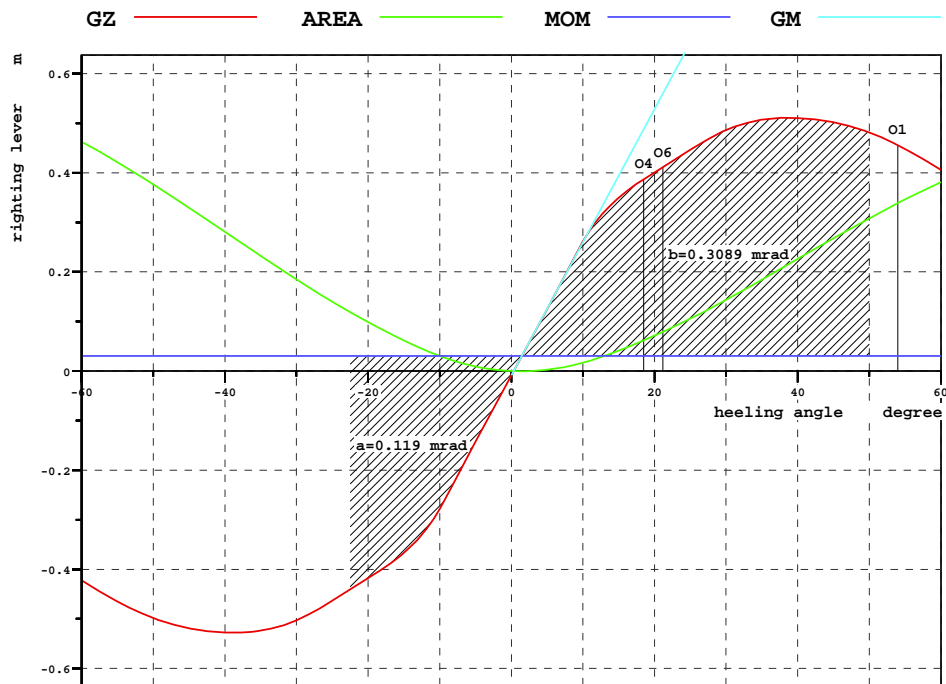

INTACT CRITERIA STATUS

RCR	TEXT	REQ	ATTV	MARGIN	UNIT	STAT
AREA30	GZ Area up to 30 deg.	0.055	0.160	0.105	mrad	OK
AREA40	GZ Area up to 40 deg.	0.090	0.248	0.158	mrad	OK
AREA3040	Minarea 30-40deg	0.030	0.088	0.058	mrad	OK
GZ0.2	Max GZ > 0.2	0.200	0.511	0.311	m	OK
MAXGZ25	Max GZ at angle > 25deg	25.000	38.771	13.771	deg	OK
GM0.15	GM > 0.15 m	0.150	1.537	1.387	m	OK
IMOWEATHER	IMO weather crit.	1.000	2.595	1.595		OK

LONGITUDINAL STRENGTH SUMMARY

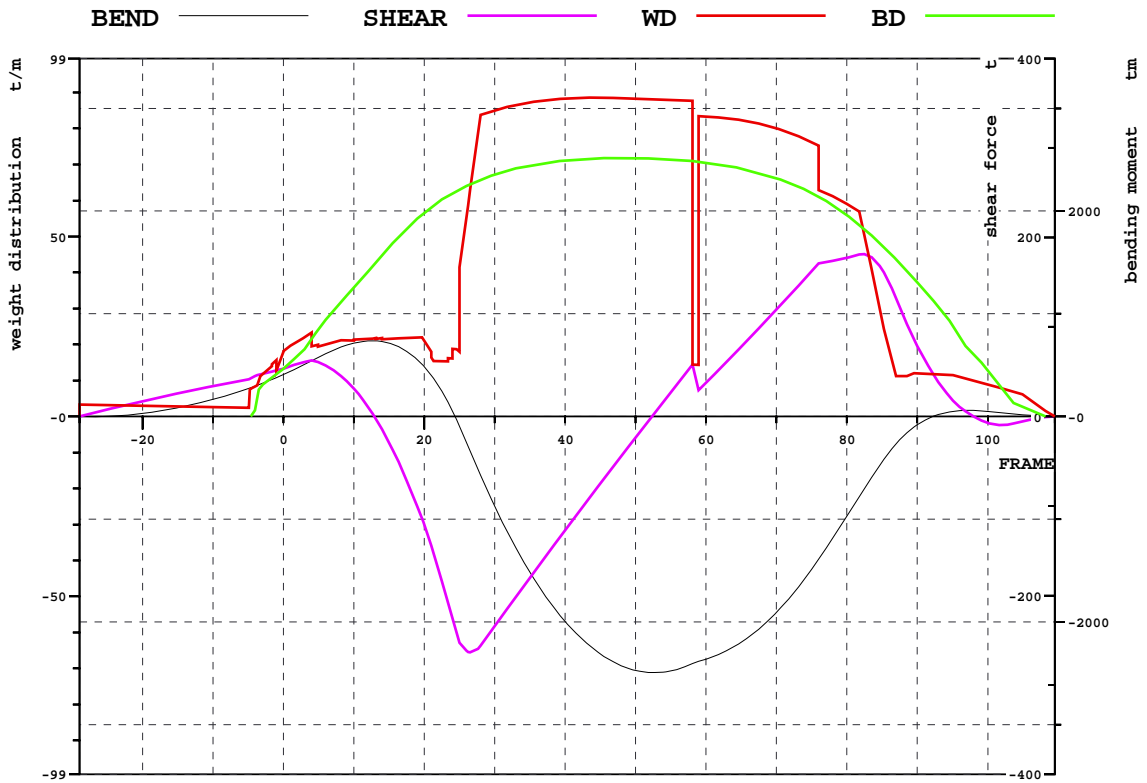





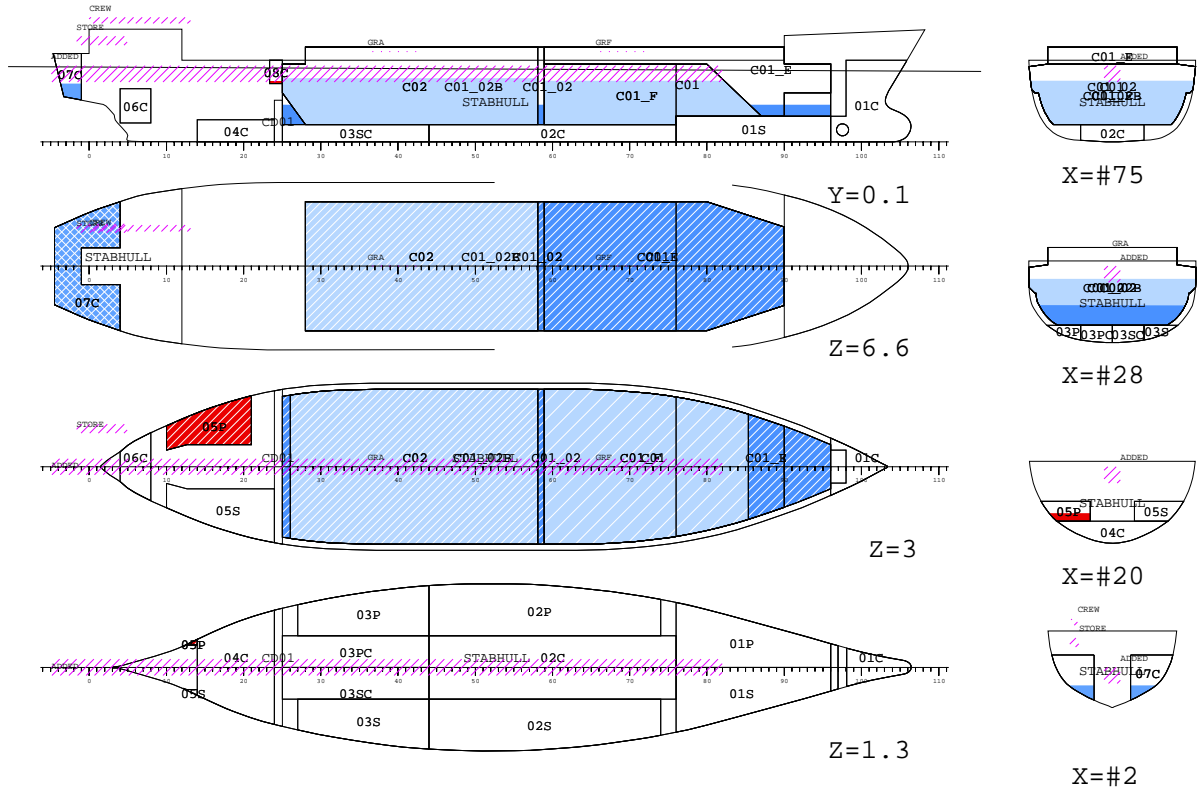

LOADING CONDITION C04, 100 t sjøvann i rommene

		Position:	X	Frame
Shear force (min)	-263.5 t		16.2 m	27
Shear force (max)	181.3 t		50.3 m	83
Sagging moment	-2494.4 tm		32.2 m	53
Hogging moment	737.5 tm		7.7 m	13

1.6 C05 - 300 t sjøvann i rommene



	SEA WATER
	WATER BALLAST
	Solid cargo
	HYDRAULIC OIL
	LUBRICATING OIL
	FRESH WATER
	FUEL OIL

Mean draught (moulded)	5.77 m
Draught AP (moulded)	5.93 m
Draught FP (moulded)	5.62 m
Draught Aft (below keel, x= 0.00 m)	5.94 m
Draught Fore (below keel, x= 64.05 m)	5.63 m
Trim (by stern)	-0.31 m
Heeling to port side	-0.3 deg
KM above the moulded base	5.95 m
KG above the moulded base	3.72 m
GM0 (solid)	2.23 m
Free surface correction	0.68 m
GM (fluid)	1.55 m
Density of water	1.025 t/m ³

	Weight t	LCG m	TCG m	VCG m
Lightweight	831.3	28.14	0.00	5.39
Deadweight	2764.3	31.48	-0.01	3.22
Total weight	3595.6	30.71	-0.01	3.72

DEADWEIGHT COMPONENTS

A) LIQUIDS:

NAME	LOAD	MASS t	FILL %	LCG m	TCG m	VCG m	FRSM tm
Solid cargo	CAS	2353.0	41.7	32.67	0.00	3.26	0.0
FUEL OIL	FO	7.7	3.3	10.73	-2.51	2.36	22.1
FRESH WATER	FW	11.0	10.6	0.26	0.00	4.19	77.5
LUBRICATING OIL	LO	1.6	82.8	14.94	0.00	4.78	0.0
SEA WATER	SW	300.0	11.1	33.46	0.00	2.21	2358.7
WATER BALLAST	WB	0.0	0.0	0.00	0.00	0.00	0.0
SUBTOTAL		2673.3	25.5	32.55	-0.01	3.14	2458.3

B) LIST OF FIXED MASSES:

NAME	DES	MASS t	LCG m	TCG m	VCG m
FIXED					
CREW	Mannskap og Proviant	2.0	4.00	-3.00	9.60
STORE	Stores	2.0	1.00	-3.00	8.00
ADDED	LETTSKIP ØKNING	87.0	0.00	0.00	5.39
SUBTOTAL		91.0	0.11	-0.13	5.54

RELEVANT OPENINGS

NAME	X m	Y m	Z m	IMMA degree	IMMR m	REDPD m	OTYPE
O1	5.00	-2.500	11.800	-51.9	5.883	0.046	
O2	5.00	2.500	11.800	51.9	5.896	0.045	
O3	16.80	5.100	7.500	16.1	1.654	0.090	
O4	16.80	-5.100	7.500	-16.1	1.627	0.091	
O5	48.00	5.100	7.500	17.5	1.806	0.090	
O6	48.00	-5.100	7.500	-17.5	1.780	0.091	

LIST OF LOADED COMPARTMENTS

NAME	DES	MASS t	FILL %	LCG m	TCG m	VCG m	FRSM tm

CONTENTS=Solid cargo (RHO=1.6)							
C02	Aft Cargohold	1413.0	62.0	25.73	0.00	3.28	0.0
C01_F	Cargo in Fwd Cargohold	940.0	72.1	43.09	0.00	3.22	0.0

SUBTOTAL		2353.0	65.7	32.67	0.00	3.26	0.0
CONTENTS=FUEL OIL (RHO=0.86)							
05P	No.5 PS Bunkers	6.9	32.9	10.23	-2.82	2.07	9.2
08C	Daytank	0.9	9.7	14.75	0.00	4.69	12.9

SUBTOTAL		7.7	26.0	10.73	-2.51	2.36	22.1
CONTENTS=FRESH WATER (RHO=1)							
07C	No.7 Aft C Ballast	11.0	14.1	0.26	0.00	4.19	77.5
CONTENTS=LUBRICATING OIL (RHO=0.92)							
08S	Lub. Oil	0.8	82.8	14.94	3.14	4.78	0.0
08P	Lub. Oil	0.8	82.8	14.94	-3.14	4.78	0.0

SUBTOTAL		1.6	82.8	14.94	0.00	4.78	0.0
CONTENTS=SEA WATER (RHO=1.025)							
C01_02	Seawater in both cargo h.	300.0	23.3	33.46	0.00	2.21	2358.7

Loading condition C05

HEEL degree	GZ m	AREA rad*m	TR m	RESFLD m	RESFRB m
0.0	-0.008	0.000	-0.313	1.65	-
0.3	-0.000	-0.000	-0.313	1.63	-
1.0	0.019	0.000	-0.314	1.56	-
3.0	0.073	0.002	-0.314	1.39	-
5.0	0.128	0.005	-0.315	1.21	-
10.0	0.213	0.021	-0.345	0.71	-
20.0	0.233	0.060	-0.312	-0.46	-
30.0	0.266	0.104	-0.293	-1.71	-
40.0	0.274	0.151	-0.358	-3.04	-
50.0	0.258	0.198	-0.448	-4.37	-
60.0	0.215	0.239	-0.532	-5.63	-

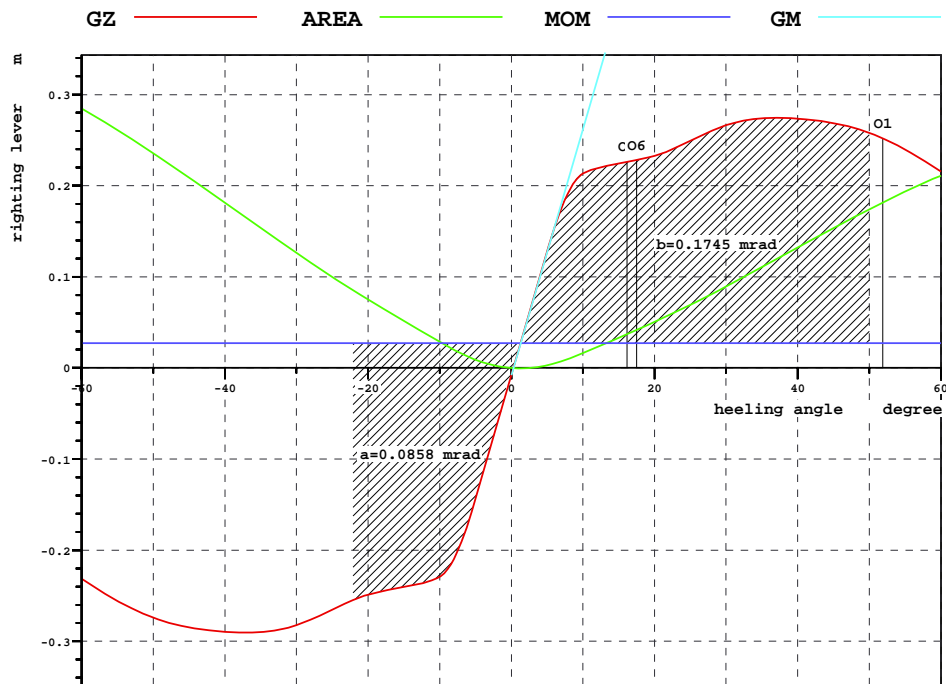

INTACT CRITERIA STATUS

RCR	TEXT	REQ	ATTV	MARGIN	UNIT	STAT
AREA30	GZ Area up to 30 deg.	0.055	0.104	0.049	mrad	OK
AREA40	GZ Area up to 40 deg.	0.090	0.151	0.061	mrad	OK
AREA3040	Minarea 30-40deg	0.030	0.048	0.018	mrad	OK
GZ0.2	Max GZ > 0.2	0.200	0.275	0.075	m	OK
MAXGZ25	Max GZ at angle > 25deg	25.000	37.025	12.025	deg	OK
GM0.15	GM > 0.15 m	0.150	1.548	1.398	m	OK
IMOWEATHER	IMO weather crit.	1.000	2.035	1.035		OK

LONGITUDINAL STRENGTH SUMMARY

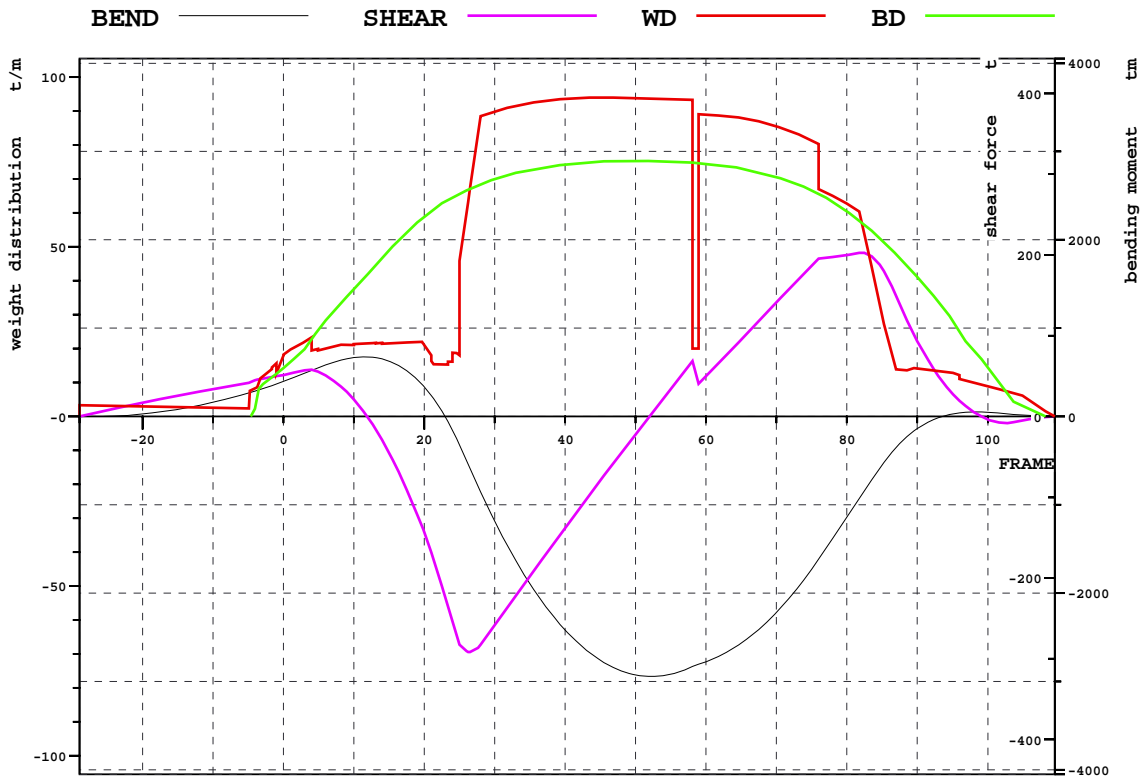

LOADING CONDITION C05, 300 t sjøvann i rommene

		Position:	X	Frame
Shear force (min)	-291.7 t		16.2 m	27
Shear force (max)	202.6 t		49.9 m	82
Sagging moment	-2944.0 tm		32.2 m	53
Hogging moment	674.7 tm		6.9 m	11

1.7 C06 - 750 t sjøvann i rommene

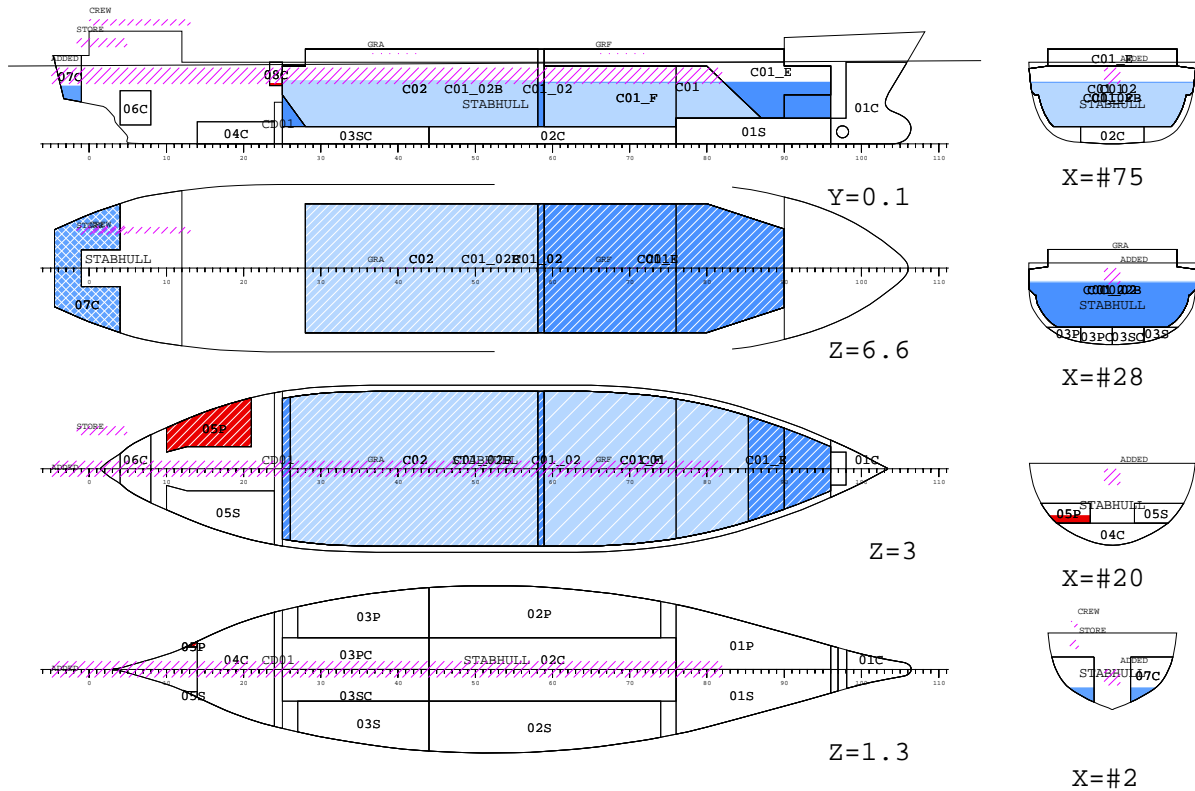

■	SEA WATER
■	WATER BALLAST
■	Solid cargo
■	HYDRAULIC OIL
■	LUBRICATING OIL
■	FRESH WATER
■	FUEL OIL

Mean draught (moulded)	6.37 m
Draught AP (moulded)	6.18 m
Draught FP (moulded)	6.55 m
Draught Aft (below keel, x= 0.00 m)	6.19 m
Draught Fore (below keel, x= 64.05 m)	6.56 m
Trim (by head)	0.36 m
Heeling to port side	-0.3 deg
KM above the moulded base	5.84 m
KG above the moulded base	3.75 m
GM0 (solid)	2.10 m
Free surface correction	0.84 m
GM (fluid)	1.26 m
Density of water	1.025 t/m ³

	Weight t	LCG m	TCG m	VCG m
Lightweight	831.3	28.14	0.00	5.39
Deadweight	3214.3	32.01	-0.01	3.32
Total weight	4045.6	31.22	-0.01	3.75

DEADWEIGHT COMPONENTS
A) LIQUIDS:

NAME	LOAD	MASS t	FILL %	LCG m	TCG m	VCG m	FRSM tm
Solid cargo	CAS	2353.0	41.7	32.67	0.00	3.26	0.0
FUEL OIL	FO	7.7	3.3	10.73	-2.51	2.36	22.1
FRESH WATER	FW	11.0	10.6	0.26	0.00	4.19	77.5
LUBRICATING OIL	LO	1.6	82.8	14.94	0.00	4.78	0.0
SEA WATER	SW	750.0	27.9	34.55	0.00	3.25	3279.9
WATER BALLAST	WB	0.0	0.0	0.00	0.00	0.00	0.0
SUBTOTAL		3123.3	31.7	32.94	-0.01	3.26	3379.5

B) LIST OF FIXED MASSES:

NAME	DES	MASS t	LCG m	TCG m	VCG m
FIXED					
CREW	Mannskap og Proviant	2.0	4.00	-3.00	9.60
STORE	Stores	2.0	1.00	-3.00	8.00
ADDED	LETTSKIP ØKNING	87.0	0.00	0.00	5.39
SUBTOTAL		91.0	0.11	-0.13	5.54

RELEVANT OPENINGS

NAME	X m	Y m	Z m	IMMA degree	IMMR m	REDPD m	OTYPE
O1	5.00	-2.500	11.800	-47.5	5.573	0.047	
O2	5.00	2.500	11.800	47.5	5.587	0.045	
O3	16.80	5.100	7.500	10.4	1.221	0.090	
O4	16.80	-5.100	7.500	-10.4	1.192	0.091	
O5	48.00	5.100	7.500	8.3	1.045	0.090	
O6	48.00	-5.100	7.500	-8.3	1.015	0.091	

LIST OF LOADED COMPARTMENTS

NAME	DES	MASS t	FILL %	LCG m	TCG m	VCG m	FRSM tm

CONTENTS=Solid cargo (RHO=1.6)							
C02	Aft Cargohold	1413.0	62.0	25.73	0.00	3.28	0.0
C01_F	Cargo in Fwd Cargohold	940.0	72.1	43.09	0.00	3.22	0.0

SUBTOTAL		2353.0	65.7	32.67	0.00	3.26	0.0
CONTENTS=FUEL OIL (RHO=0.86)							
05P	No.5 PS Bunkers	6.9	32.9	10.23	-2.82	2.07	9.2
08C	Daytank	0.9	9.7	14.75	0.00	4.69	12.9

SUBTOTAL		7.7	26.0	10.73	-2.51	2.36	22.1
CONTENTS=FRESH WATER (RHO=1)							
07C	No.7 Aft C Ballast	11.0	14.1	0.26	0.00	4.19	77.5
CONTENTS=LUBRICATING OIL (RHO=0.92)							
08S	Lub. Oil	0.8	82.8	14.94	3.14	4.78	0.0
08P	Lub. Oil	0.8	82.8	14.94	-3.14	4.78	0.0

SUBTOTAL		1.6	82.8	14.94	0.00	4.78	0.0
CONTENTS=SEA WATER (RHO=1.025)							
C01_02	Seawater in both cargo h.	750.0	58.2	34.55	0.00	3.25	3279.9

Loading condition C06

HEEL degree	GZ m	AREA rad*m	TR m	RESFLD m	RESFRB m
0.0	-0.007	0.000	0.361	1.04	-
0.3	-0.000	-0.000	0.362	1.02	-
1.0	0.012	0.000	0.383	0.94	-
3.0	0.024	0.001	0.455	0.70	-
5.0	0.021	0.002	0.496	0.44	-
10.0	0.013	0.003	0.563	-0.22	-
20.0	0.032	0.007	0.630	-1.53	-
30.0	0.004	0.011	0.713	-2.91	-
40.0	-0.036	0.008	0.768	-4.33	-
50.0	-0.058	-0.001	0.866	-5.74	-
60.0	-0.069	-0.012	0.982	-7.07	-

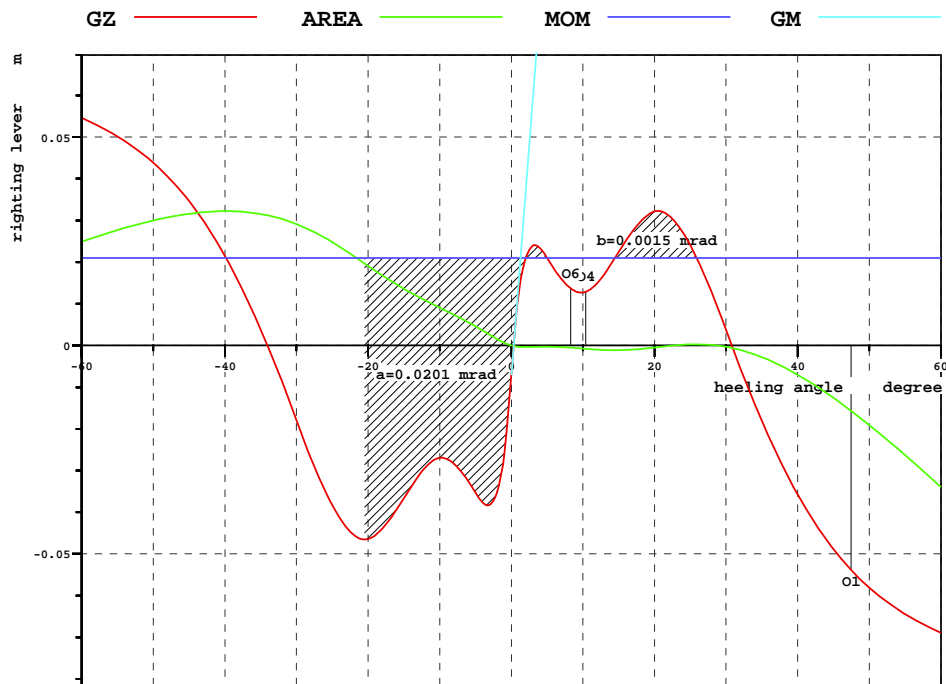

INTACT CRITERIA STATUS

RCR	TEXT	REQ	ATTV	MARGIN	UNIT	STAT
AREA30	GZ Area up to 30 deg.	0.055	0.011	0.044	mrad	NOT .
AREA40	GZ Area up to 40 deg.	0.090	0.011	0.079	mrad	NOT .
AREA3040	Minarea 30-40deg	0.030	0.000	0.030	mrad	NOT .
GZ0.2	Max GZ > 0.2	0.200	0.004	0.196	m	NOT .
MAXGZ25	Max GZ at angle > 25deg	25.000	20.487	4.513	deg	NOT .
GM0.15	GM > 0.15 m	0.150	1.261	1.111	m	OK
IMOWEATHER	IMO weather crit.	1.000	0.076	0.924		NOT .

LONGITUDINAL STRENGTH SUMMARY

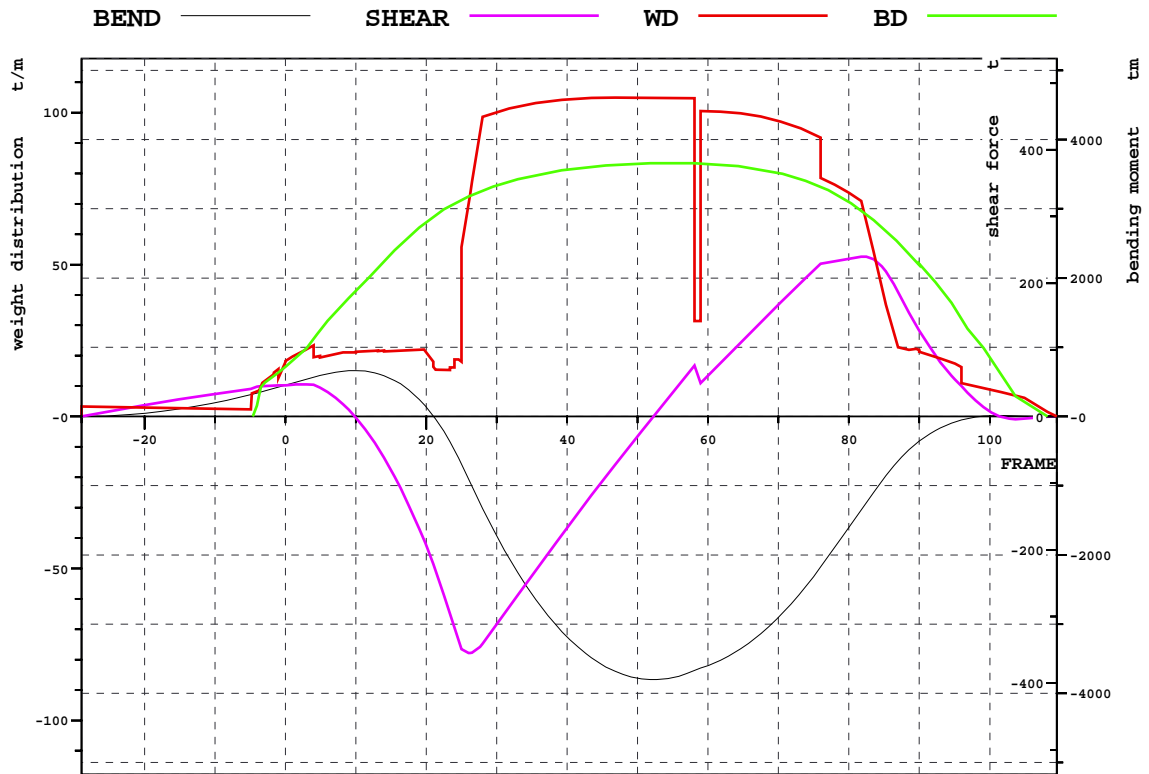





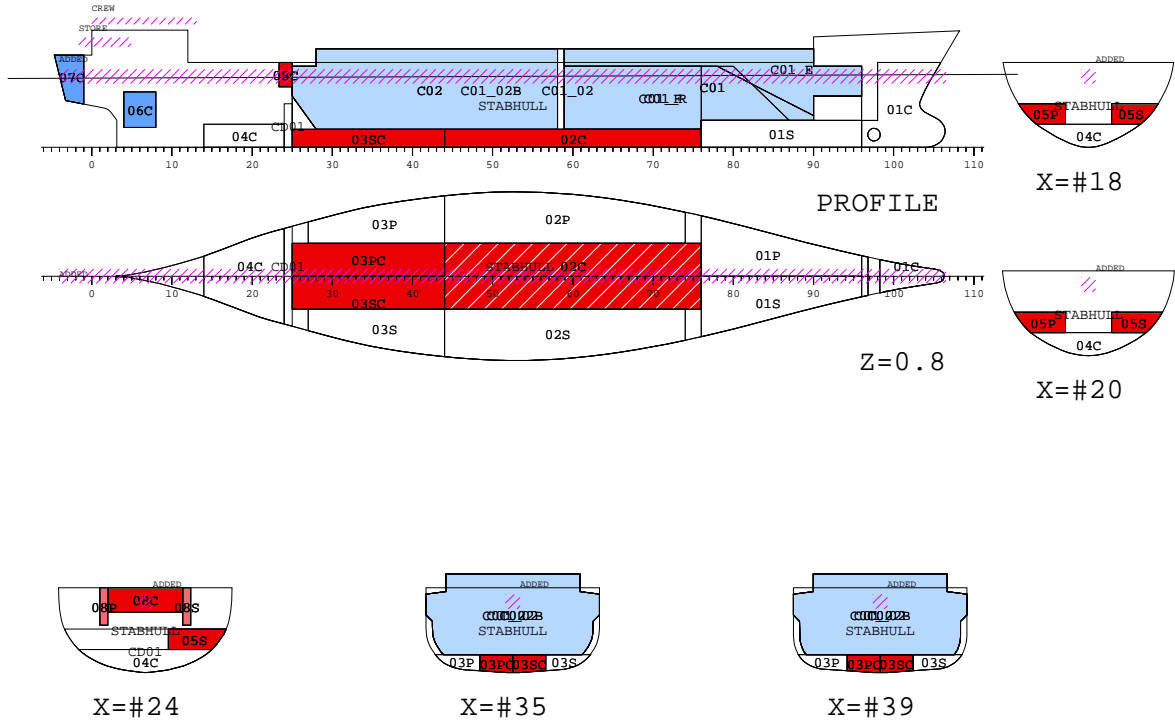

LOADING CONDITION C06, 750 t sjøvann i rommene

		Position:	X	Frame
Shear force (min)	-354.7 t		16.0 m	26
Shear force (max)	239.8 t		50.3 m	83
Sagging moment	-3802.3 tm		32.2 m	53
Hogging moment	664.1 tm		6.1 m	10

1.2 HL1 - Homogent lastet til 5.40 m - 100% Fo & Fv



	SEA WATER
	WATER BALLAST
	Solid cargo
	HYDRAULIC OIL
	LUBRICATING OIL
	FRESH WATER
	FUEL OIL

Mean draught (moulded)	5.40 m
Draught AP (moulded)	5.27 m
Draught FP (moulded)	5.53 m
Draught Aft (below keel, x= 0.00 m)	5.28 m
Draught Fore (below keel, x= 64.05 m)	5.54 m
Trim (by head)	0.26 m
Heeling to starboard side	0.4 deg
KM above the moulded base	5.90 m
KG above the moulded base	4.53 m
GM0 (solid)	1.36 m
Free surface correction	0.19 m
GM (fluid)	1.18 m
Density of water	1.025 t/m ³

	Weight	LCG	TCG	VCG
	t	m	m	m
Lightweight	831.3	28.37	0.00	5.39
Deadweight	2458.9	32.46	0.01	4.24
Total weight	3290.2	31.42	0.01	4.53

DEADWEIGHT COMPONENTS
A) LIQUIDS:

NAME	LOAD	MASS t	FILL %	LCG m	TCG m	VCG m	FRSM tm
Solid cargo	CAS	2045.0	62.2	34.97	0.00	4.47	0.0
FUEL OIL	FO	224.8	96.6	25.80	0.13	1.28	256.2
FRESH WATER	FW	100.2	97.0	0.93	0.00	5.05	362.8
LUBRICATING OIL	LO	1.8	95.0	14.95	0.00	4.95	0.0
SEA WATER	SW	0.0	0.0	0.00	0.00	0.00	0.0
WATER BALLAST	WB	0.0	0.0	0.00	0.00	0.00	0.0
SUBTOTAL		2371.9	44.4	32.65	0.01	4.20	619.0

B) LIST OF FIXED MASSES:

NAME	DES	MASS t	LCG m	TCG m	VCG m
FIXED					
CREW	Mannskap og Proviant	2.0	4.00	0.00	9.60
STORE	Stores	2.0	1.00	0.00	8.00
ADDED	LETTSKIP ØKNING	83.0	28.37	0.00	5.39
SUBTOTAL		87.0	27.18	0.00	5.55

RELEVANT OPENINGS

NAME	X m	Y m	Z m	IMMA degree	IMMR m	REDPD m	OTYPE
O1	5.00	-2.500	11.800	-59.3	6.511	0.045	
O2	5.00	2.500	11.800	59.3	6.493	0.047	
O3	16.80	5.100	7.500	21.7	2.125	0.091	
O4	16.80	-5.100	7.500	-21.7	2.163	0.090	
O5	48.00	5.100	7.500	20.2	1.997	0.091	
O6	48.00	-5.100	7.500	-20.2	2.035	0.090	

LIST OF LOADED COMPARTMENTS

NAME	DES	MASS t	FILL %	LCG m	TCG m	VCG m	FRSM tm

CONTENTS=Solid cargo (RHO=0.755)							
C01	Fwd Cargohold	969.0	100.0	45.22	0.00	4.58	0.0
C02	Aft Cargohold	1076.0	100.0	25.75	0.00	4.38	0.0

SUBTOTAL		2045.0	100.0	34.97	0.00	4.47	0.0
CONTENTS=FUEL OIL (RHO=0.86)							
02C	No.2 C Bunkers	104.5	96.0	36.60	0.00	0.68	172.2
03PC	No.3 PS-C Bunkers	31.5	98.0	21.08	-1.22	0.70	12.8
03SC	No.3 SB-C Bunkers	31.5	98.0	21.08	1.22	0.70	12.8
05P	No.5 PS Bunkers	20.5	98.0	10.04	-3.04	2.59	17.4
05S	No.5 SB Bunkers	28.4	95.0	11.16	3.21	2.56	28.1
08C	Daytank	8.5	95.0	14.75	0.00	5.48	12.9

SUBTOTAL		224.8	96.6	25.80	0.13	1.28	256.2
CONTENTS=FRESH WATER (RHO=1)							
06C	No.6 Aftpeak C FW	24.6	97.0	3.79	0.00	3.25	94.5
07C	No.7 Aft C Ballast	75.6	97.0	0.00	0.00	5.64	268.3

SUBTOTAL		100.2	97.0	0.93	0.00	5.05	362.8
CONTENTS=LUBRICATING OIL (RHO=0.92)							
08S	Lub. Oil	0.9	95.0	14.95	3.15	4.95	0.0
08P	Lub. Oil	0.9	95.0	14.95	-3.15	4.95	0.0

SUBTOTAL		1.8	95.0	14.95	0.00	4.95	0.0

Loading condition HL1

HEEL degree	GZ m	AREA rad*m	TR m	RESFLD m	RESFRB m
0.0	-0.009	0.000	0.262	2.04	-
0.4	0.000	0.000	0.262	2.00	-
1.0	0.012	0.000	0.263	1.95	-
3.0	0.057	0.001	0.263	1.77	-
5.0	0.105	0.004	0.263	1.59	-
10.0	0.227	0.019	0.265	1.13	-
20.0	0.293	0.067	0.352	0.03	-
30.0	0.283	0.117	0.467	-1.20	-
40.0	0.223	0.162	0.583	-2.48	-
50.0	0.103	0.192	0.645	-3.76	-
60.0	-0.060	0.196	0.672	-4.95	-

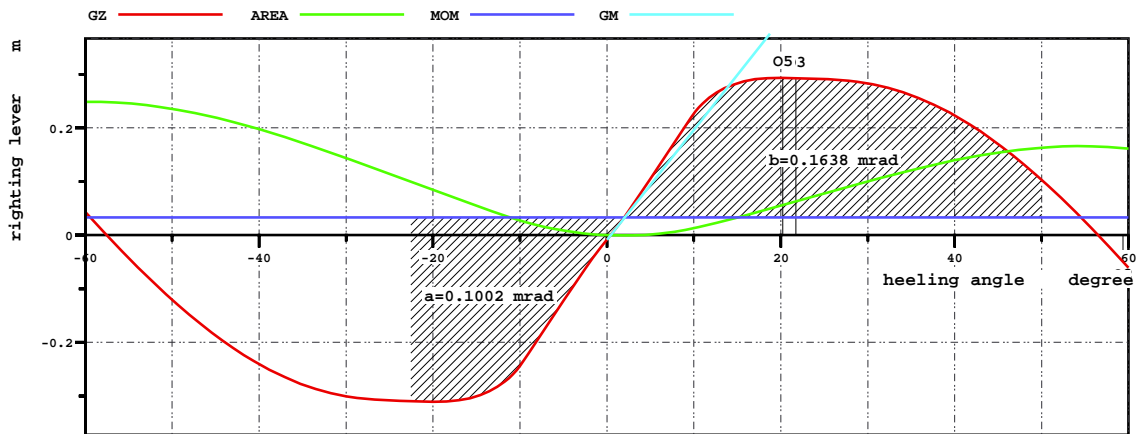

INTACT CRITERIA STATUS

RCR	TEXT	REQ	ATTV	MARGIN	UNIT	STAT
AREA30	GZ Area up to 30 deg.	0.055	0.117	0.062	mrad	OK
AREA40	GZ Area up to 40 deg.	0.090	0.163	0.073	mrad	OK
AREA3040	Minarea 30-40deg	0.030	0.045	0.015	mrad	OK
GZ0.2	Max GZ > 0.2	0.200	0.283	0.083	m	OK
MAXGZ25	Max GZ at angle > 25deg	25.000	19.478	5.522	deg	NOT .
GM0.15	GM > 0.15 m	0.150	1.176	1.026	m	OK
IMOWEATHER	IMO weather crit.	1.000	1.636	0.636		OK

1.3 HL2 - Homogent lastet (5.40 m) - 10% Fo & Fv

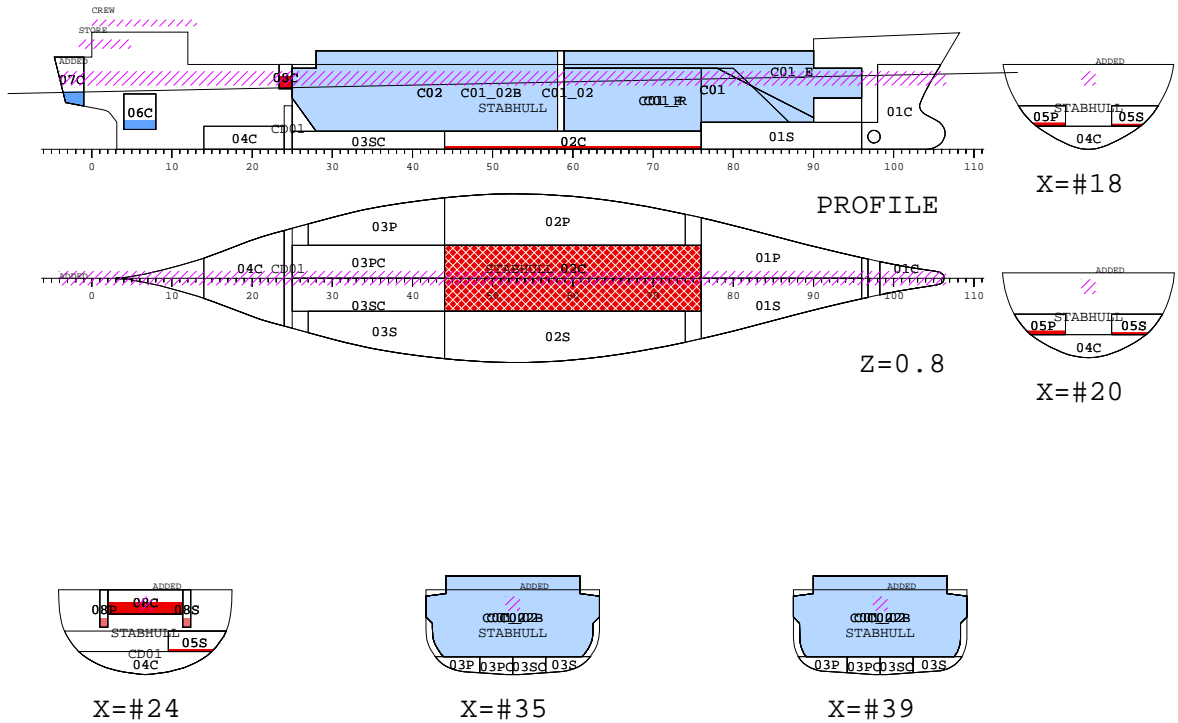

SEA WATER	Mean draught (moulded)	5.04 m
WATER BALLAST	Draught AP (moulded)	4.36 m
Solid cargo	Draught FP (moulded)	5.71 m
HYDRAULIC OIL	Draught Aft (below keel, x= 0.00 m)	4.37 m
LUBRICATING OIL	Draught Fore (below keel, x= 64.05 m)	5.72 m
FRESH WATER	Trim (by head)	1.35 m
FUEL OIL	Heeling	0.0 deg
	KM above the moulded base	5.86 m
	KG above the moulded base	4.73 m
	GM0 (solid)	1.13 m
	Free surface correction	0.09 m
	GM (fluid)	1.04 m
	Density of water	1.025 t/m3

	Weight t	LCG m	TCG m	VCG m
Lightweight	831.3	28.37	0.00	5.39
Deadweight	2159.1	34.42	0.00	4.48
Total weight	2990.4	32.74	0.00	4.73

DEADWEIGHT COMPONENTS
A) LIQUIDS:

NAME	LOAD	MASS t	FILL %	LCG m	TCG m	VCG m	FRSM tm
Solid cargo	CAS	2037.9	62.2	35.01	0.00	4.47	0.0
FUEL OIL	FO	23.4	10.1	25.69	0.00	1.51	203.1
FRESH WATER	FW	10.3	10.0	1.18	0.00	3.53	61.4
LUBRICATING OIL	LO	0.5	25.0	14.94	0.00	3.96	0.0
SEA WATER	SW	0.0	0.0	0.00	0.00	0.00	0.0
WATER BALLAST	WB	0.0	0.0	0.00	0.00	0.00	0.0
SUBTOTAL		2072.1	39.7	34.73	0.00	4.44	264.5

B) LIST OF FIXED MASSES:

NAME	DES	MASS t	LCG m	TCG m	VCG m
FIXED					
CREW	Mannskap og Proviant	2.0	4.00	0.00	9.60
STORE	Stores	2.0	1.00	0.00	8.00
ADDED	LETTSKIP ØKNING	83.0	28.37	0.00	5.39
SUBTOTAL		87.0	27.18	0.00	5.55

RELEVANT OPENINGS

NAME	X m	Y m	Z m	IMMA degree	IMMR m	REDPD m	OTYPE
O1	5.00	-2.500	11.800	-68.6	7.329	0.045	
O2	5.00	2.500	11.800	68.6	7.329	0.045	
O3	16.80	5.100	7.500	28.2	2.782	0.090	
O4	16.80	-5.100	7.500	-28.2	2.782	0.090	
O5	48.00	5.100	7.500	21.5	2.126	0.090	
O6	48.00	-5.100	7.500	-21.5	2.126	0.090	

LIST OF LOADED COMPARTMENTS

NAME	DES	MASS t	FILL %	LCG m	TCG m	VCG m	FRSM tm

CONTENTS=Solid cargo (RHO=0.755)							
C01	Fwd Cargohold	969.0	100.0	45.22	0.00	4.58	0.0
C02	Aft Cargohold	1068.9	100.0	25.75	0.00	4.38	0.0

SUBTOTAL		2037.9	100.0	35.01	0.00	4.47	0.0
CONTENTS=FUEL OIL (RHO=0.86)							
02C	No.2 C Bunkers	12.8	11.8	36.60	0.00	0.12	172.2
05P	No.5 PS Bunkers	3.1	15.0	10.23	-2.71	1.88	6.5
05S	No.5 SB Bunkers	3.0	10.0	11.31	2.88	1.82	11.4
08C	Daytank	4.5	50.0	14.75	0.00	5.06	12.9

SUBTOTAL		23.4	13.9	25.69	0.00	1.51	203.1
CONTENTS=FRESH WATER (RHO=1)							
06C	No.6 Aftpeak C FW	2.5	10.0	3.91	0.00	1.90	2.0
07C	No.7 Aft C Ballast	7.8	10.0	0.29	0.00	4.06	59.4

SUBTOTAL		10.3	10.0	1.18	0.00	3.53	61.4
CONTENTS=LUBRICATING OIL (RHO=0.92)							
08S	Lub. Oil	0.2	25.0	14.94	3.15	3.96	0.0
08P	Lub. Oil	0.2	25.0	14.94	-3.15	3.96	0.0

SUBTOTAL		0.5	25.0	14.94	0.00	3.96	0.0

Loading condition HL2

HEEL degree	GZ m	AREA rad*m	TR m	RESFLD m	RESFRB m
0.0	0.000	0.000	1.348	2.13	-
1.0	0.018	0.000	1.348	2.04	-
3.0	0.055	0.001	1.347	1.86	-
5.0	0.092	0.004	1.346	1.68	-
10.0	0.193	0.016	1.339	1.22	-
20.0	0.307	0.062	1.496	0.18	-
30.0	0.288	0.116	1.654	-1.01	-
40.0	0.217	0.160	1.905	-2.28	-
50.0	0.072	0.187	2.161	-3.55	-
60.0	-0.136	0.182	2.357	-4.73	-

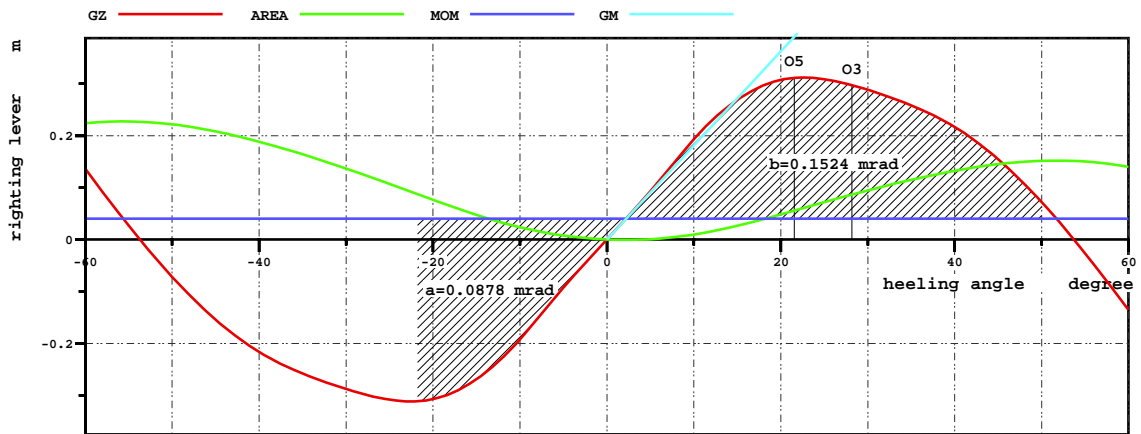





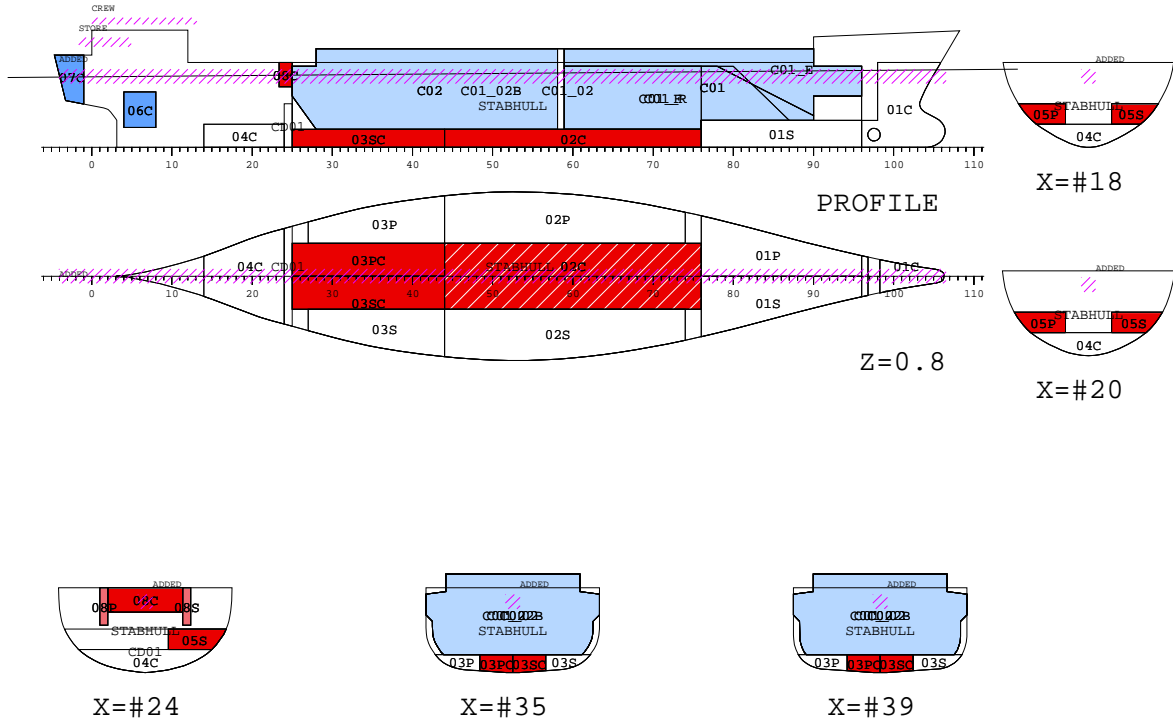

INTACT CRITERIA STATUS

RCR	TEXT	REQ	ATTV	MARGIN	UNIT	STAT
AREA30	GZ Area up to 30 deg.	0.055	0.116	0.061	mrad	OK
AREA40	GZ Area up to 40 deg.	0.090	0.160	0.070	mrad	OK
AREA3040	Minarea 30-40deg	0.030	0.045	0.015	mrad	OK
GZ0.2	Max GZ > 0.2	0.200	0.288	0.088	m	OK
MAXGZ25	Max GZ at angle > 25deg	25.000	22.505	2.495	deg	NOT .
GM0.15	GM > 0.15 m	0.150	1.038	0.888	m	OK
IMOWEATHER	IMO weather crit.	1.000	1.735	0.735		OK

1.4 HL5 - Homogent lastet 5.625 m - 100% Fo & Fv



	SEA WATER
	WATER BALLAST
	Solid cargo
	HYDRAULIC OIL
	LUBRICATING OIL
	FRESH WATER
	FUEL OIL

Mean draught (moulded)	5.63 m
Draught AP (moulded)	5.37 m
Draught FP (moulded)	5.88 m
Draught Aft (below keel, x= 0.00 m)	5.38 m
Draught Fore (below keel, x= 64.05 m)	5.89 m
Trim (by head)	0.52 m
Heeling to starboard side	0.4 deg
KM above the moulded base	5.93 m
KG above the moulded base	4.53 m
GM0 (solid)	1.40 m
Free surface correction	0.18 m
GM (fluid)	1.22 m
Density of water	1.025 t/m ³

	Weight t	LCG m	TCG m	VCG m
Lightweight	831.3	28.37	0.00	5.39
Deadweight	2626.8	32.62	0.01	4.26
Total weight	3458.1	31.60	0.01	4.53

DEADWEIGHT COMPONENTS
A) LIQUIDS:

NAME	LOAD	MASS t	FILL %	LCG m	TCG m	VCG m	FRSM tm
Solid cargo	CAS	2213.0	62.2	34.97	0.00	4.47	0.0
FUEL OIL	FO	224.8	96.6	25.80	0.13	1.28	256.2
FRESH WATER	FW	100.2	97.0	0.93	0.00	5.05	362.8
LUBRICATING OIL	LO	1.8	95.0	14.95	0.00	4.95	0.0
SEA WATER	SW	0.0	0.0	0.00	0.00	0.00	0.0
WATER BALLAST	WB	0.0	0.0	0.00	0.00	0.00	0.0
SUBTOTAL		2539.8	44.4	32.80	0.01	4.21	619.0

B) LIST OF FIXED MASSES:

NAME	DES	MASS t	LCG m	TCG m	VCG m
FIXED					
CREW	Mannskap og Proviant	2.0	4.00	0.00	9.60
STORE	Stores	2.0	1.00	0.00	8.00
ADDED	LETTSKIP ØKNING	83.0	28.37	0.00	5.39
SUBTOTAL		87.0	27.18	0.00	5.55

RELEVANT OPENINGS

NAME	X m	Y m	Z m	IMMA degree	IMMR m	REDPD m	OTYPE
O1	5.00	-2.500	11.800	-57.8	6.392	0.045	
O2	5.00	2.500	11.800	57.8	6.375	0.047	
O3	16.80	5.100	7.500	19.8	1.962	0.091	
O4	16.80	-5.100	7.500	-19.8	1.997	0.090	
O5	48.00	5.100	7.500	17.1	1.710	0.091	
O6	48.00	-5.100	7.500	-17.1	1.745	0.090	

LIST OF LOADED COMPARTMENTS

NAME	DES	MASS t	FILL %	LCG m	TCG m	VCG m	FRSM tm

CONTENTS=Solid cargo (RHO=0.817)							
C01	Fwd Cargohold	1048.6	100.0	45.22	0.00	4.58	0.0
C02	Aft Cargohold	1164.3	100.0	25.75	0.00	4.38	0.0

SUBTOTAL		2213.0	100.0	34.97	0.00	4.47	0.0
CONTENTS=FUEL OIL (RHO=0.86)							
02C	No.2 C Bunkers	104.5	96.0	36.60	0.00	0.68	172.2
03PC	No.3 PS-C Bunkers	31.5	98.0	21.08	-1.22	0.70	12.8
03SC	No.3 SB-C Bunkers	31.5	98.0	21.08	1.22	0.70	12.8
05P	No.5 PS Bunkers	20.5	98.0	10.04	-3.04	2.59	17.4
05S	No.5 SB Bunkers	28.4	95.0	11.16	3.21	2.56	28.1
08C	Daytank	8.5	95.0	14.75	0.00	5.48	12.9

SUBTOTAL		224.8	96.6	25.80	0.13	1.28	256.2
CONTENTS=FRESH WATER (RHO=1)							
06C	No.6 Aftpeak C FW	24.6	97.0	3.79	0.00	3.25	94.5
07C	No.7 Aft C Ballast	75.6	97.0	0.00	0.00	5.64	268.3

SUBTOTAL		100.2	97.0	0.93	0.00	5.05	362.8
CONTENTS=LUBRICATING OIL (RHO=0.92)							
08S	Lub. Oil	0.9	95.0	14.95	3.15	4.95	0.0
08P	Lub. Oil	0.9	95.0	14.95	-3.15	4.95	0.0

SUBTOTAL		1.8	95.0	14.95	0.00	4.95	0.0

Loading condition HL5

HEEL degree	GZ m	AREA rad*m	TR m	RESFLD m	RESFRB m
0.0	-0.008	0.000	0.518	1.74	-
0.4	0.000	0.000	0.518	1.71	-
1.0	0.013	0.000	0.518	1.66	-
3.0	0.060	0.001	0.517	1.48	-
5.0	0.109	0.004	0.515	1.30	-
10.0	0.210	0.019	0.546	0.82	-
20.0	0.231	0.058	0.665	-0.35	-
30.0	0.209	0.097	0.793	-1.61	-
40.0	0.137	0.128	0.919	-2.91	-
50.0	0.021	0.143	0.990	-4.22	-
60.0	-0.129	0.134	1.090	-5.48	-

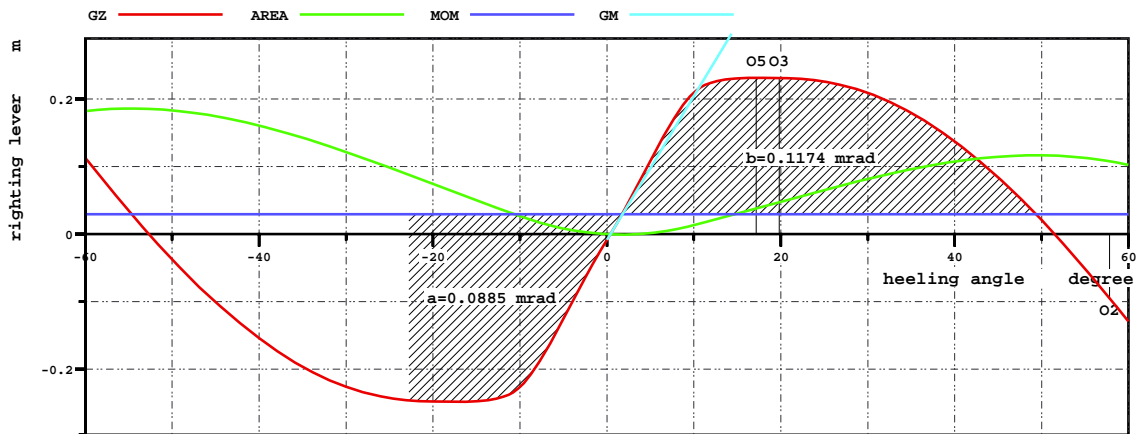

INTACT CRITERIA STATUS

RCR	TEXT	REQ	ATTV	MARGIN	UNIT	STAT
AREA30	GZ Area up to 30 deg.	0.055	0.097	0.042	mrاد	OK
AREA40	GZ Area up to 40 deg.	0.090	0.128	0.038	mrاد	OK
AREA3040	Minarea 30-40deg	0.030	0.031	0.001	mrاد	OK
GZ0.2	Max GZ > 0.2	0.200	0.209	0.009	m	OK
MAXGZ25	Max GZ at angle > 25deg	25.000	17.851	7.149	deg	NOT .
GM0.15	GM > 0.15 m	0.150	1.221	1.071	m	OK
IMOWEATHER	IMO weather crit.	1.000	1.328	0.328		OK

1.5 HL6 - Homogent lastet (5.625 m) - 10% Fo & Fv

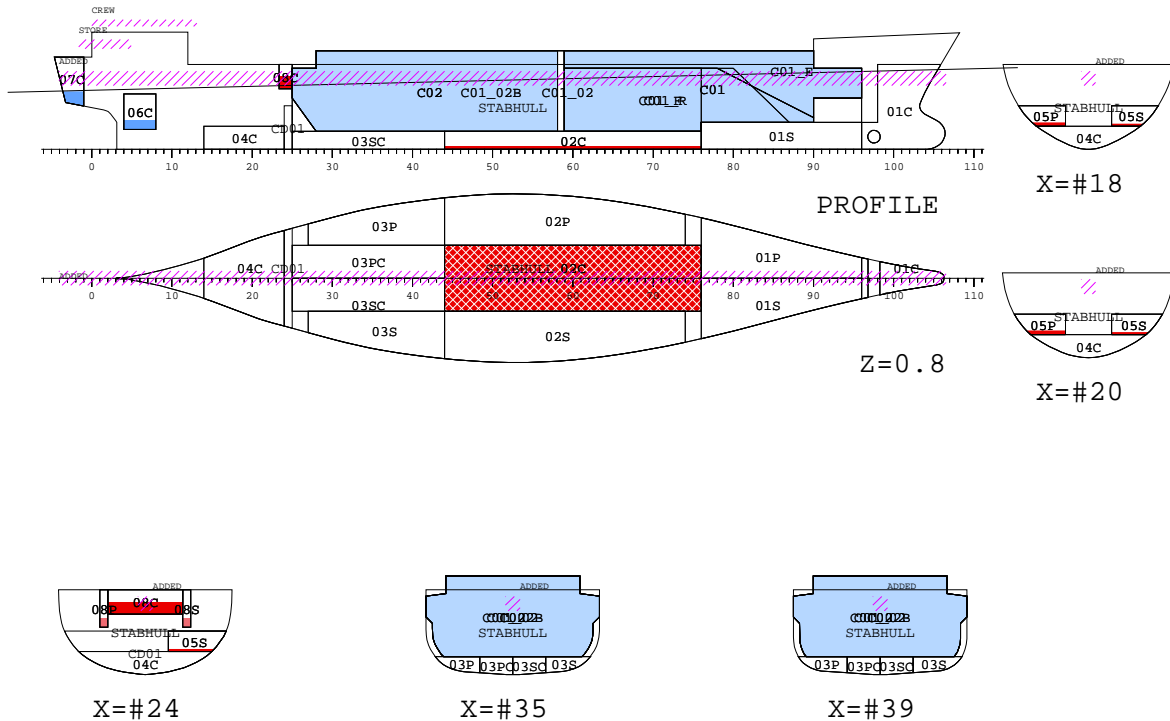

SEA WATER	Mean draught (moulded)	5.28 m
WATER BALLAST	Draught AP (moulded)	4.49 m
Solid cargo	Draught FP (moulded)	6.06 m
HYDRAULIC OIL	Draught Aft (below keel, x= 0.00 m)	4.50 m
LUBRICATING OIL	Draught Fore (below keel, x= 64.05 m)	6.07 m
FRESH WATER	Trim (by head)	1.57 m
FUEL OIL	Heeling	0.0 deg
	KM above the moulded base	5.89 m
	KG above the moulded base	4.72 m
	GM0 (solid)	1.17 m
	Free surface correction	0.08 m
	GM (fluid)	1.09 m
	Density of water	1.025 t/m3

	Weight t	LCG m	TCG m	VCG m
Lightweight	831.3	28.37	0.00	5.39
Deadweight	2334.2	34.44	0.00	4.48
Total weight	3165.5	32.84	0.00	4.72

DEADWEIGHT COMPONENTS

A) LIQUIDS:

NAME	LOAD	MASS t	FILL %	LCG m	TCG m	VCG m	FRSM tm
Solid cargo	CAS	2213.0	62.2	34.97	0.00	4.47	0.0
FUEL OIL	FO	23.4	10.1	25.69	0.00	1.51	203.1
FRESH WATER	FW	10.3	10.0	1.18	0.00	3.53	61.4
LUBRICATING OIL	LO	0.5	25.0	14.94	0.00	3.96	0.0
SEA WATER	SW	0.0	0.0	0.00	0.00	0.00	0.0
WATER BALLAST	WB	0.0	0.0	0.00	0.00	0.00	0.0
SUBTOTAL		2247.2	39.7	34.72	0.00	4.44	264.5

B) LIST OF FIXED MASSES:

NAME	DES	MASS t	LCG m	TCG m	VCG m
FIXED					
CREW	Mannskap og Proviant	2.0	4.00	0.00	9.60
STORE	Stores	2.0	1.00	0.00	8.00
ADDED	LETTSKIP ØKNING	83.0	28.37	0.00	5.39
SUBTOTAL		87.0	27.18	0.00	5.55

RELEVANT OPENINGS

NAME	X m	Y m	Z m	IMMA degree	IMMR m	REDPD m	OTYPE
O1	5.00	-2.500	11.800	-66.9	7.185	0.045	
O2	5.00	2.500	11.800	66.9	7.185	0.045	
O3	16.80	5.100	7.500	26.1	2.597	0.090	
O4	16.80	-5.100	7.500	-26.1	2.597	0.090	
O5	48.00	5.100	7.500	18.4	1.833	0.090	
O6	48.00	-5.100	7.500	-18.4	1.833	0.090	

LIST OF LOADED COMPARTMENTS

NAME	DES	MASS t	FILL %	LCG m	TCG m	VCG m	FRSM tm

CONTENTS=Solid cargo (RHO=0.817)							
C01	Fwd Cargohold	1048.6	100.0	45.22	0.00	4.58	0.0
C02	Aft Cargohold	1164.3	100.0	25.75	0.00	4.38	0.0

SUBTOTAL		2213.0	100.0	34.97	0.00	4.47	0.0
CONTENTS=FUEL OIL (RHO=0.86)							
02C	No.2 C Bunkers	12.8	11.8	36.60	0.00	0.12	172.2
05P	No.5 PS Bunkers	3.1	15.0	10.23	-2.71	1.88	6.5
05S	No.5 SB Bunkers	3.0	10.0	11.31	2.88	1.82	11.4
08C	Daytank	4.5	50.0	14.75	0.00	5.06	12.9

SUBTOTAL		23.4	13.9	25.69	0.00	1.51	203.1
CONTENTS=FRESH WATER (RHO=1)							
06C	No.6 Aftpeak C FW	2.5	10.0	3.91	0.00	1.90	2.0
07C	No.7 Aft C Ballast	7.8	10.0	0.29	0.00	4.06	59.4

SUBTOTAL		10.3	10.0	1.18	0.00	3.53	61.4
CONTENTS=LUBRICATING OIL (RHO=0.92)							
08S	Lub. Oil	0.2	25.0	14.94	3.15	3.96	0.0
08P	Lub. Oil	0.2	25.0	14.94	-3.15	3.96	0.0

SUBTOTAL		0.5	25.0	14.94	0.00	3.96	0.0

Loading condition HL6

HEEL degree	GZ m	AREA rad*m	TR m	RESFLD m	RESFRB m
0.0	0.000	0.000	1.570	1.83	-
1.0	0.019	0.000	1.570	1.74	-
3.0	0.057	0.001	1.568	1.57	-
5.0	0.097	0.004	1.565	1.39	-
10.0	0.192	0.017	1.578	0.92	-
20.0	0.255	0.058	1.789	-0.18	-
30.0	0.215	0.100	1.962	-1.41	-
40.0	0.134	0.131	2.255	-2.71	-
50.0	-0.005	0.144	2.536	-4.02	-
60.0	-0.198	0.126	2.806	-5.27	-

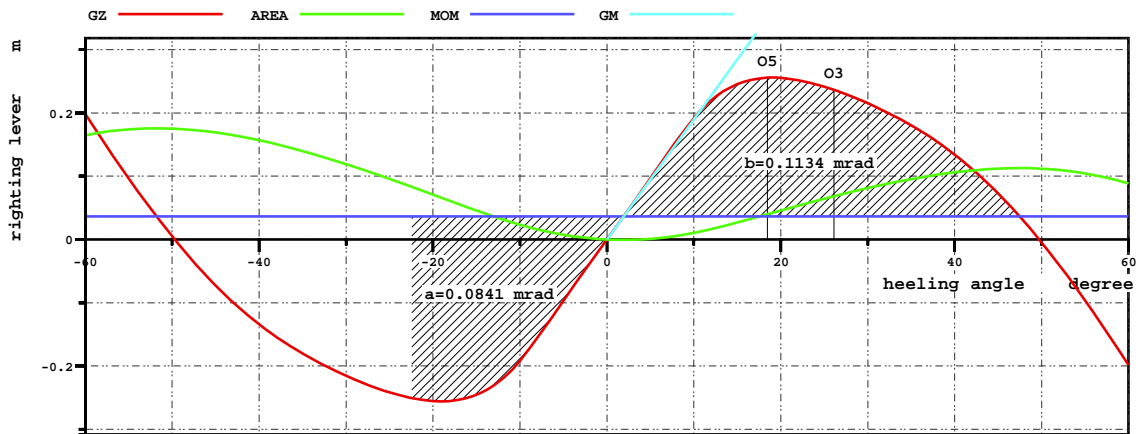





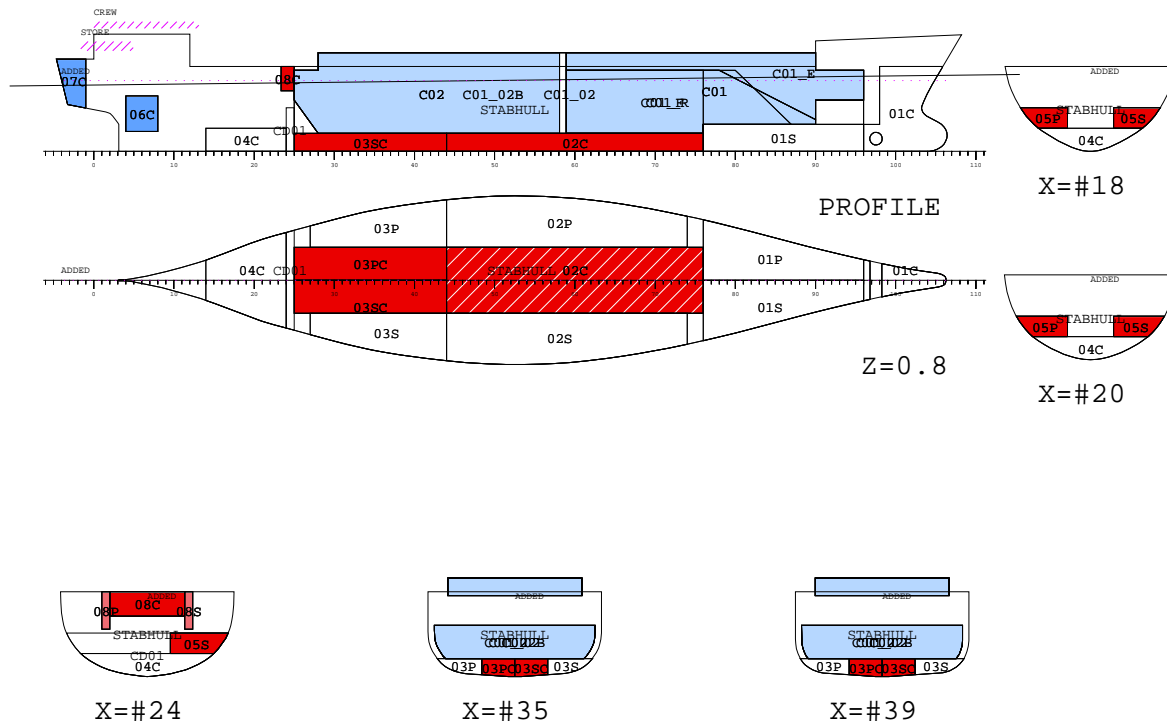

INTACT CRITERIA STATUS

RCR	TEXT	REQ	ATTV	MARGIN	UNIT	STAT
AREA30	GZ Area up to 30 deg.	0.055	0.100	0.045	mrad	OK
AREA40	GZ Area up to 40 deg.	0.090	0.131	0.041	mrad	OK
AREA3040	Minarea 30-40deg	0.030	0.031	0.001	mrad	OK
GZ0.2	Max GZ > 0.2	0.200	0.215	0.015	m	OK
MAXGZ25	Max GZ at angle > 25deg	25.000	19.018	5.982	deg	NOT .
GM0.15	GM > 0.15 m	0.150	1.088	0.938	m	OK
IMOWEATHER	IMO weather crit.	1.000	1.348	0.348		OK

1.6 HL1_UA - Homogent lastet til 5.40 m - 100% Fo & Fv



	SEA WATER
	WATER BALLAST
	Solid cargo
	HYDRAULIC OIL
	LUBRICATING OIL
	FRESH WATER
	FUEL OIL

Mean draught (moulded)	5.40 m
Draught AP (moulded)	5.04 m
Draught FP (moulded)	5.76 m
Draught Aft (below keel, x= 0.00 m)	5.05 m
Draught Fore (below keel, x= 64.05 m)	5.77 m
Trim (by head)	0.72 m
Heeling to starboard side	0.4 deg
KM above the moulded base	5.90 m
KG above the moulded base	4.51 m
GM0 (solid)	1.39 m
Free surface correction	0.19 m
GM (fluid)	1.20 m
Density of water	1.025 t/m3

	Weight t	LCG m	TCG m	VCG m
Lightweight	831.3	29.64	0.00	5.39
Deadweight	2446.3	32.67	0.01	4.21
Total weight	3277.6	31.90	0.01	4.51

DEADWEIGHT COMPONENTS

A) LIQUIDS:

NAME	LOAD	MASS t	FILL %	LCG m	TCG m	VCG m	FRSM tm
Solid cargo	CAS	2115.4	62.2	34.97	0.00	4.47	0.0
FUEL OIL	FO	224.8	96.6	25.80	0.13	1.28	256.2
FRESH WATER	FW	100.2	97.0	0.93	0.00	5.05	362.8
LUBRICATING OIL	LO	1.8	95.0	14.94	0.00	4.95	0.0
SEA WATER	SW	0.0	0.0	0.00	0.00	0.00	0.0
WATER BALLAST	WB	0.0	0.0	0.00	0.00	0.00	0.0
SUBTOTAL		2442.3	39.3	32.72	0.01	4.20	619.0

B) LIST OF FIXED MASSES:

NAME	DES	MASS t	LCG m	TCG m	VCG m
FIXED					
CREW	Mannskap og Proviant	2.0	4.00	0.00	9.60
STORE	Stores	2.0	1.00	0.00	8.00
SUBTOTAL		4.0	2.50	0.00	8.80

RELEVANT OPENINGS

NAME	X m	Y m	Z m	IMMA degree	IMMR m	REDPD m	OTYPE
O1	5.00	-2.500	11.800	-61.5	6.705	0.045	
O2	5.00	2.500	11.800	61.5	6.687	0.047	
O3	16.80	5.100	7.500	22.8	2.235	0.091	
O4	16.80	-5.100	7.500	-22.8	2.273	0.090	
O5	48.00	5.100	7.500	19.2	1.884	0.091	
O6	48.00	-5.100	7.500	-19.2	1.921	0.090	

LIST OF LOADED COMPARTMENTS

NAME	DES	MASS t	FILL %	LCG m	TCG m	VCG m	FRSM tm

CONTENTS=Solid cargo (RHO=0.781)							
C01	Fwd Cargohold	1002.4	100.0	45.22	0.00	4.58	0.0
C02	Aft Cargohold	1113.0	100.0	25.75	0.00	4.38	0.0

SUBTOTAL		2115.4	100.0	34.97	0.00	4.47	0.0
CONTENTS=FUEL OIL (RHO=0.86)							
02C	No.2 C Bunkers	104.5	96.0	36.60	0.00	0.68	172.2
03PC	No.3 PS-C Bunkers	31.5	98.0	21.08	-1.22	0.70	12.8
03SC	No.3 SB-C Bunkers	31.5	98.0	21.08	1.22	0.70	12.8
05P	No.5 PS Bunkers	20.5	98.0	10.04	-3.04	2.59	17.4
05S	No.5 SB Bunkers	28.4	95.0	11.16	3.21	2.56	28.1
08C	Daytank	8.5	95.0	14.75	-0.00	5.48	12.9

SUBTOTAL		224.8	96.6	25.80	0.13	1.28	256.2
CONTENTS=FRESH WATER (RHO=1)							
06C	No.6 Aftpeak C FW	24.6	97.0	3.79	0.00	3.25	94.5
07C	No.7 Aft C Ballast	75.6	97.0	-0.00	0.00	5.64	268.3

SUBTOTAL		100.2	97.0	0.93	0.00	5.05	362.8
CONTENTS=LUBRICATING OIL (RHO=0.92)							
08S	Lub. Oil	0.9	95.0	14.94	3.14	4.95	0.0
08P	Lub. Oil	0.9	95.0	14.94	-3.14	4.95	0.0

SUBTOTAL		1.8	95.0	14.94	0.00	4.95	0.0

Loading condition HL1_UA

HEEL degree	GZ m	AREA rad*m	TR m	RESFLD m	RESFRB m
0.0	-0.009	0.000	0.721	1.92	-
0.4	-0.000	-0.000	0.721	1.88	-
1.0	0.012	0.000	0.721	1.83	-
3.0	0.058	0.001	0.721	1.65	-
5.0	0.107	0.004	0.720	1.47	-
10.0	0.227	0.019	0.726	1.02	-
20.0	0.300	0.068	0.866	-0.10	-
30.0	0.293	0.120	1.003	-1.33	-
40.0	0.239	0.167	1.190	-2.63	-
50.0	0.124	0.200	1.322	-3.92	-
60.0	-0.039	0.207	1.438	-5.14	-

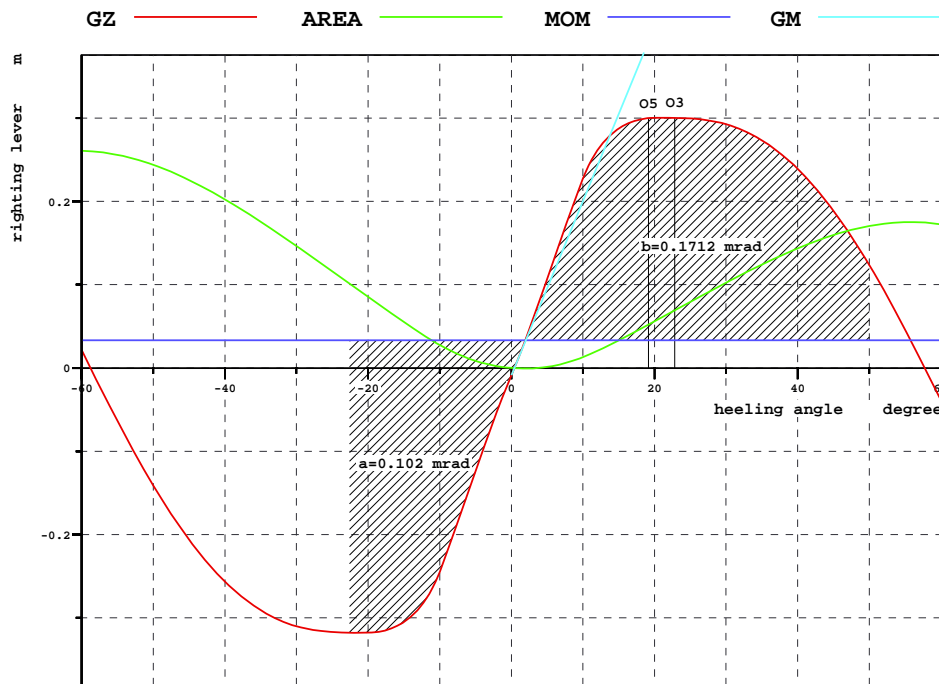

INTACT CRITERIA STATUS

RCR	TEXT	REQ	ATTV	MARGIN	UNIT	STAT
AREA30	GZ Area up to 30 deg.	0.055	0.120	0.065	mrad	OK
AREA40	GZ Area up to 40 deg.	0.090	0.167	0.077	mrad	OK
AREA3040	Minarea 30-40deg	0.030	0.047	0.017	mrad	OK
GZ0.2	Max GZ > 0.2	0.200	0.293	0.093	m	OK
MAXGZ25	Max GZ at angle > 25deg	25.000	21.250	3.750	deg	NOT .
GM0.15	GM > 0.15 m	0.150	1.198	1.048	m	OK
IMOWEATHER	IMO weather crit.	1.000	1.679	0.679		OK

1.7 HL2_UA - Homogent lastet (5.40 m) - 10% Fo & Fv

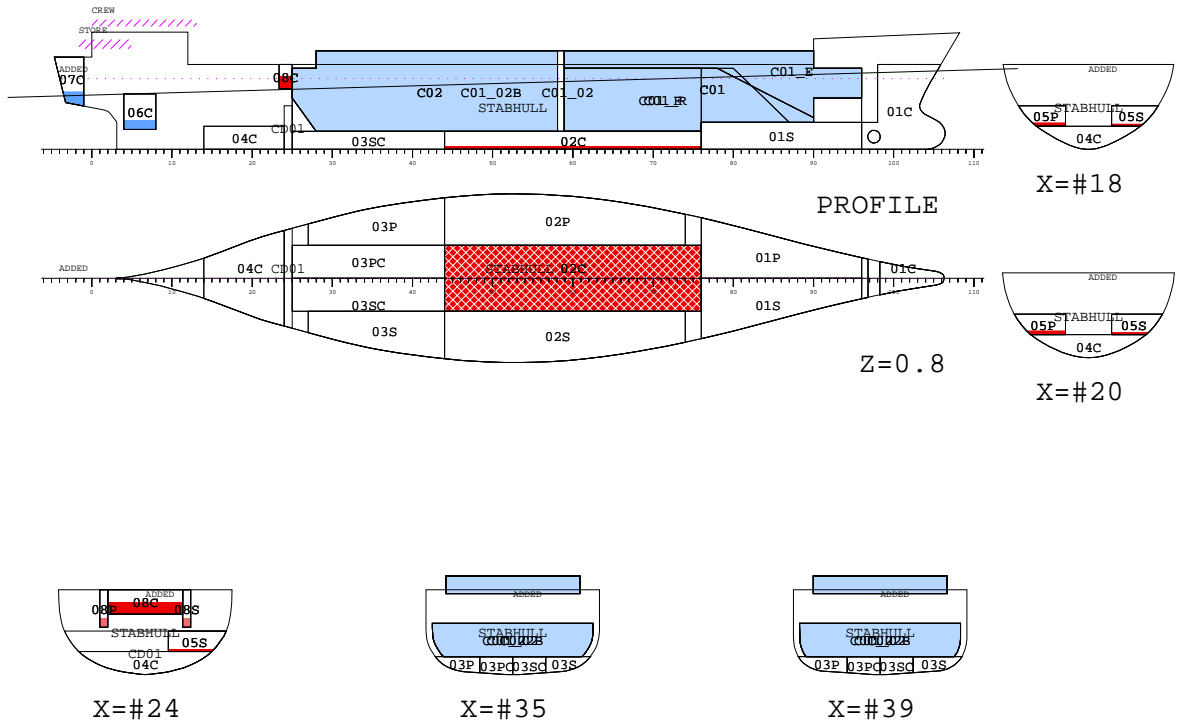

SEA WATER
WATER BALLAST
Solid cargo
HYDRAULIC OIL
LUBRICATING OIL
FRESH WATER
FUEL OIL

Mean draught (moulded)	5.04 m
Draught AP (moulded)	4.13 m
Draught FP (moulded)	5.96 m
Draught Aft (below keel, x= 0.00 m)	4.14 m
Draught Fore (below keel, x= 64.05 m)	5.97 m
Trim (by head)	1.83 m
Heeling	0.0 deg
KM above the moulded base	5.87 m
KG above the moulded base	4.71 m
GM0 (solid)	1.16 m
Free surface correction	0.09 m
GM (fluid)	1.07 m
Density of water	1.025 t/m3

	Weight t	LCG m	TCG m	VCG m
Lightweight	831.3	29.64	0.00	5.39
Deadweight	2153.7	34.65	0.00	4.45
Total weight	2985.0	33.25	0.00	4.71

DEADWEIGHT COMPONENTS

A) LIQUIDS:

NAME	LOAD	MASS t	FILL %	LCG m	TCG m	VCG m	FRSM tm
Solid cargo	CAS	2115.4	62.2	34.97	0.00	4.47	0.0
FUEL OIL	FO	23.4	10.1	25.69	0.00	1.51	203.1
FRESH WATER	FW	10.3	10.0	1.18	0.00	3.53	61.4
LUBRICATING OIL	LO	0.5	25.0	14.94	0.00	3.96	0.0
SEA WATER	SW	0.0	0.0	0.00	0.00	0.00	0.0
WATER BALLAST	WB	0.0	0.0	0.00	0.00	0.00	0.0
SUBTOTAL		2149.7	35.1	34.71	0.00	4.44	264.5

B) LIST OF FIXED MASSES:

NAME	DES	MASS t	LCG m	TCG m	VCG m
FIXED					
CREW	Mannskap og Proviant	2.0	4.00	0.00	9.60
STORE	Stores	2.0	1.00	0.00	8.00
SUBTOTAL		4.0	2.50	0.00	8.80

RELEVANT OPENINGS

NAME	X m	Y m	Z m	IMMA degree	IMMR m	REDPD m	OTYPE
01	5.00	-2.500	11.800	-70.6	7.529	0.045	
02	5.00	2.500	11.800	70.6	7.529	0.045	
03	16.80	5.100	7.500	29.2	2.893	0.090	
04	16.80	-5.100	7.500	-29.2	2.893	0.090	
05	48.00	5.100	7.500	20.3	2.002	0.090	
06	48.00	-5.100	7.500	-20.3	2.002	0.090	

LIST OF LOADED COMPARTMENTS

NAME	DES	MASS t	FILL %	LCG m	TCG m	VCG m	FRSM tm

CONTENTS=Solid cargo (RHO=0.781)							
C01	Fwd Cargohold	1002.4	100.0	45.22	0.00	4.58	0.0
C02	Aft Cargohold	1113.0	100.0	25.75	0.00	4.38	0.0

SUBTOTAL		2115.4	100.0	34.97	0.00	4.47	0.0

CONTENTS=FUEL OIL (RHO=0.86)							
02C	No.2 C Bunkers	12.8	11.8	36.60	0.00	0.12	172.2
05P	No.5 PS Bunkers	3.1	15.0	10.23	-2.71	1.88	6.5
05S	No.5 SB Bunkers	3.0	10.0	11.31	2.88	1.82	11.4
08C	Daytank	4.5	50.0	14.75	0.00	5.06	12.9

SUBTOTAL		23.4	13.9	25.69	0.00	1.51	203.1

CONTENTS=FRESH WATER (RHO=1)							
06C	No.6 Aftpeak C FW	2.5	10.0	3.91	0.00	1.90	2.0
07C	No.7 Aft C Ballast	7.8	10.0	0.29	0.00	4.06	59.4

SUBTOTAL		10.3	10.0	1.18	0.00	3.53	61.4

CONTENTS=LUBRICATING OIL (RHO=0.92)							
08S	Lub. Oil	0.2	25.0	14.94	3.14	3.96	0.0
08P	Lub. Oil	0.2	25.0	14.94	-3.14	3.96	0.0

SUBTOTAL		0.5	25.0	14.94	0.00	3.96	0.0

Loading condition HL2_UA

HEEL degree	GZ m	AREA rad*m	TR m	RESFLD m	RESFRB m
0.0	0.000	0.000	1.832	2.00	-
1.0	0.019	0.000	1.831	1.91	-
3.0	0.056	0.001	1.830	1.73	-
5.0	0.095	0.004	1.827	1.55	-
10.0	0.196	0.017	1.820	1.10	-
20.0	0.308	0.063	2.011	0.04	-
30.0	0.294	0.117	2.187	-1.16	-
40.0	0.221	0.162	2.467	-2.43	-
50.0	0.083	0.190	2.779	-3.71	-
60.0	-0.122	0.187	3.064	-4.93	-

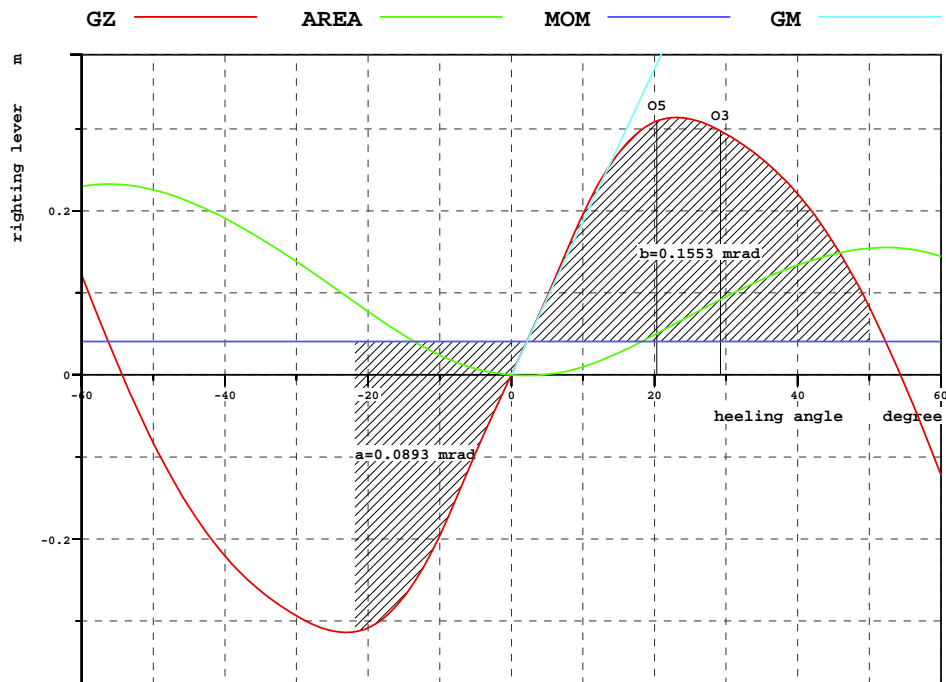





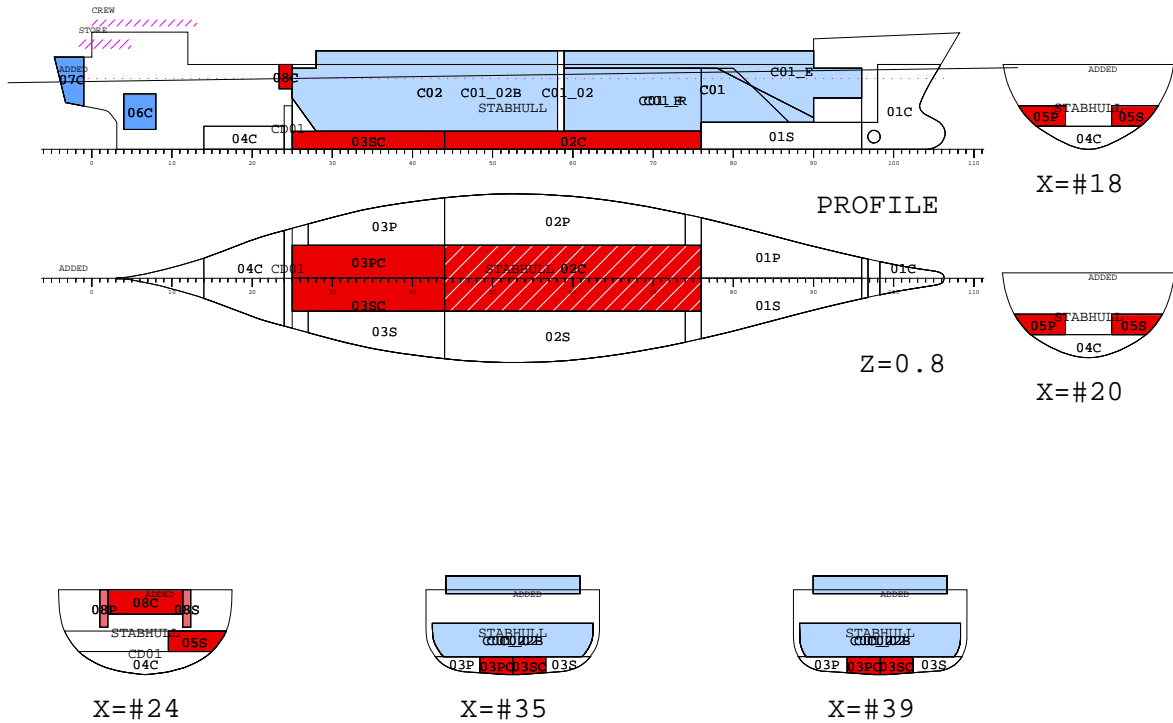

INTACT CRITERIA STATUS

RCR	TEXT	REQ	ATTV	MARGIN	UNIT	STAT
AREA30	GZ Area up to 30 deg.	0.055	0.117	0.062	mrad	OK
AREA40	GZ Area up to 40 deg.	0.090	0.162	0.072	mrad	OK
AREA3040	Minarea 30-40deg	0.030	0.046	0.016	mrad	OK
GZ0.2	Max GZ > 0.2	0.200	0.294	0.094	m	OK
MAXGZ25	Max GZ at angle > 25deg	25.000	23.039	1.961	deg	NOT .
GM0.15	GM > 0.15 m	0.150	1.069	0.919	m	OK
IMOWEATHER	IMO weather crit.	1.000	1.739	0.739		OK

1.8 HL5_UA - Homogent lastet 5.625 m - 100% Fo & Fv



	SEA WATER
	WATER BALLAST
	Solid cargo
	HYDRAULIC OIL
	LUBRICATING OIL
	FRESH WATER
	FUEL OIL

Mean draught (moulded)	5.63 m
Draught AP (moulded)	5.14 m
Draught FP (moulded)	6.11 m
Draught Aft (below keel, x= 0.00 m)	5.15 m
Draught Fore (below keel, x= 64.05 m)	6.12 m
Trim (by head)	0.96 m
Heeling to starboard side	0.4 deg
KM above the moulded base	5.94 m
KG above the moulded base	4.51 m
GM0 (solid)	1.43 m
Free surface correction	0.18 m
GM (fluid)	1.25 m
Density of water	1.025 t/m3

	Weight t	LCG m	TCG m	VCG m
Lightweight	831.3	29.64	0.00	5.39
Deadweight	2616.9	32.82	0.01	4.23
Total weight	3448.2	32.05	0.01	4.51

DEADWEIGHT COMPONENTS

A) LIQUIDS:

NAME	LOAD	MASS t	FILL %	LCG m	TCG m	VCG m	FRSM tm
Solid cargo	CAS	2286.1	62.2	34.97	0.00	4.47	0.0
FUEL OIL	FO	224.8	96.6	25.80	0.13	1.28	256.2
FRESH WATER	FW	100.2	97.0	0.93	0.00	5.05	362.8
LUBRICATING OIL	LO	1.8	95.0	14.94	0.00	4.95	0.0
SEA WATER	SW	0.0	0.0	0.00	0.00	0.00	0.0
WATER BALLAST	WB	0.0	0.0	0.00	0.00	0.00	0.0
SUBTOTAL		2612.9	39.3	32.86	0.01	4.22	619.0

B) LIST OF FIXED MASSES:

NAME	DES	MASS t	LCG m	TCG m	VCG m
FIXED					
CREW	Mannskap og Proviant	2.0	4.00	0.00	9.60
STORE	Stores	2.0	1.00	0.00	8.00
SUBTOTAL		4.0	2.50	0.00	8.80

RELEVANT OPENINGS

NAME	X m	Y m	Z m	IMMA degree	IMMR m	REDPD m	OTYPE
O1	5.00	-2.500	11.800	-60.0	6.579	0.045	
O2	5.00	2.500	11.800	60.0	6.562	0.047	
O3	16.80	5.100	7.500	20.8	2.068	0.091	
O4	16.80	-5.100	7.500	-20.8	2.102	0.090	
O5	48.00	5.100	7.500	16.0	1.598	0.091	
O6	48.00	-5.100	7.500	-16.0	1.632	0.090	

LIST OF LOADED COMPARTMENTS

NAME	DES	MASS t	FILL %	LCG m	TCG m	VCG m	FRSM tm

CONTENTS=Solid cargo (RHO=0.844)							
C01	Fwd Cargohold	1083.3	100.0	45.22	0.00	4.58	0.0
C02	Aft Cargohold	1202.8	100.0	25.75	0.00	4.38	0.0

SUBTOTAL		2286.1	100.0	34.97	0.00	4.47	0.0
CONTENTS=FUEL OIL (RHO=0.86)							
02C	No.2 C Bunkers	104.5	96.0	36.60	0.00	0.68	172.2
03PC	No.3 PS-C Bunkers	31.5	98.0	21.08	-1.22	0.70	12.8
03SC	No.3 SB-C Bunkers	31.5	98.0	21.08	1.22	0.70	12.8
05P	No.5 PS Bunkers	20.5	98.0	10.04	-3.04	2.59	17.4
05S	No.5 SB Bunkers	28.4	95.0	11.16	3.21	2.56	28.1
08C	Daytank	8.5	95.0	14.75	-0.00	5.48	12.9

SUBTOTAL		224.8	96.6	25.80	0.13	1.28	256.2
CONTENTS=FRESH WATER (RHO=1)							
06C	No.6 Aftpeak C FW	24.6	97.0	3.79	0.00	3.25	94.5
07C	No.7 Aft C Ballast	75.6	97.0	-0.00	0.00	5.64	268.3

SUBTOTAL		100.2	97.0	0.93	0.00	5.05	362.8
CONTENTS=LUBRICATING OIL (RHO=0.92)							
08S	Lub. Oil	0.9	95.0	14.94	3.14	4.95	0.0
08P	Lub. Oil	0.9	95.0	14.94	-3.14	4.95	0.0

SUBTOTAL		1.8	95.0	14.94	0.00	4.95	0.0

Loading condition HL5_UA

HEEL degree	GZ m	AREA rad*m	TR m	RESFLD m	RESFRB m
0.0	-0.008	0.000	0.965	1.63	-
0.4	-0.000	-0.000	0.965	1.60	-
1.0	0.014	0.000	0.965	1.54	-
3.0	0.061	0.001	0.963	1.36	-
5.0	0.111	0.004	0.960	1.19	-
10.0	0.208	0.019	1.022	0.69	-
20.0	0.238	0.059	1.185	-0.48	-
30.0	0.217	0.099	1.353	-1.75	-
40.0	0.150	0.132	1.566	-3.08	-
50.0	0.037	0.149	1.739	-4.42	-
60.0	-0.112	0.143	1.932	-5.69	-

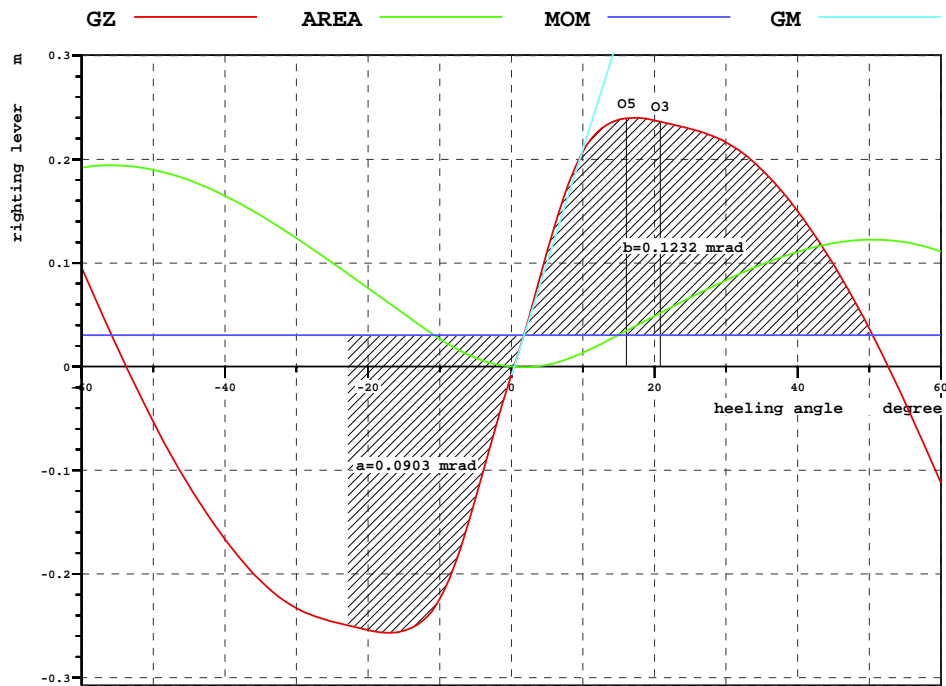

INTACT CRITERIA STATUS

RCR	TEXT	REQ	ATTV	MARGIN	UNIT	STAT
AREA30	GZ Area up to 30 deg.	0.055	0.099	0.044	mrad	OK
AREA40	GZ Area up to 40 deg.	0.090	0.132	0.042	mrad	OK
AREA3040	Minarea 30-40deg	0.030	0.033	0.003	mrad	OK
GZ0.2	Max GZ > 0.2	0.200	0.217	0.017	m	OK
MAXGZ25	Max GZ at angle > 25deg	25.000	17.132	7.868	deg	NOT .
GM0.15	GM > 0.15 m	0.150	1.248	1.098	m	OK
IMOWEATHER	IMO weather crit.	1.000	1.364	0.364		OK

1.9 HL6_UA - Homogent lastet (5.625 m) - 10% Fo & Fv

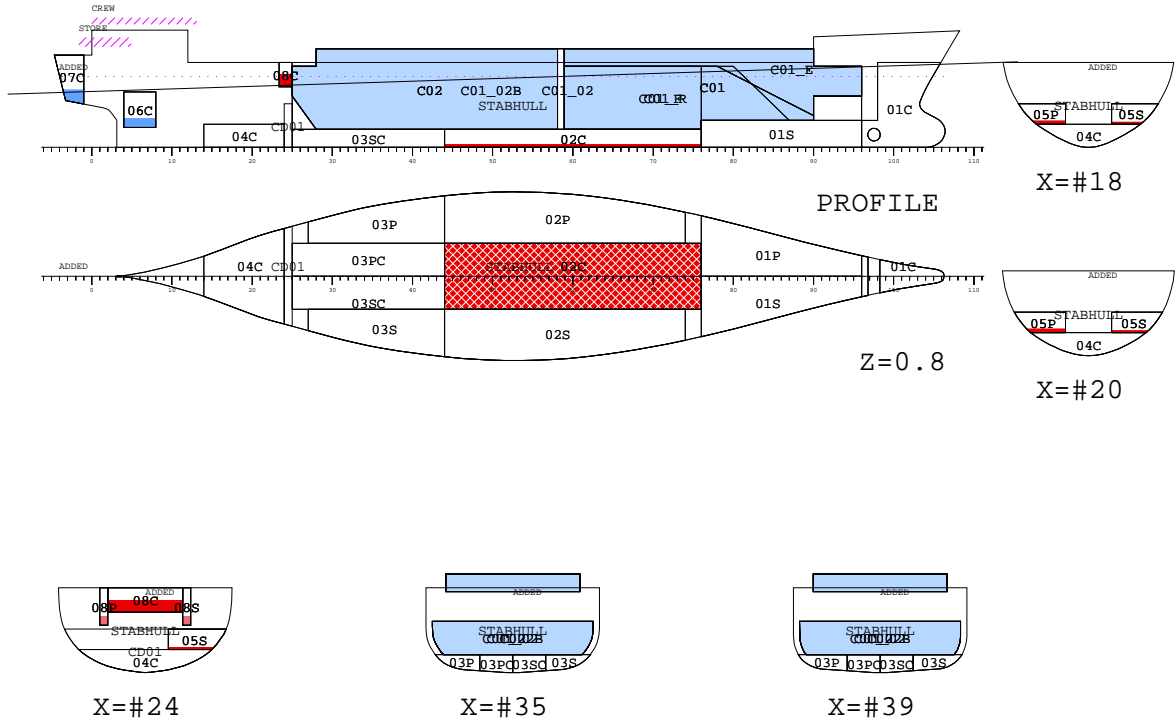

SEA WATER
WATER BALLAST
Solid cargo
HYDRAULIC OIL
LUBRICATING OIL
FRESH WATER
FUEL OIL

Mean draught (moulded)	5.27 m
Draught AP (moulded)	4.25 m
Draught FP (moulded)	6.29 m
Draught Aft (below keel, x= 0.00 m)	4.26 m
Draught Fore (below keel, x= 64.05 m)	6.30 m
Trim (by head)	2.05 m
Heeling	0.0 deg
KM above the moulded base	5.90 m
KG above the moulded base	4.70 m
GM0 (solid)	1.21 m
Free surface correction	0.08 m
GM (fluid)	1.12 m
Density of water	1.025 t/m3

	Weight t	LCG m	TCG m	VCG m
Lightweight	831.3	29.64	0.00	5.39
Deadweight	2324.3	34.67	0.00	4.45
Total weight	3155.6	33.35	0.00	4.70

DEADWEIGHT COMPONENTS

A) LIQUIDS:

NAME	LOAD	MASS t	FILL %	LCG m	TCG m	VCG m	FRSM tm
Solid cargo	CAS	2286.1	62.2	34.97	0.00	4.47	0.0
FUEL OIL	FO	23.4	10.1	25.69	0.00	1.51	203.1
FRESH WATER	FW	10.3	10.0	1.18	0.00	3.53	61.4
LUBRICATING OIL	LO	0.5	25.0	14.94	0.00	3.96	0.0
SEA WATER	SW	0.0	0.0	0.00	0.00	0.00	0.0
WATER BALLAST	WB	0.0	0.0	0.00	0.00	0.00	0.0
SUBTOTAL		2320.3	35.1	34.73	0.00	4.44	264.5

B) LIST OF FIXED MASSES:

NAME	DES	MASS t	LCG m	TCG m	VCG m
FIXED					
CREW	Mannskap og Proviant	2.0	4.00	0.00	9.60
STORE	Stores	2.0	1.00	0.00	8.00
SUBTOTAL		4.0	2.50	0.00	8.80

RELEVANT OPENINGS

NAME	X m	Y m	Z m	IMMA degree	IMMR m	REDPD m	OTYPE
O1	5.00	-2.500	11.800	-69.2	7.388	0.045	
O2	5.00	2.500	11.800	69.2	7.388	0.045	
O3	16.80	5.100	7.500	27.2	2.714	0.090	
O4	16.80	-5.100	7.500	-27.2	2.714	0.090	
O5	48.00	5.100	7.500	17.3	1.717	0.090	
O6	48.00	-5.100	7.500	-17.3	1.717	0.090	

LIST OF LOADED COMPARTMENTS

NAME	DES	MASS t	FILL %	LCG m	TCG m	VCG m	FRSM tm

CONTENTS=Solid cargo (RHO=0.844)							
C01	Fwd Cargohold	1083.3	100.0	45.22	0.00	4.58	0.0
C02	Aft Cargohold	1202.8	100.0	25.75	0.00	4.38	0.0

SUBTOTAL		2286.1	100.0	34.97	0.00	4.47	0.0

CONTENTS=FUEL OIL (RHO=0.86)							
02C	No.2 C Bunkers	12.8	11.8	36.60	0.00	0.12	172.2
05P	No.5 PS Bunkers	3.1	15.0	10.23	-2.71	1.88	6.5
05S	No.5 SB Bunkers	3.0	10.0	11.31	2.88	1.82	11.4
08C	Daytank	4.5	50.0	14.75	0.00	5.06	12.9

SUBTOTAL		23.4	13.9	25.69	0.00	1.51	203.1

CONTENTS=FRESH WATER (RHO=1)							
06C	No.6 Aftpeak C FW	2.5	10.0	3.91	0.00	1.90	2.0
07C	No.7 Aft C Ballast	7.8	10.0	0.29	0.00	4.06	59.4

SUBTOTAL		10.3	10.0	1.18	0.00	3.53	61.4

CONTENTS=LUBRICATING OIL (RHO=0.92)							
08S	Lub. Oil	0.2	25.0	14.94	3.14	3.96	0.0
08P	Lub. Oil	0.2	25.0	14.94	-3.14	3.96	0.0

SUBTOTAL		0.5	25.0	14.94	0.00	3.96	0.0

Loading condition HL6_UA

HEEL degree	GZ m	AREA rad*m	TR m	RESFLD m	RESFRB m
0.0	0.000	0.000	2.046	1.72	-
1.0	0.020	0.000	2.046	1.63	-
3.0	0.059	0.002	2.044	1.45	-
5.0	0.100	0.004	2.039	1.27	-
10.0	0.189	0.017	2.074	0.80	-
20.0	0.258	0.058	2.318	-0.32	-
30.0	0.220	0.101	2.519	-1.55	-
40.0	0.138	0.133	2.855	-2.87	-
50.0	0.003	0.146	3.241	-4.21	-
60.0	-0.187	0.131	3.599	-5.48	-

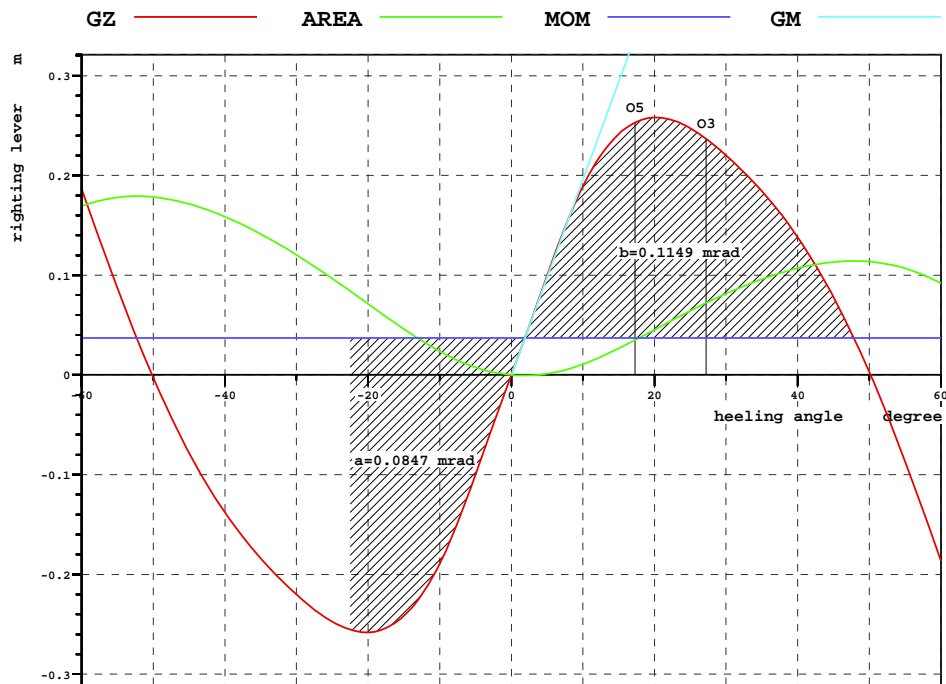

INTACT CRITERIA STATUS

RCR	TEXT	REQ	ATTV	MARGIN	UNIT	STAT
AREA30	GZ Area up to 30 deg.	0.055	0.101	0.046	mrad	OK
AREA40	GZ Area up to 40 deg.	0.090	0.133	0.043	mrad	OK
AREA3040	Minarea 30-40deg	0.030	0.032	0.002	mrad	OK
GZ0.2	Max GZ > 0.2	0.200	0.220	0.020	m	OK
MAXGZ25	Max GZ at angle > 25deg	25.000	20.192	4.808	deg	NOT .
GM0.15	GM > 0.15 m	0.150	1.122	0.972	m	OK
IMOWEATHER	IMO weather crit.	1.000	1.357	0.357		OK

VEDLEGG K

REFERANSER

Bye, R. & Lamvik, G. M. (2007). Professional culture and risk perception: Coping with danger on board small fishing boats and offshore service vessels. *Reliability Engineering and System Safety*, 92: 1756-1763.

Lamvik, G. M, Wahl, A. M. & Buvik, M. P. (2010). Professional culture, work practice and reliable operations in shipping. *I Reliability, Risk and Safety: Theory and Applications*. Bris, Guedes Soares & Martorell (red.) London: Taylor & Francis Group.